



---

2025/2026 General Catalog



## The Company

### We make confidence:

RAAD offers confidence to its clientele, and this is not treated as a single slogan but as our aim and belief. Over 40 years of experience and endeavor have helped us to design, expand, produce, and vend a vast range of products, from terminal blocks to circuit protection equipment, and from wiring ducts and Din rails to other components for electrical connection technology, and thus meeting our customers' needs quite properly.

### Product approvals create trust:

Raad's products' quality certificates are the proof of high quality of these products. RAAD Products have attained certificates from institutions like VDE, DEKRA (KEMA), and FTZU guaranteeing the products compatibility with international standards, and are suitable for potentially explosive atmospheres (ATEX Directive).

### RAAD global market:

Replying to clientele's needs as well as supporting them is one of our commitments. RAAD as the pioneer and leading producer in the Iranian domestic market and the Middle East, and thanks to his 40 representatives and sales agents, has had efficient exports to global markets as well.

**RAAD Manufacturing Co.** reserves the right to make changes to any information given in this catalog regarding technical progress.

**Please contact us for update technical information and new prices.**

#### Factory

20th Ave., Azadegan Rd. Isfahan - Iran  
P.O. Box 81395/111  
Tel.: +98 31 3 3802026  
Fax: +98 31 33802013  
info@raadmail.com  
sales@raadmail.com  
www.raadconnections.ir

# Contents

## Modular Terminal Blocks

### ■ Universal Terminal Blocks

Page 19



RT/SU2.5 (RTP2.5)  
Page 20



RT/SU2.5-H (RTP2.5-H)  
Page 20



RT/SU4 (RTP4)  
Page 21



RT/SU6 (RTP6)  
Page 21



RT/SU10 (RTP10)  
Page 22



RT/SU16 (RTP16)  
Page 22



RT/SU25 (RTP25)  
Page 23



RT/SU35 (RTP35)  
Page 23



RT/SU50 (RTP50)  
Page 24



RT/SU70 (RTP70)  
Page 24



RT/SU95 (RTP95)  
Page 25



RT/SU150 (RTP150)  
Page 25

Protective Conductor Terminal Blocks

Page 27



RT/SU2.5-E (RET2.5)  
Page 26



RT/SU4-E (RET4)  
Page 26

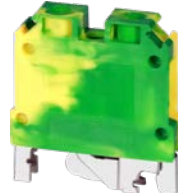

RT/SU6-E (RET6)  
Page 27



RT/SU10-E (RET10)  
Page 27



RT/SU16-E (RET16)  
Page 28



RT/SU35-E (RET35)  
Page 28



RT/SU2.5-SO (RETN2.5)  
Page 29



RT/SU4-SO (RETN4)  
Page 29



RT/SU6-SO (RETN6)  
Page 30



RT/SU10-SO (RETN10)  
Page 30

Multi Level Terminal Blocks

Page 35



RT/SU2.5/4-2L (DRTP2.5/4)  
Page 37



RT/SU2.5/4-2L-L (DRTP2.5/4-L)  
Page 35



RT/SU4-2L (DRTP4)  
Page 38



RT/SU4-3L (TRTP4)  
Page 36



RT/SU10-2L  
Page 37



RT/SU2.5-3LOE5  
Page 37

Test Disconnect Terminal Blocks

Page 41

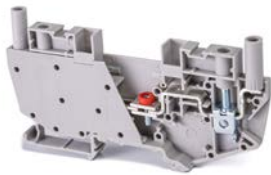

**RT/ST6 (RST6)**  
Page 42

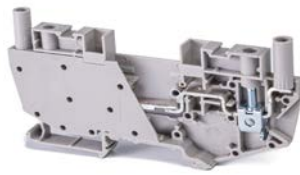

**RT/ST6-L (RTT6)**  
Page 42

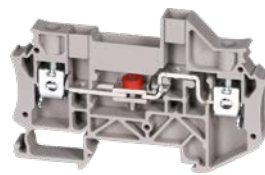

**RT/ST6-SHT (RSTT6)**  
Page 41

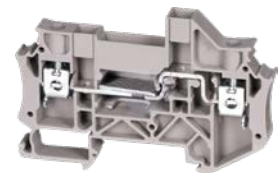

**RT/ST6-SHT-L (RSTU6)**  
Page 41



**RSTP6**  
Page 42



**RT/ST6-CMP (RSTN6)**  
Page 42

Disconnect and Component Terminal Blocks

Page 47



**RT/SK2.5 (RDT2.5-C)**  
Page 46



**RT/SK2.5-TS (RDT2.5-CTS)**  
Page 46



**RT/SK2.5-D (RDT2.5-CDC)**  
Page 47



**RT/SK2.5-R (RDT2.5-CRC)**  
Page 47

■ Fuse Terminal Blocks

Page 51

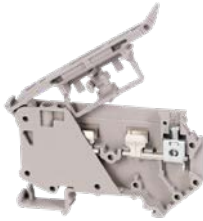

RT/SF4 (RFT5)  
Page 52



RT/SF4-LD (RFT5-LD)  
Page 50



RT/SK2.5-F (RDT2.5-CFC)  
Page 51



RT/SK2.5-FLD (RDT2.5-CFCLD)  
Page 51



RT/SF4-2L  
Page 52



RT/SF4-2L-LD  
Page 52

■ General Terminal Blocks

Page 55



RT/SG2.5 (RTX2.5)  
Page 56



RT/SG4 (RTX4)  
Page 56



RT/SG6 (RTX6)  
Page 57



RT/SG10 (RTX10)  
Page 57

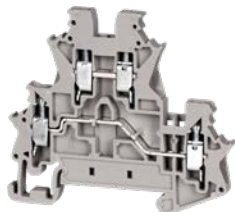

RT/SG2.5-2L  
Page 58



RT/SG4-2L  
Page 58

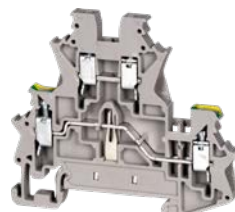

RT/SG2.5-2LE  
Page 59

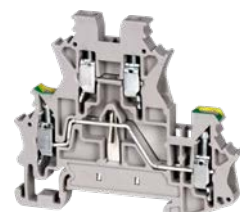

RT/SG4-2LE  
Page 59

Protective General Terminal Blocks

Page 61



RT/SG2.5-E (RETX2.5)  
Page 62



RT/SG4-E (RETX4)  
Page 62



RT/SG6-E (RETX6)  
Page 63



RT/SG10-E (RETX10)  
Page 63

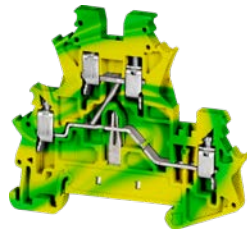

RT/SG2.5-2L2E  
Page 64

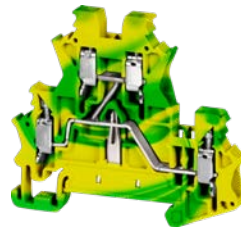

RT/SG4-2L2E  
Page 64

Push-In Connection Terminal Blocks

Page 67

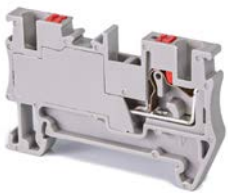

RT/PG2.5 (RPIT2.5)  
Page 70



RT/PG4 (RPIT4)  
Page 70

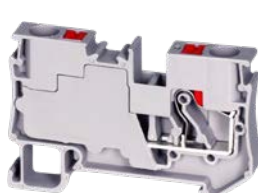

RT/PG6 (RPIT6)  
Page 71



RT/PG10  
Page 71



RT/PG16  
Page 70

Earth Push-In Protective Terminal Blocks

Page 75



RT/PG2.5-E (RPET2.5)  
Page 74



RT/PG4-E (RPET4)  
Page 74

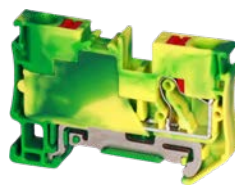

RT/PG6-E (RPET6)  
Page 75



RT/PG10-E  
Page 75



RT/PG16-E  
Page 76

Multi Level Push-In Terminal Blocks

Page 81



RT/PG2.5-2L (DPIT2.5)  
page 80



RT/PG4-2L (DPIT4)  
Page 80



RT/PG4-2LE  
Page 81



RT/PG2.5-3L0E5  
Page 81



RT/PG2.5-3L  
Page 84

Multi Conductor Push-In Terminal Blocks

Page 87

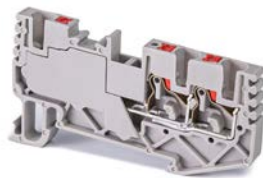

RT/PG2.5-1/2 (RPIT2.5-1/2)  
Page 84



RT/PG2.5-2/2 (RPIT2.5-2/2)  
page 84

Disconnect Push-in Terminal Blocks

Page 91

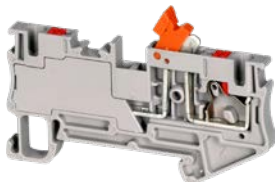

RT/PK2.5  
Page 92

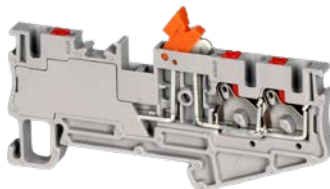

RT/PK2.5-1/2  
page 92

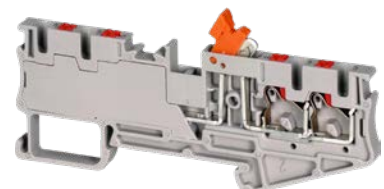

RT/PK2.5-2/2  
page 93

High Current Terminal Blocks

Page 95



RT/SH70 (RTB70)  
Page 96



RT/SH95 (RTB95)  
Page 96



RT/SH150 (RTB150)  
Page 97



RT/SH240 (RTB240)  
Page 73

Transformer Terminal Blocks

Page 99



RT/TC4 (RT4)  
Page 99

Strip Terminal Block Series

Page 101



RT/SS2.5 (RMT2.5)  
Page 102



RT/SS6 (RMT6)  
Page 102



RT/SS16 (B16)  
Page 103

Splicing Terminal Blocks

Page 105



RT/LH4  
Page 105

# Terminal Blocks Accessories

## Marking Systems

Page 107



**NS5**  
Page 108



**NS6**  
Page 108



**NS6.4**  
Page 108



**NS8**  
Page 108



**NS10**  
Page 108



**LB/1**  
Page 85



**LB/2**  
Page 85



**ELB/1**  
Page 85



**ELB/4**  
Page 97



**Marking Holder**  
Page 109

## End Plates And Partitions

Page 110



**End Plate**  
Page 110



**Partition**  
Page 110



**Small Partition**  
Page 111



**General Partition**  
Page 111



**Cover Base**  
Page 111

## End Brackets

Page 112

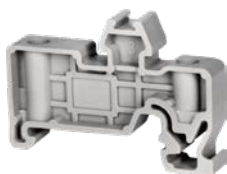

**EB/1**  
Page 112



**EB/2**  
Page 112



**EB/3**  
Page 112



**EB/4**  
Page 112

Test Sockets

Page 113



Test Socket  
Page 113

Moveable Links

Page 113



Moveable Cross Connection (Link)  
Page 113

Cross Connection

Page 114



Screw Cross-Connection Bar  
Page 114



Bridge Comb  
Page 115



Bridge Screwless  
Page 115

# Din Rail Socket Outlet

■ Din Rail Socket Outlet

Page 117



**DSO**  
Page 118

**DSO-LD**  
Page 118

# Switch Disconnectors

■ Switch Disconnectors

Page 121



**RB/I (Isolator)**  
Page 122



**RFH ( Fuse-Switch Disconnectors )**  
Page 124

# Circuit Protection

■ Circuit Protection

Page 129



**RB/M, RB/MD (MCB)**  
Page 130



**RB/M-CB,FB (Auxiliary Contact)**  
Page 134



**RB/RC (RCCB)**  
Page 136



**RB/RO (RCBO)**  
Page 138

# Mounting Rails and Accessories

Mounting Rails and Accessories

Page 141



**TH35 - 7.5/S**  
Page 142



**TH35 - 15/S**  
Page 142



**TH35 - 7.5/HG**  
Page 143



**TH35 - 15/HG**  
Page 143



**ARS/M6**  
Page 144



**EC-TH**  
Page 144

# Wiring Duct Systems

Wiring Duct Systems

Page 147



**RWD Series** ( Slotted Wiring Duct )  
Page 148



**HWD Series** ( Non-Slotted Wiring Duct )  
Page 153

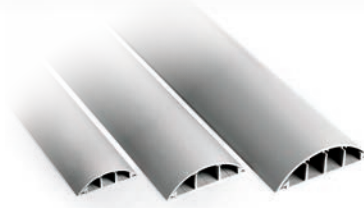

**OWD Series** ( Onfloor Wiring Duct )  
Page 155

# Nylon Cable Ties

Nylon Cable Ties

Page 159



**Nylon Cable Tie**  
Page 159

# Control Switches

Control Switches and Accessories

Page 161



Push-Buttons  
Page 163



Double Push-Buttons  
Page 167



Emergency Stop-Button  
Page 169



Selector Switches  
Page 170



C-FB  
Page 178



C-DPB  
Page 178



G-ESTR  
Page 178



Contacts  
Page 179

# Panel Signal Light

Panel Signal Light

Page 181



IN 22 Series  
Page 182



RSL 22 Series  
Page 182



RCI 22 Series  
Page 183



Lamp  
Page 184

# Tbloc Products

## ■ Crimping Terminal

Page 187



**Ferrule**  
Page 188



**Connector**  
Page 191



**Lug**  
Page 196



**Circular kit**  
Page 199



**Rectangular kit**  
Page 200

## ■ Marking Solution

Page 203



**CM**  
Page 204



**TBET**  
Page 204



**TYPET**  
Page 204



**ASE60**  
Page 205



**TBSL**  
Page 205

Relay Modules



TRB LT  
Page 208



TS-V TRB  
Page 214



TS-V TRB Accessories  
Page 216



PINT-R1  
Page 218



PINT-1C  
Page 220

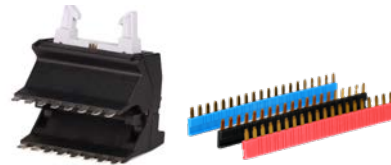

PINT-1C Accessories  
Page 222

Distribution Terminal Blocks



SDB  
Page 226



TDB  
Page 229



FDB  
Page 233

**RAAD**  <sup>®</sup>





**RAAD**  <sup>®</sup> Electrical Connection for  
Technological Components  
*Confidence in Connection*

# Universal Terminal Blocks

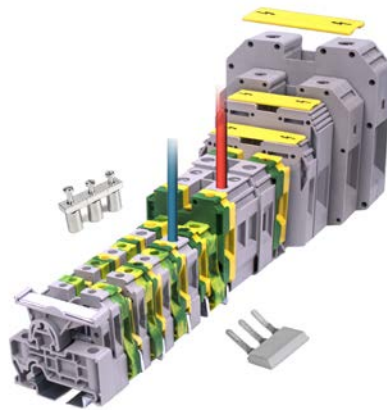

## Screw Connections

This is the most popular of all known methods of connection. No other connection method allows such high contact forces to be produced in such a small space as a screw. RAAD terminal block screw connection is easy to operate with a standard screwdriver or allen wrench, suitable for all types of conductors without special preparation, absolutely gas tight and vibration proof.

## Reliable Clamping

Most RAAD products use a clamping unit system which has been proven millions of times, world-wide. The clamping units as well as clamping screws are produced from hardened steel. When the clamping screw is tightened, the resultant force causes the upper thread overlap to spring open, thus causing a locking action to be exerted on the screw and an excellent resistance against vibration is achieved.

## RAAD offers the RT/SU series with the following advantages:

- Combination foot for TH35 mounting rails
- Terminal insulation body polyamide
- Easy to tighten by screwdriver and allen wrench
- Closed cable entry to prevent wire splitting
- Best connection of the conductor, needing no special cable preparation
- Appropriate for different cross-sections of rigid and flexible conductors
- Similar end plates and partitions for several types
- Pre-assembled and divisible cross-connection system and easy removable unwanted cross-connection
- Offering protective conductor terminals, suitable for various sizes of terminals
- Having marker strips simultaneously mountable on some sizes of the terminal

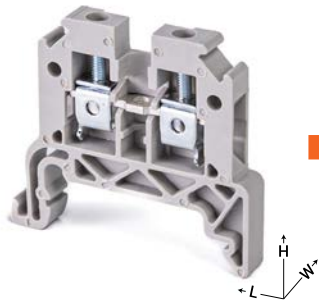

### RT/SU2.5

(RTP2.5)



### RT/SU2.5-H

(RTP2.5-H)



Technical data	RT/SU2.5		RT/SU2.5-H			
	Voltage(V)	Current(A)	Voltage(V)	Current(A)		
IEC 60947-7-1	800	24	500	24		
IEC/EN 60079-7	500	24	320	24		
<b>IEC 60947-7-1 rated data</b>						
Impulse voltage (kV)	6		6			
Pollution degree/ Voltage category/Material group	3/III/1		3/III/1			
Maximum Current (A)	32		32			
Maximum Conductor Cross-section (mm <sup>2</sup> )	4		4			
Cross-section (mm <sup>2</sup> )	2.5		2.5			
Description	Type	Ordering No.	Qty.	Type	Ordering No.	Qty.
Terminal block, for mounting on TH 35-7.5, 15	RT/SU2.5	60104020	100	RT/SU2.5H	60104010	100
End plate Width (mm)	EP-RTP2.5 1.5	60202020	100	EP-RTP2.5H-10 1.2	60202021	50
Partition Width (mm)	P-RTP2.5 1.6	60203010	100	P-RTP2.5H-10 1.6	60203011	50
Small partition no loss of pitch	SP-2.5-10	6020304001	100	SP-2.5-10	6020304001	100
End bracket, for TH 35-7.5, 15 width (mm)	EB/4 8	6020101006	50	EB/4 8	6020101006	50
	EB/3 10	6020101003	50	EB/3 10	6020101003	50
	EB/1 9.5	6020101001	50	EB/1 9.5	6020101001	50
Cross-connection	CC10-2.5 10-pos.	6020502009	10	CC10-2.5 10-pos.	6020502009	50
	CC3-2.5 3-pos.	6020502002	50	CC3-2.5 3-pos.	6020502002	50
	CC2-2.5 2-pos.	6020502001	50	CC2-2.5 2-pos.	6020502001	50
max. current (A)	24			24		
Bridge-comb	BC 10-2.5 10-pos.	6020504009	10	BC 10-2.5 10-pos.	6020504009	10
	BC 3-2.5 3-pos.	6020504002	50	BC 3-2.5 3-pos.	6020504002	50
	BC 2-2.5 2-pos.	6020504001	50	BC 2-2.5 2-pos.	6020504001	50
max. current (A)	24			24		
Test Socket	TS3/6/2.3	6020402001	50	TS3/6/2.3	6020402001	50
Screw Driver	0.5x3.0	-	-	0.5*3.0	-	-
Marking Tags	NS6	For details see Accessories		NS6	For details see Accessories	
Marking Holder	Marking Holder	6032100001	10	Marking Holder	6032100001	10
Strip Lable	TBSL 22x20	For details see Accessories		TBSL 22x20	For details see Accessories	
Color (Color Code is the last 2 digits of the Ordering No.)						
<b>Dimensions (mm)</b>	<b>W / L / H</b>			<b>W / L / H</b>		
Width/Length/Height, TH 35-7.5	6/45.2/42			6/45.2/48.5		
Width/Length/Height, TH 35-15	6/45.2/49.5			6/45.2/56		
<b>Connection capacity</b>						
Rigid Solid (mm <sup>2</sup> )	0.5-4			0.5-4		
Rigid stranded (mm <sup>2</sup> )	0.5-4			0.5-4		
Flexible (mm <sup>2</sup> )	0.5-2.5			0.5-2.5		
American Wire Gauge (AWG)	20-12			20-12		
<b>IEC test gauge</b>						
<b>A3</b>						
Stripping length (mm)	10			10		
<b>Clamping screw</b>						
<b>M2.5</b>						
Tightening torque (N.m)	0.6			0.4-0.6		
<b>Insulation material</b>						
<b>PA</b>						

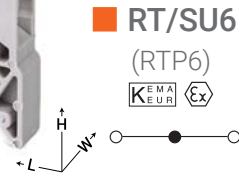
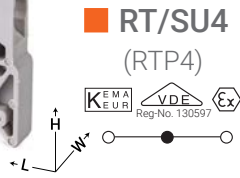

Technical data	RT/SU4			RT/SU6		
	Voltage(V)	Current(A)		Voltage(V)	Current(A)	
IEC 60947-7-1	800	32		800	41	
IEC/EN 60079-7	500	32		500	41	
<b>IEC 60947-7-1 rated data</b>						
Impulse voltage (kV)	6			8		
Pollution degree/Voltage category/Material group	3/III/I			3/III/I		
Maximum Current (A)	41			57		
Maximum Conductor Cross-section (mm <sup>2</sup> )	6			10		
Cross-section (mm <sup>2</sup> )	4			6		
<b>Description</b>	<b>Type</b>	<b>Ordering No.</b>	<b>Qty.</b>	<b>Type</b>	<b>Ordering No.</b>	<b>Qty.</b>
Terminal block, for mounting on TH 35-7.5, 15	RT/SU4	60104030	100	RT/SU6	60104040	80
End plate Width (mm)	EP-RTP2.5H-10 1.2	60202021	100	EP-RTP2.5H-10 1.2	60202021	50
Partition Width (mm)	P-RTP2.5H-10 1.6	60203010	100	P-RTP2.5H-10 1.6	60203011	50
Small partition no loss of pitch	SP-2.5-10	6020304001	100	SP-2.5-10	6020304001	100
End bracket, for TH 35-7.5, 15 width (mm)	EB/4 8 EB/3 10 EB/1 9.5	6020101006 6020101003 6020101001	50 50 50	EB/4 8 EB/3 10 EB/1 9.5	6020101006 6020101003 6020101001	50 50 50
Cross-connection	CC10-4 10-pos. CC3-4 3-pos. CC2-4 2-pos. 32	6020502009 6020502002 6020502001	10 50 50	CC10-6 10-pos. CC3-6 3-pos. CC2-6 2-pos. 41	6020502209 6020502202 6020502201	10 50 50
max. current (A)				41		
Bridge-comb	BC10-4 10-pos. BC3-4 3-pos. BC2-4 2-pos. 32	6020504109 6020504102 6020504101	10 50 50	JEB10-6 10-pos. JEB3-6 3-pos. JEB2-6 2-pos. 41	6020506009 6020506002 6020506001	10 50 50
max. current (A)				41		
Test Socket	TS3/6/2.3	6020402001	50	-	-	-
Screw Driver	0.5x3.0	-	-	TS6	6020401005	50
Marking Tags	NS6.4	For details see Accessories		NS8	For details see Accessories	
Marking Holder	Marking Holder	6032100001	10	Marking Holder	6032100001	10
Strip Lable	TBSL 22x20	For details see Accessories		TBSL 22x20	For details see Accessories	
Color (Color Code is the last 2 digits of the Ordering No.)						
<b>Dimensions (mm)</b>	<b>W / L / H</b>			<b>W / L / H</b>		
Width/Length/Height, TH 35-7.5	6.4/45.2/48.5			8/45.2/48.5		
Width/Length/Height, TH 35-15	6.4/45.2/56			8/45.2/56		
<b>Connection capacity</b>						
Rigid Solid (mm <sup>2</sup> )	0.5-6			0.5-10		
Rigid stranded (mm <sup>2</sup> )	0.5-6			0.5-10		
Flexible (mm <sup>2</sup> )	0.5-4			0.5-6		
American Wire Gauge (AWG)	20-10			20-8		
<b>IEC test gauge</b>	<b>A4</b>			<b>A5</b>		
Stripping length (mm)	12			12		
<b>Clamping screw/ Tightening torque (N.m)</b>	<b>M3/0.8</b>			<b>M3.5/1.2</b>		
Insulation material	PA			PA		



**RT/SU10**

(RTP10)

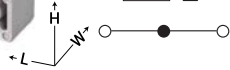

**RT/SU16**

(RTP16)

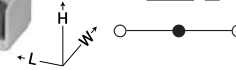

Technical data	RT/SU10		RT/SU16			
	Voltage(V)	Current(A)	Voltage(V)	Current(A)		
IEC 60947-7-1	800	57	1000	76		
IEC/EN 60079-7	500	57	630	76		
<b>IEC 60947-7-1 rated data</b>						
Impulse voltage (kV)	8		8			
Pollution degree/ Voltage category/Material group	3/III/1		3/III/1			
Maximum Current (A)	76		-			
Maximum Conductor Cross-section (mm <sup>2</sup> )	16		-			
Cross-section (mm <sup>2</sup> )	10		16			
Description	Type	Ordering No.	Qty.	Type	Ordering No.	Qty.
Terminal block, for mounting on TH 35-7.5, 15	RT/SU10	60104050	60	RT/SU16	60104060	50
End plate	EP-RTP2.5-H-10	60202021	100	-	-	-
Width (mm)	1.2			-	-	-
Partition	P-RTP2.5-H-10	60203010	100	-	-	-
Width (mm)	1.6			-	-	-
Small partition no loss of pitch	SP-2.5-10	6020304001	100	-	-	-
Partition width (mm)	-	-	-	GP 3	6020305005	20
End bracket, for TH 35-7.5, 15 width (mm)	EB/4 8	6020101006	50	EB/4 8	6020101006	50
	EB/3 10	6020101003	50	-	-	-
	EB/1 9.5	6020101001	50	-	-	-
End bracket, for G32 TH35-7.5, 15 Width (mm)	-	-	-	EB/2 10	6020101002	50
Cross-connection	CC10-10 10-pos.	6020502009	10	CC10-16 10-pos.	6020502409	10
	CC3-10 3-pos.	6020502002	50	CC3-16 3-pos.	6020502402	20
	CC2-10 2-pos.	6020502001	50	CC2-16 2-pos.	6020502401	20
max. current (A)	57			76		
Test Socket	TS3/8/4	6020402002	50	TS3.5/8/4	6020402003	50
	TS6	6020401005	50	-	-	-
Screw Driver	1.0*4.0	-	-	1.0x5.5	-	-
Marking Tags	NS10	For details see Accessories		NS10	For details see Accessories	
Marking Holder	Marking Holder	6032100001	10	Marking Holder	6032100001	10
Strip Lable	TBSL 22x20	For details see Accessories		TBSL 22x20	For details see Accessories	
Color (Color Code is the last 2 digits of the Ordering No.)						
<b>Dimensions (mm)</b>	<b>W / L / H</b>		<b>W / L / H</b>			
Width/Length/Height, TH 35-7.5	10/45.2/48.5		12.5/49.5/61.5			
Width/Length/Height, TH 35-15	10/45.2/56		12.5/49.5/69			
<b>Connection capacity</b>						
Rigid Solid (mm <sup>2</sup> )	0.5-16		0.5-16			
Rigid stranded (mm <sup>2</sup> )	0.5-16		0.5-16			
Flexible (mm <sup>2</sup> )	0.5-10		0.5-16			
American Wire Gauge (AWG)	20-6		20-6			
<b>IEC test gauge</b>	<b>B6</b>		<b>B7</b>			
Stripping length (mm)	12		12.3			
<b>Clamping screw/ Tightening torque (N.m)</b>	<b>M4/1.5</b>		<b>M5/2.5</b>			
Insulation material	PA		PA			

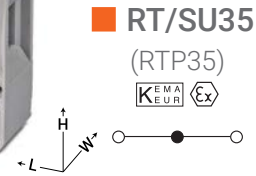
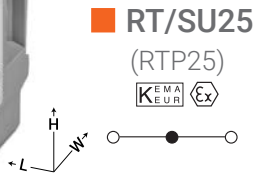

Technical data	RT/SU25		RT/SU35	
	Voltage(V)	Current(A)	Voltage(V)	Current(A)
IEC 60947-7-1	1000	101	1000	125
IEC/EN 60079-7	630	101	630	124
<b>IEC 60947-7-1 rated data</b>				
Impulse voltage (kV)	8		8	
Pollution degree/Voltage category /Material group	3/III/I		3/III/I	
Cross-section (mm <sup>2</sup> )	25		35	

Description	Type	Ordering No.	Qty.	Type	Ordering No.	Qty.
Terminal block, for mounting on TH 35-7.5, 15	RT/SU25	60104070	50	RT/SU35	60104080	20
Partition width (mm)	GP 3	6020305005	20	GP 3	6020305005	20
End bracket for G32 TH 35-7.5, 15 width (mm)	EB/2 10	6020101002	50	EB/2 10	6020101002	50
Cross-connection	CC10-25 10-pos. CC3-25 3-pos. CC2-25 2-pos.	6020502419 6020502412 6020502411	10 20 20	CC10-35 10-pos. CC3-35 3-pos. CC2-35 2-pos.	6020502439 6020502432 6020502431	10 20 20
max. current (A)	101			114		
Test Socket	TS4/8/4	6020402004	50	TS4/8/4	6020402004	50
Screw Driver	1.0x5.5	-	-	1.2x6.5	-	-
Marking Tags	NS10 RAAD recommended	For details see Accessories		NS10 RAAD recommended	For details see Accessories	
Marking Holder	Marking Holder	6032100001	10	Marking Holder	6032100001	10
Strip Lable	TBSL 22x20	For details see Accessories		TBSL 22x20	For details see Accessories	
Color (Color Code is the last 2 digits of the Ordering No.)		01   02   04   05   06   07   09			01   02   04   05   06   07   09	
<b>Dimensions (mm)</b>	<b>W / L / H</b>			<b>W / L / H</b>		
Width/Length/Height, TH 35-7.5	13.6/49.5/61.5			16.5/52/64		
Width/Length/Height, TH 35-15	13.6/49.5/69			16.5/52/71.5		
<b>Connection capacity</b>						
Rigid Solid (mm <sup>2</sup> )	0.5-16			1.5-16		
Rigid stranded (mm <sup>2</sup> )	0.5-25			1.5-35		
Flexible (mm <sup>2</sup> )	0.5-25			1.5-35		
American Wire Gauge (AWG)	20-4			16-2		
<b>IEC test gauge</b>	<b>B8</b>			<b>B9</b>		
Stripping length (mm)	12.3			14.9		
<b>Clamping screw</b>	<b>M5</b>			<b>M6</b>		
Tightening torque (N.m)	2.5			3.5		
<b>Insulation material</b>	<b>PA</b>			<b>PA</b>		



### RT/SU50

(RTP50)



### RT/SU70

(RTP70)



Technical data	RT/SU50		RT/SU70	
	Voltage(V)	Current(A)	Voltage(V)	Current(A)
IEC 60947-7-1 IEC/EN 60079-7	1000 800	150 140	1000 -	192 -
<b>IEC 60947-7-1 rated data</b>				
Impulse voltage (kV)	8		8	
Pollution degree/ Voltage category/Material group	3/III/1		3/III/1	
Cross-section (mm <sup>2</sup> )	50		70	

Description	Type	Ordering No.	Qty.	Type	Ordering No.	Qty.
Terminal block, for mounting on TH 35-7.5, 15	RT/SU50	60104090	20	RT/SU70	60104100	10
Partition width (mm)	GP 3	6020305005	20	-	-	-
End bracket for G32 TH 35-7.5, 15 width (mm)	EB/2 10	6020101002	50	EB/2 10	6020101002	50
Cross-connection	CC3-50 3-pos. CC2-50 2-pos. 132	6020502452 6020502451	10 10	CC3-70 3-pos. CC2-70 2-pos.	6020502472 6020502471	10 10
max. current (A)						
Allen wrench	4	-	-	6	-	-
Marking Tags	NS10 RAAD recommended	For details see Accessories		NS10 RAAD recommended	For details see Accessories	
Marking Holder	Marking Holder	6032100001	10	Marking Holder	6032100001	10
Strip Lable	TBSL 22x20	For details see Accessories		TBSL 22x20	For details see Accessories	
Color (Color Code is the last 2 digits of the Ordering No.)						
<b>Dimensions (mm)</b>	<b>W / L / H</b>			<b>W / L / H</b>		
Width/Length/Height, TH 35-7.5	20/67/72			22/67/87.5		
Width/Length/Height, TH 35-15	20/67/79.5			22/67/95		
<b>Connection capacity</b>						
Rigid Solid (mm <sup>2</sup> )	6-16			6-16		
Rigid stranded (mm <sup>2</sup> )	6-50			6-70		
Flexible (mm <sup>2</sup> )	10-50			10-70		
American Wire Gauge (AWG)	10-0			8-00		
<b>IEC test gauge</b>	<b>B10</b>			<b>B11</b>		
Stripping length (mm)	19			19		
<b>Clamping screw</b>	<b>M8</b>			<b>M8</b>		
Tightening torque (N.m)	4.5-8			10		
<b>Insulation material</b>	<b>PA</b>			<b>PA</b>		

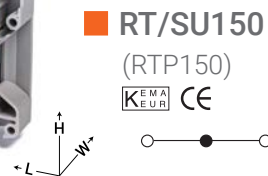
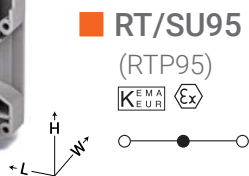

Technical data	RT/SU95		RT/SU150	
	Voltage(V)	Current(A)	Voltage(V)	Current(A)
IEC 60947-7-1	1000	232	1000	309
IEC/EN 60079-7	750	210	-	-
<b>IEC 60947-7-1 rated data</b>				
Impulse voltage (kV)	8		8	
Pollution degree/Voltage category /Material group	3/III/I		3/III/I	
Cross-section (mm <sup>2</sup> )	95		150	

Description	Type	Ordering No.	Qty.	Type	Ordering No.	Qty.
Terminal block, for mounting on G 32 TH 35-15	RT/SU95	60104110	5	RT/SU150	60104120	5
End bracket for G32 TH 35-7.5, 15 width (mm)	EB/2 10	6020101002	50	EB/2 10	6020101002	50
Cross-connection max. current (A)	CC3-95 3-pos. CC2-95 2-pos. 200	6020502511 6020502491	10 10	CC3-150 3-pos. CC2-150 2-pos. 250	6020502512 6020502511	10 10
Allen wrench	6	-	-	8	-	-
Marking Tags	NS10 RAAD recommended	For details see Accessories		NS10 RAAD recommended	For details see Accessories	
Marking Holder	Marking Holder	6032100001	10	Marking Holder	6032100001	10
Strip Lable	TBSL 22x20	For details see Accessories		TBSL 22x20	For details see Accessories	
Color (Color Code is the last 2 digits of the Ordering No.)	01   05   09			01   05   09		
<b>Dimensions (mm)</b>	<b>W / L / H</b>			<b>W / L / H</b>		
Width/Length/Height, TH 35-7.5	25.5/85.5/94			31/102/112.5		
Width/Length/Height, TH 35-15	2.5/85.5/101.5			31/102/120		
<b>Connection capacity</b>						
Rigid Solid (mm <sup>2</sup> )	6-16			6-16		
Rigid stranded (mm <sup>2</sup> )	6-95			6-150		
Flexible (mm <sup>2</sup> )	10-95			10-150		
American Wire Gauge (AWG)	10-3/0			10-300 (Kcmil)		
<b>IEC test gauge</b>	<b>B12</b>			<b>B14</b>		
Stripping length (mm)	24.5			27		
<b>Clamping screw</b>	<b>M8</b>			<b>M10</b>		
Tightening torque (N.m)	14			18-22		
<b>Insulation material</b>	<b>PA</b>			<b>PA</b>		



**RAAD**  <sup>®</sup> Electrical Connection for  
Technological Components  
*Confidence in Connection*

# Protective Conductor Terminal Blocks

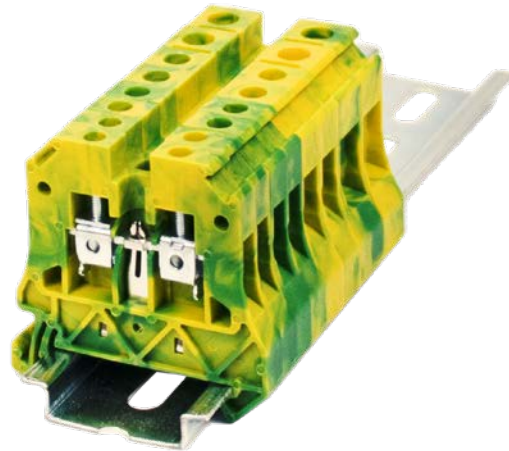

- Mountable on both TH35 and G32 mounting rails for RT/SU-E and easy assembling on TH35 mounting rails in the RT/SU-SO
- Green-yellow insulated body in RT/SU-E, and partially green-yellow insulated body in RT/SU-SO made of PA material
- Designed to provides proper electrical and mechanical connection with its mounting rail, so that it can be used to provide conductor busbar
- Protective conductor terminal blocks share the same space-saving characteristics and design specifications as the RT/SU series
- Used for connecting PE and PEN conductors, regarding the rated cross-section to be more than 10 mm<sup>2</sup> for PEN function, as specified in the below table

**Table A.1 - Maximum short-time withstand currents allocated to the rail profile and thermal rated current of a PEN busbar**

IEC 60947-7-2				
Rail profile	Material	Equivalent E-Cu cross-section mm <sup>2</sup>	Short-time withstand current 1 s kA	Thermal rated current of a PEN busbar A
"Top hat" rail IEC 60715/TH 15-5.5	Steel **	10	1.2	-
	Copper *	25	3	101
	Aluminium *	16	1.92	76
G-type rail IEC 60715/G32	Steel **	35	4.2	-
	Copper *	120	14.4	269
	Aluminium *	70	8.4	192
"Top hat" rail IEC 60715/TH 35-7.5	Steel **	16	1.92	-
	Copper *	50	6	150
	Aluminium *	35	4.2	125
"Top hat" rail IEC 60715/TH 35-15	Steel **	50	6	-
	Copper *	150	18	309
	Aluminium *	95	11.4	232

\* Copper or aluminium alloys selected by the manufacturer of terminal block assembly to achieve the values in the table.

\*\* Steel protective conductor busbars are not allowed to be used as a PEN conductor.



RT/SU2.5-E

(RET2.5)

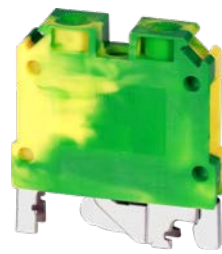
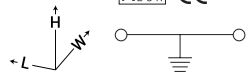

RT/SU4-E

(RET4)

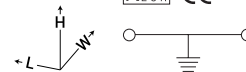

IEC 60947-7-2 rated data	RT/SU2.5-E	RT/SU4-E
Impulse voltage (kV)	6	6
Pollution degree/Voltage category/Material group	3/III/1	3/III/1
Current (A)	-	-
Cross section (mm <sup>2</sup> )	2.5	4

Description	Type	Ordering No.	Qty.	Type	Ordering No.	Qty.
Terminal block, for mounting on G 32 TH35-7.5,15	RT/SU2.5-E	6010601001	50	RT/SU4-E	6010601002	50
Marking Tags	NS6	For details see Accessories		NS6.4	For details see Accessories	
Marking Holder	Marking Holder	6032100001	10	Marking Holder	6032100001	10
Strip Lable	TBSL 22x20	For details see Accessories		TBSL 22x20	For details see Accessories	
Screw Driver	0.5*3.0 0.5*3.0	-	-	0.5*3.0 0.5*3.0	-	-
Color						

Dimensions (mm)	W / L / H	W / L / H
Width/Length/Height, TH 35-7.5	6/42.5/42	6.4/42.5/48
Width/Length/Height, TH 35-15	6/42.5/49.5	6.4/42.5/55.5
Width/Length/Height, G32	6/42.5/46	6.4/42.5/52
Connection capacity		
Rigid Solid (mm <sup>2</sup> )	0.5-4	0.5-4
Rigid stranded (mm <sup>2</sup> )	0.5-4	0.5-4
Flexible (mm <sup>2</sup> )	0.5-2.5	0.5-4
American Wire Gauge (AWG)	20-12	20-12
IEC test gauge	A3	A4
Stripping length (mm)	10	12
Clamping screw/Tightening torque (N.m)	M2.5 / 0.4	M3 / 0.5
Center screw/Tightening torque (N.m)	M3 / 0.5	M3 / 0.5
Insulation material	PA	PA

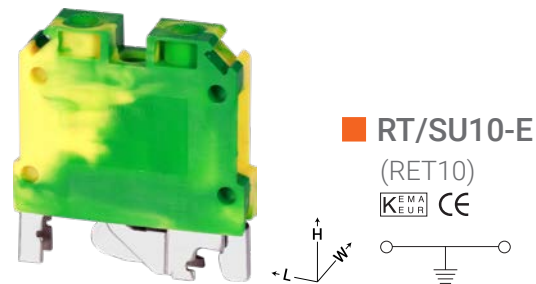
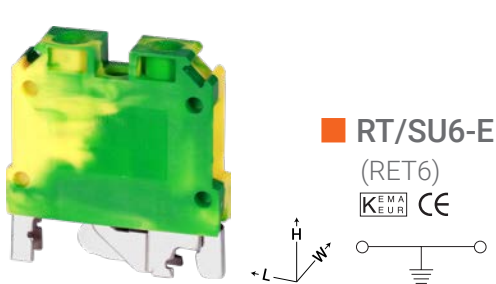

IEC 60947-7-2 rated data	RT/SU6-E	RT/SU10-E
Impulse voltage (kV)	8	8
Pollution degree/Voltage category/Material group	3/III/I	3/III/I
Current (A)	-	57
Cross section (mm <sup>2</sup> )	6	10

Description	Type	Ordering No.	Qty.	Type	Ordering No.	Qty.
Terminal block, for mounting on G 32  TH35-7.5,15	RT/SU6-E	6010601003	25	RT/SU10-E	6010601004	25
Marking Tags	NS8	For details see Accessories		NS10	For details see Accessories	
Marking Holder	Marking Holder	6032100001	10	Marking Holder	6032100001	10
Strip Lable	TBSL 22x20	For details see Accessories		TBSL 22x20	For details see Accessories	
Screw Driver	0.6*3.5 1.0*4.0	-	-	1.0*4.0 1.0*4.0	-	-
Color						

Dimensions (mm)	W / L / H	W / L / H
Width/Length/Height, TH 35-7.5	8/42.5/48	10/42.5/48
Width/Length/Height, TH 35-15	8/42.5/55.5	10/42.5/55.5
Width/Length/Height, G32	8/42.5/51	10/42.5/51
Connection capacity		
Rigid Solid (mm <sup>2</sup> )	0.5-10	0.5-16
Rigid stranded (mm <sup>2</sup> )	0.5-10	0.5-16
Flexible (mm <sup>2</sup> )	0.5-6	0.5-10
American Wire Gauge (AWG)	20-8	20-6
IEC test gauge	A5	B6
Stripping length (mm)	12	12
Clamping screw/Tightening torque (N.m)	M3.5 / 1.2	M4 / 1.5
Center screw/Tightening torque (N.m)	M4 / 1.2	M4 / 1.2
Insulation material	PA	PA



### RT/SU16-E

(RET16)

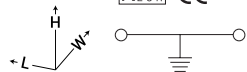

### RT/SU35-E

(RET35)

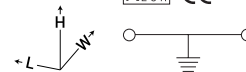

IEC 60947-7-2 rated data	RT/SU16-E	RT/SU35-E
Impulse voltage (kV)	8	8
Pollution degree/Voltage category/Material group	3/III/I	3/III/I
Current (A)	76	125
Cross section (mm <sup>2</sup> )	16	35

Description	Type	Ordering No.	Qty.	Type	Ordering No.	Qty.
Terminal block, for mounting on G 32 TH35-7.5,15	RT/SU16-E	6010601005	20	RT/SU35-E	6010601006	20
Marking Tags	NS10 RAAD recommended	For details see Accessories		NS10 RAAD recommended	For details see Accessories	
Marking Holder	Marking Holder	6032100001	10	Marking Holder	6032100001	10
Strip Lable	TBSL 22x20	For details see Accessories		TBSL 22x20	For details see Accessories	
Screw Driver	1.0*5.5 1.0*4.0	-	-	1.2x6.5 1.0x5.5	-	-
Color						

Dimensions (mm)	W / L / H	W / L / H
Width/Length/Height, TH 35-7.5	12.5/46.5/61.5	16.5/50/64
Width/Length/Height, TH 35-15	12.5/46.5/69	16.5/50/71.5
Width/Length/Height, G32	12.5/46.5/65	16.5/50/67.5
Connection capacity		
Rigid Solid (mm <sup>2</sup> )	0.5-16	1.5-16
Rigid stranded (mm <sup>2</sup> )	0.5-16	1.5-35
Flexible (mm <sup>2</sup> )	0.5-16	1.5-35
American Wire Gauge (AWG)	20-6	16-2
IEC test gauge	B7	B9
Stripping length (mm)	12.3	14.9
Clamping screw/Tightening torque (N.m)	M5 / 2.5	M6 / 3.5
Center screw/Tightening torque (N.m)	M4 / 1.2	M5 / 2
Insulation material	PA	PA

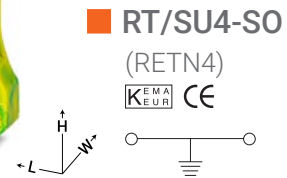
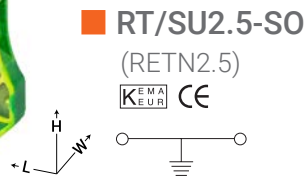

IEC 60947-7-2 rated data	RT/SU2.5-SO	RT/SU4-SO
Impulse voltage (kV)	6	6
Pollution degree/Voltage category/Material group	3/III/I	3/III/I
Current (A)	-	-
Cross section (mm <sup>2</sup> )	2.5	4

Description	Type	Ordering No.	Qty.	Type	Ordering No.	Qty.
Terminal block, for mounting on TH 35-7.5, 15	RT/SU2.5-SO	6010602001	50	RT/SU4-SO	6010602002	50
End plate Width (mm)	EP-RETN2.5-10 1.2	6020206001	50	EP-RETN2.5-10 1.2	6020206001	50
Partition Width (mm)	P-RETN2.5-10 1.6	6020301105	50	P-RETN2.5-10 1.6	6020301105	50
Screw Driver	0.5x3.0	-	-	0.5x3.0	-	-
Marking Tags	NS6	For details see Accessories		NS6.4	For details see Accessories	
Marking Holder	Marking Holder	6032100001	10	Marking Holder	6032100001	10
Strip Lable	TBSL 22x20	For details see Accessories		TBSL 22x20	For details see Accessories	
Color						

Dimensions (mm)	W / L / H	W / L / H
Width/Length/Height, TH 35-7.5	6/48/48	6.4/48/48
Width/Length/Height, TH 35-15	6/48/55.5	6.4/48/55.5
Connection capacity		
Rigid Solid (mm <sup>2</sup> )	0.5-4	0.5-4
Rigid stranded (mm <sup>2</sup> )	0.5-4	0.5-4
Flexible (mm <sup>2</sup> )	0.5-2.5	0.5-4
American Wire Gauge (AWG)	20-12	20-12
IEC test gauge	A3	A4
Stripping length (mm)	10	12
Clamping screw/Tightening torque (N.m)	M2.5 / 0.4-0.6	M3 / 0.5
Insulation material	PA	PA



### RT/SU6-SO

(RETN6)

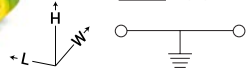

### RT/SU10-SO

(RETN10)

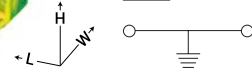

IEC 60947-7-2 rated data	RT/SU6-SO	RT/SU10-SO
Impulse voltage (kV)	8	8
Pollution degree/Voltage category/Material group	3/III/I	3/III/I
Current (A)	-	57
Cross - section (mm <sup>2</sup> )	6	10

Description	Type	Ordering No.	Qty.	Type	Ordering No.	Qty.
Terminal block, for mounting on TH 35-7.5, 15	RT/SU6-SO	6010602003	25	RT/SU10-SO	6010602004	20
End plate	EP-RETN2.5-10	6020206001	50	EP-RETN2.5-10	6020206001	50
Width (mm)	1.2			1.2		
Partition	P-RETN2.5-10	6020301105	50	p-RETN2.5-10	6020301105	50
Width (mm)	1.6			1.6		
Screw Driver	0.6x3.5	-	-	1.0*4.0	-	-
Marking Tags	NS8	For details see Accessories		NS10	For details see Accessories	
Marking Holder	Marking Holder	6032100001	10	Marking Holder	6032100001	10
Strip Lable	TBSL 22x20	For details see Accessories		TBSL 22x20	For details see Accessories	
Color						

Dimensions (mm)	W / L / H	W / L / H
Width/Length/Height, TH 35-7.5	8/48/48	10/48/48
Width/Length/Height, TH 35-15	8/48/55.5	10/48/55.5
<b>Connection capacity</b>		
Rigid Solid (mm <sup>2</sup> )	0.5-10	0.5-16
Rigid stranded (mm <sup>2</sup> )	0.5-10	0.5-16
Flexible (mm <sup>2</sup> )	0.5-6	0.5-10
American Wire Gauge (AWG)	20-8	20-6
<b>IEC test gauge</b>	<b>A5</b>	<b>B6</b>
Stripping length (mm)	12	12
<b>Clamping screw/Tightening torque (N.m)</b>	<b>M3.5 / 1.2</b>	<b>M4 / 1.5</b>
Insulation material	PA	PA





**RAAD**  <sup>®</sup> Electrical Connection for  
Technological Components  
*Confidence in Connection*

# Multi Level Terminal Blocks

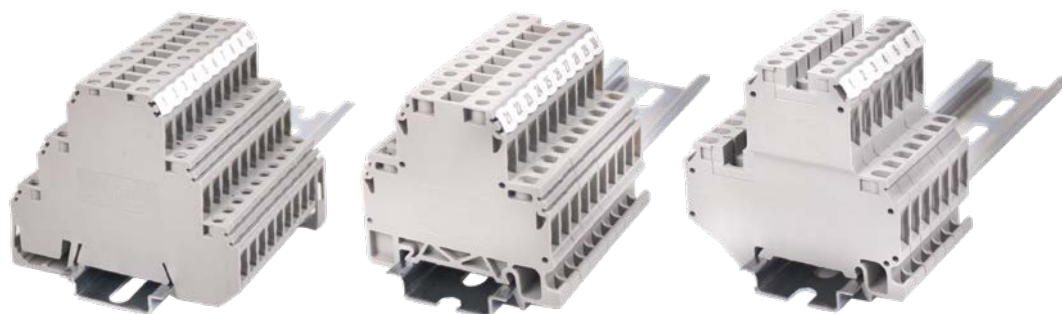

## This section consists of double-level (RT/SU-2L Series) and three-level (RT/SU3L series) terminal blocks.

RAAD screw multi-Level terminal blocks enjoy the space-saving benefit, and the following advantages are met:

- As for foot connection, RAAD screw multi-level terminals can be mounted on the TH35 mounting rail.
  - Terminal block type RT/SU-2L-L has four accessible input/output connecting ports by an internal link between two upper and lower levels. These terminals can be used as distributed terminals same as one to three or one to two branches, in the equipotential circuits, RT/SU4-2L-L can also be connected to adjacent terminals, through cross-connection in the lower level.
  - It is remarkable in RT/SU4-2L that due to its double wiring density, the upper level is offset laterally by half of the terminal block width due to effective accessibility of the lower level, and better view of lower labels and entry points.
  - The end plates of RT/SU4-2L compensate for the level offset at the beginning and end of the terminal strips. Thus other terminal blocks align directly.
  - RT/SU-3L and RT/SU-3L0E5 terminal blocks were specially developed for space-saving wiring in three wired elements such as motors and sensors, e.g. phase-neutral-earth connection or positive-negative-earth/shield connection.
  - In designing RT/SU2.5-2L-L, RT/SU4-2L-L, special capabilities are offered for installing electronic elements. RAAD double-Level terminal blocks are used
    - for voltage rectifying, monitoring, electronic elements, fine switching, and test circuits.
- Furthermore, a number of circuits, in which the terminals are applied, are offered (for details see diagrams as follows). Any other type of circuit is offered on request.
- Different colors are available upon request.
  - RAAD three-level terminal block was specially developed for space-saving wiring in 3 wired elements such as motors and sensors, e.g. phaseneutral-earth connection or positive-negative-earth / shield connection

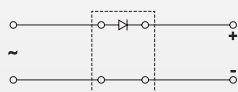

Example for rectifying purposes

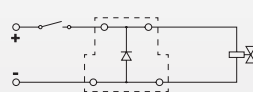

Example for fine switching a DC load

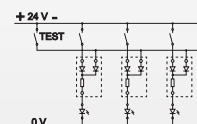

Example for lamp test circuit

- Some of the circuits designed by using small components in the RAAD double-Level terminal blocks given as below:

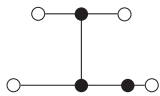

RT/SU4-2L-L

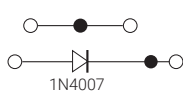

RT/SU4-2L-D1

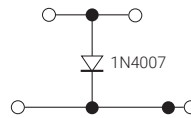

RT/SU4-2L-D2

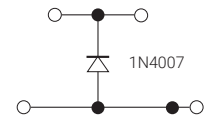

RT/SU4-2L-D3

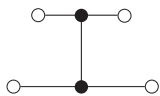

RT/SU2.5/4-2L-L

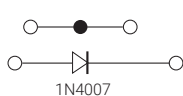

RT/SU2.5/4-2L-D1

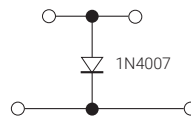

RT/SU2.5/4-2L-D2

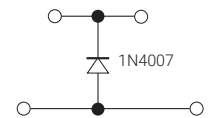

RT/SU2.5/4-2L-D3

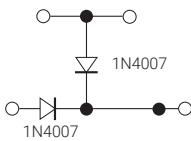

RT/SU4-2L-D4

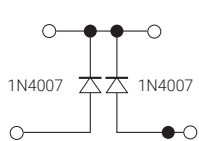

RT/SU4-2L-D5

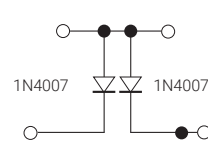

RT/SU4-2L-D6

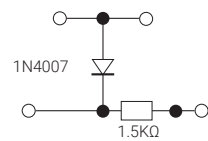

RT/SU4-2L-DR1

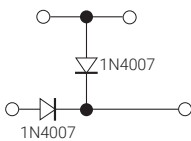

RT/SU2.5/4-2L-D4

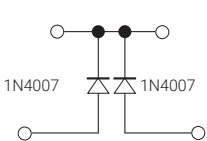

RT/SU2.5/4-2L-D5

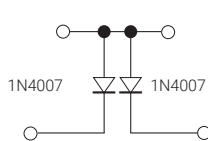

RT/SU2.5/4-2L-D6

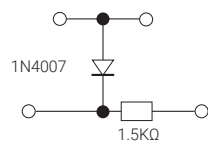

RT/SU2.5/4-2L-DR1

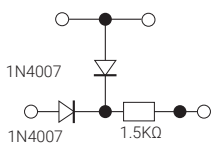

RT/SU4-2L-DR2

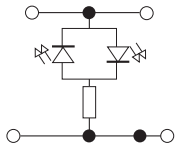

RT/SU4-2L-LD

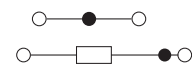

RT/SU4-2L-R1

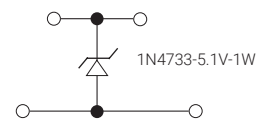

RT/SU4-2L-DZ3

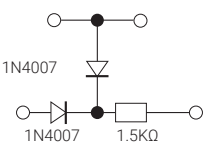

RT/SU2.5/4-2L-DR2

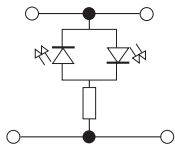

RT/SU2.5/4-2L-LD

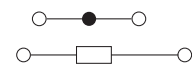

RT/SU2.5/4-2L-R1

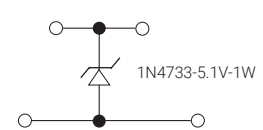

RT/SU2.5/4-2L-DZ3

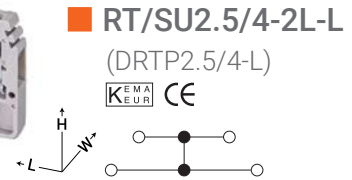
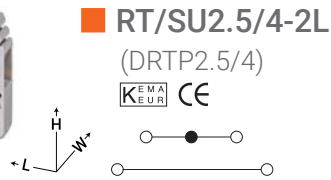

IEC 60947-7-1 rated data	RT/SU2.5/4-2L	RT/SU2.5/4-2L-L
Voltage(V)/Impulse voltage (kV)	500 / 6	500 / 6
Pollution degree/Voltage category /Material group	3/III/I	3/III/I
Current (A)	32	32
Cross-section (mm <sup>2</sup> )	4	4

Description	Type	Ordering No.	Qty.	Type	Ordering No.	Qty.
Terminal block, for mounting on TH 35-7.5, 15	RT/SU2.5/4-2L	6010728005	50	RT/SU2.5/4-2L-L	6010729005	50
End plate Width (mm)	EP-DRTP2.5/4 1.2	6020203001	20	EP-DRTP2.5/4 1.2	6020203001	20
Partition width (mm)	GP 3	6020305005	20	GP 3	6020305005	20
End bracket, for TH 35-7.5, 15 width (mm)	EB/3 10	6020101003	50	EB/3 10	6020101003	50
End bracket for mounting on G 32 TH35-7.5,15 Width (mm)	EB/2 10	6020101002	50	EB/2 10	6020101002	50
Cross-connection	CC10-2.5 10-pos. CC3-2.5 3-pos. CC2-2.5 2-pos.	6020502009 6020502002 6020502001	10 50 50	-	-	-
max. current (A)	24					
Bridge-comb	BC 10-2.5 10-pos. BC 3-2.5 3-pos. BC 2-2.5 2-pos.	6020504009 6020504002 6020504001	10 50 50	BC 10-2.5 10-pos. BC 3-2.5 3-pos. BC 2-2.5 2-pos.	6020504009 6020504002 6020504001	10 50 50
max. current (A)	24					
Test Socket	TS3/6/2.3	6020402001	50	-	-	-
Screw Driver	0.5X3	-	-	0.5X3	-	-
Marking Tags	NS6	For details see Accessories		NS6	For details see Accessories	
Marking Holder	Marking Holder	6032100001	10	Marking Holder	6032100001	10
Strip Lable	TBSL 22x20	For details see Accessories		TBSL 22x20	For details see Accessories	
Color						
<b>Dimensions (mm)</b>	<b>W / L / H</b>			<b>W / L / H</b>		
Width/Length/Height, TH 35-7.5	6/57.5/57.5			6/57.5/57.5		
Width/Length/Height, TH 35-15	6/57.5/65			6/57.5/65		
<b>Connection capacity</b>						
Rigid Solid (mm <sup>2</sup> )	0.5-4			0.5-4		
Rigid stranded (mm <sup>2</sup> )	0.5-4			0.5-4		
Flexible (mm <sup>2</sup> )	0.5-4			0.5-4		
American Wire Gauge (AWG)	20-12			20-12		
<b>IEC test gauge</b>	<b>A4</b>			<b>A4</b>		
Stripping length (mm)	9			9		
<b>Clamping screw</b>	<b>M2.5</b>			<b>M2.5</b>		
Tightening torque (N.m)	0.4			0.4		
<b>Insulation material</b>	<b>PA</b>			<b>PA</b>		



### RT/SU4-2L

(DRTP4)

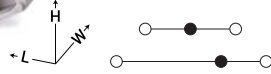

### RT/SU4-3L

(TRTP4)

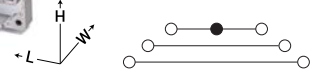

IEC 60947-7-1 rated data	RT/SU2.5-2L	RT/SU4-3L
Voltage(V)/Impulse voltage (kV)	500 / 6	400 / 6
Pollution degree/Voltage category/Material group	3/III/I	3/III/I
Current (A)	32	32
Cross-section (mm <sup>2</sup> )	4	4

Description	Type	Ordering No.	Qty.	Type	Ordering No.	Qty.
Terminal block, for mounting on TH 35-7.5, 15	RT/SU4-2L	60107010	50	RT/SU4-3L	6010750005	25
End plate 1 width (mm)	EP1-DRTP4 1.5	6020203002	20	-	-	-
End plate 2 width (mm)	EP2-DRTP4 1.5	6020203003	20	-	-	-
End plate 3 width (mm)	EP3-DRTP4 2.5	6020203004	20	-	-	-
Partition width (mm)	P-DRTP4 2.5	6020302001	20	-	-	-
Partition width (mm)	-	-	-	GP 3	6020305005	20
Small partition no loss of pitch	SP-D4	6020304004	100	-	-	-
End bracket for G32 TH TH35-7.5,15 width (mm)	EB/2 10	6020101002	50	EB/2 10	6020101002	50
Cross-connection	CC10-D4 10-pos. 6020503009 CC3-D4 3-pos. 6020503002 CC2-D4 2-pos. 6020503001	10 10 50	10 10 50	CC10-D4 10-pos. 6020503009 CC3-D4 3-pos. 6020503002 CC2-D4 2-pos. 6020503001	10 10 50	10 10 50
max. current (A)	32			32		
Bridge-comb	BC10-4 10-pos. 6020504109 BC3-4 3-pos. 6020504102 BC2-4 2-pos. 6020504101	10 50 50	10 50 50	BC10-4 10-pos. 6020504109 BC3-4 3-pos. 6020504102 BC2-4 2-pos. 6020504101	10 50 50	10 50 50
max. current (A)	32			32		
Test Socket	TS3/6/2.3	6020402001	50	TS3/6/2.3	6020402001	50
Screw Driver	0.5X3	-	-	0.5X3	-	-
Marking Tags	NS6.4	For details see Accessories		NS6.4	For details see Accessories	
Marking Holder	Marking Holder	6032100001	10	Marking Holder	6032100001	10
Strip Lable	TBSL 22x20	For details see Accessories		TBSL 22x20	For details see Accessories	
Color (Color Code is the last 2 digits of the Ordering No.)						
<b>Dimensions (mm)</b>	<b>W / L / H</b>			<b>W / L / H</b>		
Width/Length/Height, TH 35-7.5	6.4/68.5/67.5			6.4/78.5/68		
Width/Length/Height, TH 35-15	6.4/68.5/75			6.4/78.5/75.5		
<b>Connection capacity</b>						
Rigid Solid (mm <sup>2</sup> )	0.5-4			0.5-4		
Rigid stranded (mm <sup>2</sup> )	0.5-4			0.5-4		
Flexible (mm <sup>2</sup> )	0.5-4			0.5-4		
American Wire Gauge (AWG)	20-12			20-12		
<b>IEC test gauge</b>	<b>A4</b>			<b>A4</b>		
Stripping length (mm)	9			9		
<b>Clamping screw</b>	<b>M2.5</b>			<b>M2.5</b>		
Tightening torque (N.m)	0.4			0.4-0.6		
<b>Insulation material</b>	<b>PA</b>			<b>PA</b>		

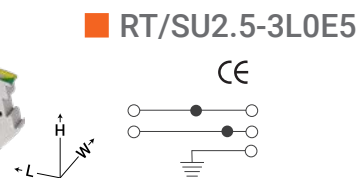
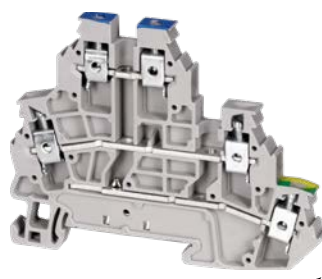
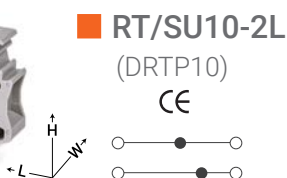

IEC 60947-7-1 rated data	RT/SU10-2L	RT/SU2.5-3LOE5
Voltage(V)/Impulse voltage (kV)	800 / 8	400 / 6
Pollution degree/Voltage category /Material group	3/III/I	3/III/I
Current (A)	57	24
Cross-section (mm <sup>2</sup> )	10	2.5

Description	Type	Ordering No.	Qty.	Type	Ordering No.	Qty.
Terminal block, for mounting on TH 35-7.5, 15	RT/SU10-2L	6010740005	25	RT/SU2.5-3LOE5	6010603001	35
End plate	EP- RT/SU10-2L	6020203020	20	EP-RT/SU2.5-3LOE5	6020206002	20
Width (mm)	1.2			1		
End bracket for G32 TH 35-15 width (mm)	EB/2 10	6020101002	50	EB/2 10	6020101002	50
Cross-connection	CC10-10 10-pos. CC3-10 3-pos. CC2-10 2-pos. 57	6020502309 6020502302 6020502301	10 50 50	CC10-2.5 10-pos. CC3-2.5 3-pos. CC2-2.5 2-pos. 24	6020503009 6020503002 6020503001	- - -
max. current (A)						
Bridge-comb	-	-	-	BC 10-2.5 10-pos. BC 3-2.5 3-pos. BC 2-2.5 2-pos. 24	6020504009 6020504002 6020504001	10 50 50
max. current (A)						
Test Socket	TS3/8/4	6020402002	50	TS3/6/2.3	-	-
Screw Driver	1.0*4.0	-	-	0.5X3	-	-
Marking Tags	NS10	For details see Accessories		NS6	For details see Accessories	
Marking Holder	Marking Holder	6032100001	10	Marking Holder	6032100001	10
Strip Lable	TBSL 22x20	For details see Accessories		TBSL 22x20	For details see Accessories	
Color						
<b>Dimensions (mm)</b>	<b>W / L / H</b>			<b>W / L / H</b>		
Width/Length/Height, TH 35-7.5	10/87/73.5			6/82.5/64.5		
Width/Length/Height, TH 35-15	10/87/81			6/82.5/72		
<b>Connection capacity</b>						
Rigid Solid (mm <sup>2</sup> )	0.5-16			0.5-4		
Rigid stranded (mm <sup>2</sup> )	0.5-16			0.5-4		
Flexible (mm <sup>2</sup> )	0.5-10			0.5-2.5		
American Wire Gauge (AWG)	20-6			20-12		
<b>IEC test gauge</b>	<b>B6</b>			<b>A4</b>		
Stripping length (mm)	12			9		
<b>Clamping screw</b>	<b>M4</b>			<b>M2.5</b>		
Tightening torque (N.m)	1.5-1.8			0.5-0.6		
<b>Insulation material</b>	<b>PA</b>			<b>PA</b>		



**RAAD**  <sup>®</sup> Electrical Connection for  
Technological Components  
*Confidence in Connection*

# Test Disconnect Terminal Blocks

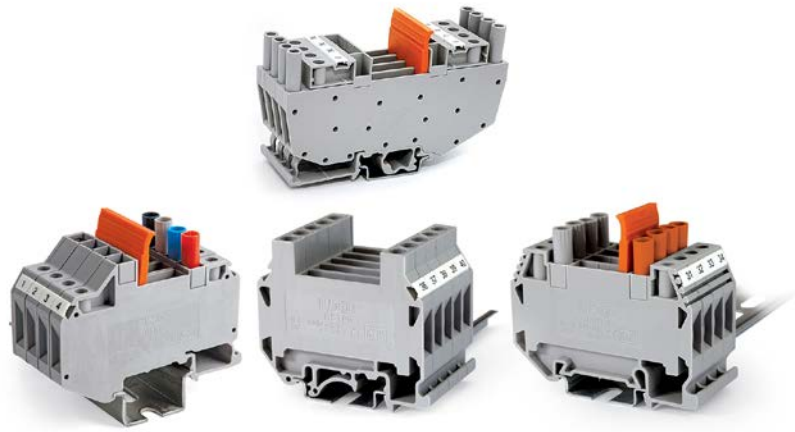

RAAD test disconnect terminal blocks are used in measuring, control and remote-controlled systems.

RT/ST6 series accompanied by their relating accessories, can be mounted in all types of circuits specified in this field, including secondary circuits for current transformers.

The following electrical circuits show examples of the application of RT/ST6 series products in the electrical industry.

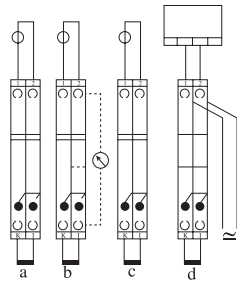

Simple current transformer test circuit:  
 a= Normal operation  
 b= Measured value testing  
 c= Transformer testing  
 d= Relay testing

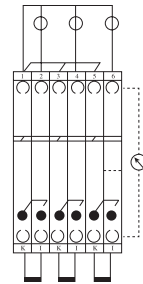

Three-phase transducer test set

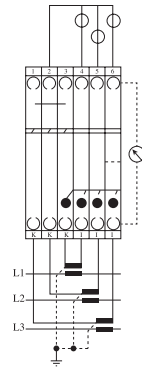

Three-phase linked transducer test set

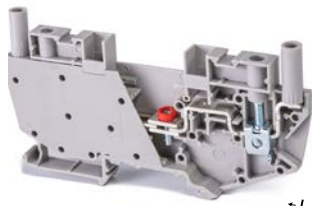

**RT/ST6**  
(RST6)  
KEMA  
CE

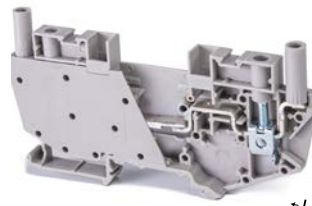

**RT/ST6-L**  
(RTT6)  
CE

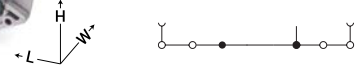

IEC 60947-7-1 rated data	RT/ST6			RT/ST6-L		
Voltage (V)	400			400		
Impulse voltage (kV)	6			6		
Pollution degree/Voltage category/Material group	3/III/1			3/III/1		
Current (A)	41			41		
Cross-section (mm <sup>2</sup> )	6			6		
Description	Type	Ordering No.	Qty.	Type	Ordering No.	Qty.
Terminal block, for mounting on TH 35-7.5, 15	RT/ST6	6010301001	20	RT/ST6-L	6010305001	20
End bracket, for TH 35-7.5, 15 width (mm)	EB/4			EB/4		
	8	6020101006	50	8	6020101006	50
	EB/3			EB/3		
	10	6020101003	50	10	6020101003	50
	EB/1			EB/1		
	9.5	6020101001	50	9.5	6020101001	50
Moveable cross-connection, for 2,3,4,6,10 terminal blocks, with 2,3,4,6,10 screws	ML10N 10-pos.	6020602005	10	ML10N 10-pos.	6020602005	10
	ML6N 6-pos.	6020602004	10	ML6N 6-pos.	6020602004	10
	ML4N 4-pos.	6020602003	50	ML4N 4-pos.	6020602003	50
	ML3N 3-pos.	6020602002	50	ML3N 3-pos.	6020602002	50
	ML2N 2-pos.	6020602001	50	ML2N 2-pos.	6020602001	50
max. current (A)	32			32		
Cross-connection	CC10-6 10-pos.	6020502209	10	CC10-6 10-pos.	6020502209	10
	CC3-6 3-pos.	6020502202	50	CC3-6 3-pos.	6020502202	50
	CC2-6 2-pos.	6020502201	50	CC2-6 2-pos.	6020502201	50
max. current (A)	41			41		
Bridge-comb	JEB10-6 10-pos.	6020506009	10	JEB10-6 10-pos.	6020506009	10
	JEB3-6 3-pos.	6020506002	50	JEB3-6 3-pos.	6020506002	50
	JEB2-6 2-pos.	6020506001	50	JEB2-6 2-pos.	6020506001	50
max. current (A)	41			41		
Test Socket	TS6	6020401005	50	TS6	6020401005	50
Screw Driver	0.6x3.5 0.5x3	-	-	0.6x3.5 -	-	-
Marking Tags	NS8	For details see Accessories		NS8	For details see Accessories	
Marking Holder	Marking Holder	6032100001	10	Marking Holder	6032100001	10
Strip Lable	TBSL 22x20	For details see Accessories		TBSL 22x20	For details see Accessories	
Color						
Dimensions (mm)	W / L / H			W / L / H		
Width/Length/Height, TH 35-7.5	8/107/64			8/107/64		
Width/Length/Height, TH 35-15	8/107/71.5			8/107/71.5		
Connection capacity						
Rigid Solid (mm <sup>2</sup> )	0.5-10			0.5-10		
Rigid stranded (mm <sup>2</sup> )	0.5-10			0.5-10		
Flexible (mm <sup>2</sup> )	0.5-6			0.5-6		
American Wire Gauge (AWG)	20-8			20-8		
IEC test gauge	A5			A5		
Stripping length (mm)	12			12		
Clamping screw/Tightening torque (N.m)	M3.5 / 1.2			M3.5 / 1.2		
Center screw/Tightening torque (N.m)	M3 / 0.5			-		
Insulation material	PA			PA		

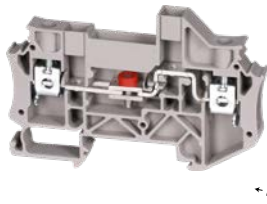

### RT/ST6-SHT

(RSTT6)

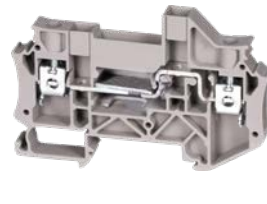

### RT/ST6-SHT-L

(RSTU6)

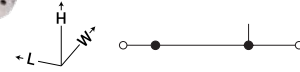

IEC 60947-7-1 rated data	RT/ST6-SHT			RT/ST6-SHT-L		
Voltage (V)	400			400		
Impulse voltage (kV)	6			6		
Pollution degree/Voltage category/Material group	3/III/I			3/III/I		
Current (A)	41			41		
Cross-section (mm <sup>2</sup> )	6			6		
Description	Type	Ordering No.	Qty.	Type	Ordering No.	Qty.
Terminal block, for mounting on TH 35-7.5, 15	RT/ST6-SHT	6010303001	25	RT/ST6-SHT-L	6010305001	25
End Plate width (mm)	EP-RSTT6 1.5	6020201003	50	EP-RSTT6 1.5	6020201003	50
End bracket, for TH 35-7.5, 15 width (mm)	EB/4 8 EB/3 10 EB/1 9.5	6020101006 6020101003 6020101001	50 50 50	EB/4 8 EB/3 10 EB/1 9.5	6020101006 6020101003 6020101001	50 50 50
Moveable cross-connection, for 2,3,4,6,10 terminal blocks, with 2,3,4,6,10 screws	ML10N 10-pos. ML6N 6-pos. ML4N 4-pos. ML3N 3-pos. ML2N 2-pos.	6020602005 6020602004 6020602003 6020602002 6020602001	10 10 50 50 50	ML10N 10-pos. ML6N 6-pos. ML4N 4-pos. ML3N 3-pos. ML2N 2-pos.	6020602005 6020602004 6020602003 6020602002 6020602001	10 10 50 50 50
max. current (A)	32			32		
Cross-connection	CC10-6 10-pos. CC3-6 3-pos. CC2-6 2-pos.	6020502209 6020502202 6020502201	10 50 50	CC10-6 10-pos. CC3-6 3-pos. CC2-6 2-pos.	6020502209 6020502202 6020502201	10 50 50
max. current (A)	41			41		
Bridge-comb	JEB10-6 10-pos. JEB3-6 3-pos. JEB2-6 2-pos.	6020506009 6020506002 6020506001	10 50 50	JEB10-6 10-pos. JEB3-6 3-pos. JEB2-6 2-pos.	6020506009 6020506002 6020506001	10 50 50
max. current (A)	41			41		
Test Socket	TS6	6020401005	50	TS6	6020401005	50
Screw Driver	0.6x3.5 0.5x3	-	-	0.6x3.5 -	-	-
Marking Tags	NS8	For details see Accessories		NS8	For details see Accessories	
Marking Holder	Marking Holder	6032100001	10	Marking Holder	6032100001	10
Strip Lable	TBSL 22x20	For details see Accessories		TBSL 22x20	For details see Accessories	
Color						
Dimensions (mm)	W / L / H			W / L / H		
Width/Length/Height, TH 35-7.5	8/81/56			8/81/56		
Width/Length/Height, TH 35-15	8/81/63.5			8/81/63.5		
Connection capacity						
Rigid Solid (mm <sup>2</sup> )	0.5-10			0.5-10		
Rigid stranded (mm <sup>2</sup> )	0.5-10			0.5-10		
Flexible (mm <sup>2</sup> )	0.5-6			0.5-6		
American Wire Gauge (AWG)	20-8			20-8		
IEC test gauge	A5			A5		
Stripping length (mm)	12			12		
Clamping screw/Tightening torque (N.m)	M3.5 / 1.2			M3.5 / 1.2		
Center screw/Tightening torque (N.m)	M3 / 0.5			-		
Insulation material	PA			PA		





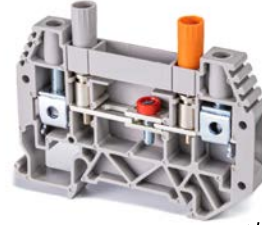
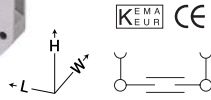





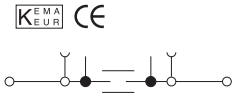





RT/SP6

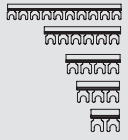

RT/ST6-CMP

(RSTN6)



IEC 60947-7-1 rated data	RSTP6			RT/ST6-CMP		
Voltage (V)	500			400		
Impulse voltage (kV)	6			6		
Pollution degree/Voltage category/Material group	3/III/I			3/III/I		
Current (A)	41			41		
Cross-section (mm <sup>2</sup> )	6			6		
Description	Type	Ordering No.	Qty.	Type	Ordering No.	Qty.
Terminal block, for mounting on G 32  TH 35-7.5, 15 	RSTP6	6010301001	25	RT/ST6-CMP	6010306001	25
End Plate 	EP-RSTP6	6020201004	50	-	-	-
width (mm)	1.5					
End Plate 	-	-	-	EP-RSTN6 1.5	6020201006	50
width (mm)						
End bracket, for TH 35-7.5, 15 	 EB/4 8	6020101006	50	EB/4 8	6020101006	50
width (mm)	EB/3 10	6020101003	50	EB/3 10	6020101003	50
	EB/1 9.5	6020101001	50	EB/1 9.5	6020101001	50
Moveable cross-connection, for 2,3,4,6,10 terminal blocks, with 2,3,4,6,10 screws 	-	-	-	L10 10-pos. L6 6-pos. L4 4-pos. L3 3-pos. L2 2-pos.	6020501005 6020501004 6020501003 6020501002 6020501001	10 10 50 50 50
max. current (A)				41		
Cross-connection 	-	-	-	CC10-6 10-pos. CC3-6 3-pos. CC2-6 2-pos.	6020502209 6020502202 6020502201	10 50 50
max. current (A)				41		
Bridge-comb 	JEB10-6 10-pos. JEB3-6 3-pos. JEB2-6 2-pos.	6020506009 6020506002 6020506001	10 50 50	JEB10-6 10-pos. JEB3-6 3-pos. JEB2-6 2-pos.	6020506009 6020506002 6020506001	10 50 50
max. current (A)	41			41		
Test Socket 	-	-	-	TS3-26-4	6020401100	50
Screw Driver 	1.0 x 5.5	-	-	0.6 x 3.5 0.5 x 3	-	-
Marking Tags 	NS8	For details see Accessories		NS8	For details see Accessories	
Marking Holder 	Marking Holder	6032100001	10	Marking Holder	6032100001	10
Strip Lable 	TBSL 22x20	For details see Accessories		TBSL 22x20	For details see Accessories	
Color 						
Dimensions (mm)	W / L / H			W / L / H		
Width/Length/Height, TH 35-7.5	8 / 63 / 54.8			8 / 70.2 / 50		
Width/Length/Height, TH 35-15	8/63/55			8/70.2/50.5		
Width/Length/Height, G32	8/63/62.5			8/70.2/58		
Connection capacity						
Rigid Solid (mm <sup>2</sup> )/ Rigid stranded (mm <sup>2</sup> )	0.5-10			0.5-10		
Flexible (mm <sup>2</sup> )	0.5-6			0.5-6		
American Wire Gauge (AWG)	20-8			20-8		
IEC test gauge	A5			A5		
Stripping length (mm)	12			12		
Clamping screw/Tightening torque (N.m)	M3.5/1.2			M3.5/1.2		
Center screw/Tightening torque (N.m)	M3/0.5			M3/0.5		
Insulation material	PA			PA		

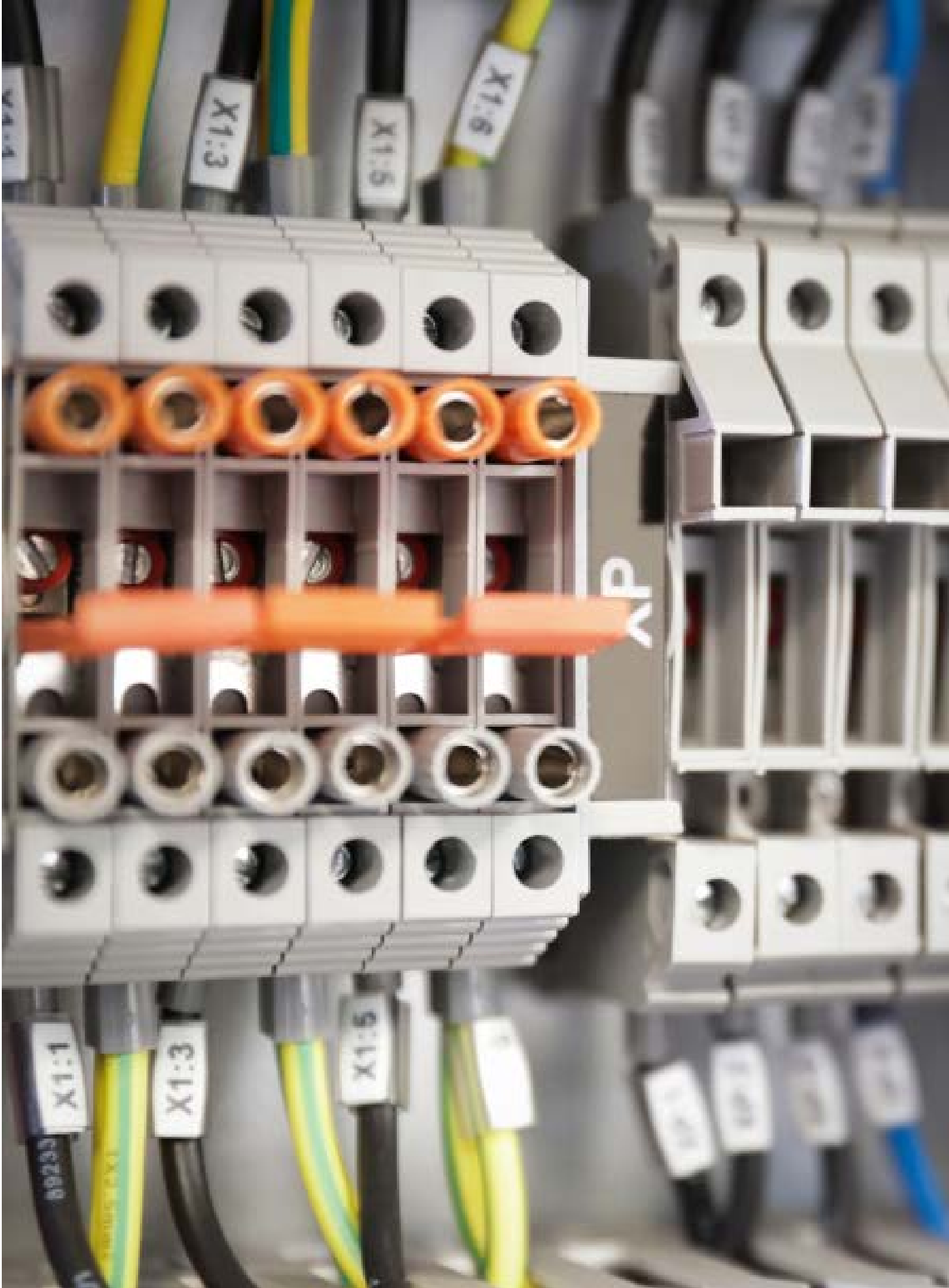



**RAAD**  <sup>®</sup> Electrical Connection for  
Technological Components

*Confidence in Connection*

# Disconnect & Component Terminal Blocks



RAAD disconnect and component terminal blocks can be used in measurement and control systems. The characteristics of the RT/SK2.5 series are described below:

- The RT/SK2.5 series can quickly and safely disconnect the current path for safe maintenance.
- RT/SK2.5-TS is characterized by a test socket used for measuring and monitoring circuits.
- In addition to switching the circuits, RT/SK2.5-D can be used as a diode terminal block, and RT/SK2.5-R can be used as a resistor terminal block.
- According to customer requirements, RT/SK2.5 has the capability of mounting any other components such as a resistor, a capacitor, and etc.



### RT/SK2.5

(RDT2.5-C)

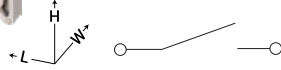

### RT/SK2.5-TS

(RDT2.5-CTS)

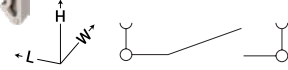

IEC 60947-7-1 rated data	RT/SK2.5	RT/SK2.5-TS
Voltage (V)	500	500
Impulse voltage (kV)	6	6
Pollution degree/Voltage category/Material group	3/III/1	3/III/1
Current (A)	17.5	17.5
Cross-section (mm <sup>2</sup> )	2.5	2.5
Max current (A)	20	20

Description	Type	Ordering No.	Qty.	Type	Ordering No.	Qty.
Terminal block, for mounting on TH 35-7.5, 15	RT/SK2.5	60108010	50	RT/SK2.5-TS With test socket screw	60108010	50
End plate	EP-RTP2.5H-10 1.2	6020202105	100	EP-RTP2.5H-10 1.2	6020202105	50
Width (mm)						
End bracket, for TH 35-7.5, 15 width (mm)	EB/4 8 EB/3 10 EB/1 9.5	6020101006 6020101003 6020101001	50 50 50	EB/4 8 EB/3 10 EB/1 9.5	6020101006 6020101003 6020101001	50 50 50
Bridge-comb	BC 10-2.5 10-pos. BC 3-2.5 3-pos. BC 2-2.5 2-pos.	6020504009 6020504002 6020504001	10 50 50	BC 10-2.5 10-pos. BC 3-2.5 3-pos. BC 2-2.5 2-pos.	6020504009 6020504002 6020504001	10 50 50
Screw Driver	0.5x3	-	-	0.5x3	-	-
Marking Tags	NS6	For details see Accessories		NS6	For details see Accessories	
Marking Holder	Marking Holder	6032100001	10	Marking Holder	6032100001	10
Strip Lable	TBSL 22x20	For details see Accessories		TBSL 22x20	For details see Accessories	
Color (Color Code is the last 2 digits of the Ordering No.)						
<b>Dimensions (mm)</b>	<b>W / L / H</b>			<b>W / L / H</b>		
Width/Length/Height, TH 35-7.5	6/45.2/48			6/45.2/48		
Width/Length/Height, TH 35-15	6/45.2/55.5			6/45.2/55.5		
<b>Connection capacity</b>						
Rigid Solid (mm <sup>2</sup> )	0.5-4			0.5-4		
Rigid stranded (mm <sup>2</sup> )	0.5-4			0.5-4		
Flexible (mm <sup>2</sup> )	0.5-4			0.5-4		
American Wire Gauge (AWG)	20-12			20-12		
<b>IEC test gauge</b>	<b>A4</b>			<b>A4</b>		
Stripping length (mm)	12			12		
<b>Clamping screw</b>	<b>M2.5</b>			<b>M2.5</b>		



**RT/SK2.5-D**  
(RDT2.5-CDC)

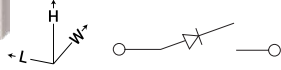

**RT/SK2.5-R**  
(RDT2.5-CRC)

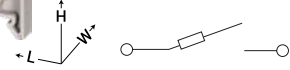

IEC 60947-7-1 rated data	RT/SK2.5-D	RT/SK2.5-R
Voltage (V)	500	500
Impulse voltage (kV)	6	6
Diode reverse voltage (V)	1000	-
Current (A)	1*	17.5**
Diode	1N4007	-
Cross-section (mm <sup>2</sup> )	2.5	2.5

Description	Type	Ordering No.	Qty.	Type	Ordering No.	Qty.
Terminal block, for mounting on TH 35-7.5, 15	RT/SK2.5-D	6010801002	25	RT/SK2.5-R	6010801007	25
End plate	EP-RTP2.5H-10 1.2	6020202105	100	EP-RTP2.5H-10 1.2	6020202105	50
Width (mm)						
End bracket, for TH 35-7.5, 15 width (mm)	EB/2 10	6020101002	50	EB/2 10	6020101002	50
Bridge-comb	BC 10-2.5 10-pos. BC 3-2.5 3-pos. BC 2-2.5 2-pos.	6020504009 6020504002 6020504001	10 50 50	BC 10-2.5 10-pos. BC 3-2.5 3-pos. BC 2-2.5 2-pos.	6020504009 6020504002 6020504001	10 50 50
Screw Driver	0.5x3	-	-	0.5x3	-	-
Marking Tags	NS6	For details see Accessories		NS6	For details see Accessories	
Marking Holder	Marking Holder	6032100001	10	Marking Holder	6032100001	10
Strip Lable	TBSL 22x20	For details see Accessories		TBSL 22x20	For details see Accessories	
Color						
<b>Dimensions (mm)</b>	<b>W / L / H</b>			<b>W / L / H</b>		
Width/Length/Height, TH 35-7.5	6/45.2/67.5			6/45.2/67.5		
Width/Length/Height, TH 35-15	6/45.2/75			6/45.2/75		
<b>Connection capacity</b>						
Rigid Solid (mm <sup>2</sup> )	0.5-4			0.5-4		
Rigid stranded (mm <sup>2</sup> )	0.5-4			0.5-4		
Flexible (mm <sup>2</sup> )	0.5-4			0.5-4		
American Wire Gauge (AWG)	20-12			20-12		
<b>IEC test gauge</b>	<b>A4</b>			<b>A4</b>		
Stripping length (mm)	12			12		
<b>Clamping screw</b>	<b>M2.5</b>			<b>M2.5</b>		
Tightening torque (N.m)	0.4-0.6			0.4-0.6		



**RAAD**  <sup>®</sup> Electrical Connection for  
Technological Components  
*Confidence in Connection*

# Fuse Terminal Blocks

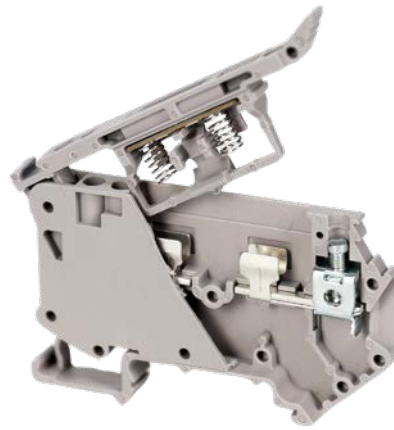

All electrical control systems and machines must be protected with fuse cartridges, thus fuse terminal blocks have been developed to meet some requirements.

RAAD fuse terminals are available in two types, RT/SF4 and RT/SK2.5-F, which have the following characteristics:

- RT/SF4 with base terminal block and top hinge type fuse carrier performs the function of protecting electrical systems with fuses.
- The RT/SF4-LD is equipped with a light indicator that signalizes when the fuse blows.
- The terminal type RT/SK2.5-F (and RT/SK2.5-FLD) has the advantage of easily removing and replacing the cap (and the fuse) as well as isolation of the fuse signal circuit from the terminal block base when detaching the cap.
- The below table shows the maximum power dissipation of different fuse terminal blocks at 23°C according to IEC 60947-7-3:

Type	Overload & short circuit protection		Exclusive short circuit protection	
	Separate	Compound	Separate	Compound
RT/SF4	1.6 watt	1.6 watt	4 watt	1.6 watt
RT/SK2.5-F	2.5 watt	1.6 watt	4 watt	2.5 watt



### RT/SF4

(RFT5)

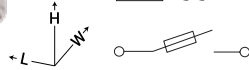

### RT/SF4-LD

(RFT5-LD)

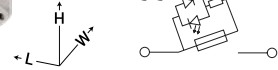

IEC 60947-7-3 rated data	RT/SF4	RT/SF4-LD
Voltage (V)	800	-
Impulse voltage (kV)	8	-
Pollution degree/ Voltage category/Material group	3/III/1	3/III/1
Current (A)	6.3	6.3
Cross-section (mm <sup>2</sup> )	4	4

Description	Type	Ordering No.	Qty.	Type	Ordering No.	Qty.
Terminal block, for mounting on TH 35-7.5, 15	RT/SF4	60102010	25	RT/SF4-LD 24,48VAC/DC*	60102020	25
				110,220 VAC/DC*	60102020	25
End bracket, for TH 35-7.5, 15 width (mm)	EB/4 8	6020101006	50	EB/4 8	6020101006	50
	EB/3 10	6020101003	50	EB/3 10	6020101003	50
	EB/1 9.5	6020101001	50	EB/1 9.5	6020101001	50
Bridge-comb	JEB10-6 10-pos.	6020506009	10	JEB10-6 10-pos.	6020506009	10
	JEB3-6 3-pos.	6020506002	50	JEB3-6 3-pos.	6020506002	50
	JEB2-6 2-pos.	6020506001	50	JEB2-6 2-pos.	6020506001	50
max. current (A)	41			41		
Screw Driver	0.5x3	-	-	0.5x3	-	-
Marking Tags	NS8	For details see Accessories		NS8	For details see Accessories	
Marking Holder	Marking Holder	6032100001	10	Marking Holder	6032100001	10
Strip Lable	TBSL 22x20	For details see Accessories		TBSL 22x20	For details see Accessories	
Color (Color Code is the last 2 digits of the Ordering No.)						

Dimensions (mm)	W / L / H	W / L / H
Width/Length/Height, TH 35-7.5	8/76.5/56	8/76.5/56
Width/Length/Height, TH 35-15	8/76.5/63.5	8/76.5/63.5
Connection capacity		
Rigid Solid (mm <sup>2</sup> )	0.5-4	0.5-4
Rigid stranded (mm <sup>2</sup> )	0.5-4	0.5-4
Flexible (mm <sup>2</sup> )	0.5-4	0.5-4
American Wire Gauge (AWG)	20-12	20-12
IEC test gauge		
	A4	A4
Stripping length (mm)	12	12
Clamping screw		
	M3	M3
Tightening torque (N.m)	0.5	0.5
Insulation material		
	PA	PA

\* Other voltages available Upon request



### RT/SK2.5-F

(RDT2.5-CFC)

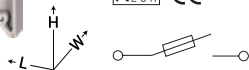

### RT/SK2.5-FLD

(RDT2.5-CFCLD)

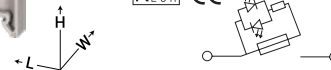

IEC 60947-7-3 rated data	RT/SK2.5-F	RT/SK2.5-FLD
Voltage (V)	500	-
Impulse voltage (kV)	6	-
Pollution degree/Voltage category/Material group	3/III/I	3/III/I
Current (A)	6.3	6.3
Cross-section (mm <sup>2</sup> )	2.5	2.5

Description	Type	Ordering No.	Qty.	Type	Ordering No.	Qty.
Terminal block, for mounting on TH 35-7.5, 15	RT/SK2.5-F	60108010	25	RT/SK2.5-FLD 24,48 VAC/DC* 110,220 VAC/DC*	6010801004 6010801005	25 25
End plate	EP-RTP2.5H-10 1.2	6020202105	100	EP-RTP2.5H-10 1.2	6020202105	50
Width (mm)						
End bracket, for TH 35-7.5, 15 width (mm)	EB/2 10	6020101002	50	EB/2 10	6020101002	50
Bridge-comb	BC 10-2.5 10-pos. BC 3-2.5 3-pos. BC 2-2.5 2-pos.	6020504009 6020504002 6020504001	10 50 50	BC 10-2.5 10-pos. BC 3-2.5 3-pos. BC 2-2.5 2-pos.	6020504009 6020504002 6020504001	10 50 50
Screw Driver	0.5x3	-	-	0.5x3	-	-
Marking Tags	NS6	For details see Accessories		NS6	For details see Accessories	
Marking Holder	Marking Holder	6032100001	10	Marking Holder	6032100001	10
Strip Lable	TBSL 22x20	For details see Accessories		TBSL 22x20	For details see Accessories	
Color (Color Code is the last 2 digits of the Ordering No.)	03   17			Type 04   18 24,48 VAC/DC 05   19 110,220 VAC/DC		
<b>Dimensions (mm)</b>	<b>W / L / H</b>			<b>W / L / H</b>		
Width/Length/Height, TH 35-7.5	6/45.2/67.5			6/45.2/67.5		
Width/Length/Height, TH 35-15	6/45.2/75			6/45.2/75		
<b>Connection capacity</b>						
Rigid Solid (mm <sup>2</sup> )	0.5-4			0.5-4		
Rigid stranded (mm <sup>2</sup> )	0.5-4			0.5-4		
Flexible (mm <sup>2</sup> )	0.5-4			0.5-4		
American Wire Gauge (AWG)	20-12			20-12		
<b>IEC test gauge</b>	<b>A4</b>			<b>A4</b>		
Stripping length (mm)	12			12		
<b>Clamping screw</b>	<b>M2.5</b>			<b>M2.5</b>		



RT/SF4-2L

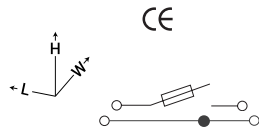

RT/SF4-2L-LD

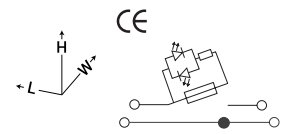

IEC 60947-7-1 rated data IEC 60947-7-3	RT/SF4-2L	RT/SF4-2L-LD
Voltage (V)/Impulse voltage(kV)	500/6	-
Pollution degree/Voltage category/Material group	3/III/1	3/III/1
Above level current/ Below level current (A)	6.3/32	6.3/32
Maximum conductor cross-section (mm <sup>2</sup> )	6	6
Cross-section (mm <sup>2</sup> )	4	4

Description	Type	Ordering No.	Qty.	Type	Ordering No.	Qty.
Terminal block, for mounting on TH 35-7.5, 15	RT/SF4-2L	6010204001	20	RT/SF4-2L-LD 24,48 VAC/DC 110,220 VAC/DC	6010204002 6010204003	20
End plate	EP-RT/SF4-2L	6020207001	20	EP-RT/SF4-2L	6020207001	20
Width (mm)	1.2			1.2		
Partition width (mm)	GP 3	6020305005	20	GP 3	6020305005	20
End bracket, for TH 35-7.5, 15 width (mm)	EB/4 8	6020101006	50	EB/4 8	6020101006	50
	EB/3 10	6020101003	50	EB/3 10	6020101003	50
	EB/2 10	6020101002	50	EB/2 10	6020101002	50
	EB/1 9.5	6020101001	50	EB/1 9.5	6020101001	50
Bridge screwless	BS10-6 10-pos. BS3-6 3-pos. BS2-6 2-pos.	6020505109 6020505102 6020505101	20 20 20	BS10-6 10-pos. BS3-6 3-pos. BS2-6 2-pos.	6020505109 6020505102 6020505101	20 20 20
max. current (A)	41			41		
Bridge-comb	JEB10-6 JEB3-6 JEB2-6	6020506009 6020506002 6020506001	20 20 20	JEB10-6 JEB3-6 JEB2-6	6020506009 6020506002 6020506001	20 20 20
max. current (A)	41			41		
Screw Driver	0.5x3.0	-	-	0.5x3.0	-	-
Marking Tags	NS8	For details see Accessories		NS8	For details see Accessories	
Strip Lable	TBSL 22x20	For details see Accessories		TBSL 22x20	For details see Accessories	
Color						

Dimensions (mm)	W / L / H	W / L / H
Width/Length/Height, TH 35-7.5	8/72.4/64.3	8/72.4/64.3
Width/Length/Height, TH 35-15	8/72.4/71.8	8/72.4/71.8
Connection capacity		
Rigid Solid (mm <sup>2</sup> )	0.5-6	0.5-6
Rigid stranded (mm <sup>2</sup> )	0.5-6	0.5-6
Flexible (mm <sup>2</sup> )	0.5-4	0.5-4
American Wire Gauge (AWG)	20-10	20-10
IEC test gauge	A4	A4
Stripping length (mm)	10	10
Clamping screw	M2.6	M2.6
Tightening torque (N.m)	0.6	0.6
Insulation material	PA	PA





**RAAD**  <sup>®</sup> Electrical Connection for  
Technological Components  
*Confidence in Connection*



## Screw Connections

This is the most popular of all known methods of connection. No other connection method allows such high contact forces to be produced in such a small space as a screw. RAAD terminal block screw connection is easy to operate with a standard screwdriver, suitable for all types of conductors without special preparation, absolutely gas tight and vibration proof.

## Reliable Clamping

Most RAAD products use a clamping unit system which has been proven millions of times, world-wide. The clamping units as well as clamping screws are produced from hardened steel. When the clamping screw is tightened, the resultant force causes the upper thread overlap to spring open, thus causing a locking action to be exerted on the screw and an excellent resistance against vibration is achieved.

## RT/SG series:

The RT/SG series is a terminal with a screw clamping structure, and it uses a push-type bridge, which has the following advantages:

- Space-saving design, optimizing handling and easy assembling
- High assembly speed due to use of the push-type bridge
- The ability to connect unlimited terminal blocks to each other through two row push-type bridge
- Easy and strong snap on connection to TH35 rails
- Body compatibility in all ranges
- Comply with a comprehensive range of accessories, marking and bridging
- Made of PA insulating material



**RT/SG2.5**  
(RTX2.5)

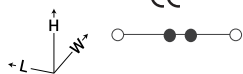

**RT/SG4**  
(RTX4)

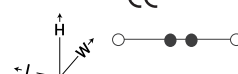

IEC 60947-7-1 rated data	RT/SG2.5	RT/SG4
Voltage (V)	800	800
Impulse voltage (kV)	6	6
Pollution degree/Voltage category/Material group	3/III/1	3/III/1
Current (A)	24	32
Cross-section (mm <sup>2</sup> )	2.5	4

Description	Type	Ordering No.	Qty.	Type	Ordering No.	Qty.														
Terminal block, for mounting on TH 35-7.5, 15	RT/SG2.5	60104210	100	RT/SG4	60104220	85														
End plate	EP-RT/SG2.5-10	6020206003	50	EP-RT/SG2.5-10	6020206003	50														
Width (mm)	2.2			2.2																
Partition	GP	6020305005	20	GP	6020305005	20														
Width (mm)	3			3																
End bracket, for TH 35-7.5, 15 width (mm)	EB/4	6020101006	50	EB/4	6020101006	50														
	8			8																
	EB/3	6020101003	50	EB/3	6020101003	50														
	10			10																
	EB/1	6020101001	50	EB/1	6020101001	50														
	9.5			9.5																
Bridge screwless	BS 10-2.5 10-pos. BS 3-2.5 3-pos. BS 2-2.5 2-pos.	6020505009 6020505002 6020505001	10 100 100	BS 10-4 10-pos. BS 3-4 3-pos. BS 2-4 2-pos.	6020505109 6020505102 6020505101	10 100 100														
Maximum current (A)	24			32																
Bridge-comb	-	-	-	BC 10-2.5 10-pos. BC 3-2.5 3-pos. BC 2-2.5 2-pos.	6020504009 6020504002 6020504001	10 50 50														
max. current (A)				24																
Screw Driver	0.5x3.0	-	-	0.5x3.0	-	-														
Marking Tags	NS5	For details see Accessories		NS6	For details see Accessories															
Marking Holder	Marking Holder	6032100001	10	Marking Holder	6032100001	10														
Strip Lable	TBSL 22x20	For details see Accessories		TBSL 22x20	For details see Accessories															
Color (Color Code is the last 2 digits of the Ordering No.)		01	02	03	04	05	06	07	09	10		01	02	03	04	05	06	07	09	10
<b>Dimensions (mm)</b>	<b>W / L / H</b>				<b>W / L / H</b>															
Width/Length/Height, TH 35-7.5	5.2/45.2/47.8				6/45.2/47.8															
Width/Length/Height, TH 35-15	5.2/45.2/55.3				6/45.2/55.3															
<b>Connection capacity</b>																				
Rigid Solid (mm <sup>2</sup> )	0.5-4				0.5-6															
Rigid stranded (mm <sup>2</sup> )	0.5-4				0.5-6															
Flexible (mm <sup>2</sup> )	0.5-2.5				0.5-4															
American Wire Gauge (AWG)	20-12				20-10															
<b>IEC test gauge</b>	<b>A3</b>				<b>A4</b>															
Stripping length (mm)	10				10															
<b>Clamping screw/ Tightening torque (N.m)</b>	<b>M2.6/0.6</b>				<b>M2.6/0.6</b>															
Insulation material	PA				PA															

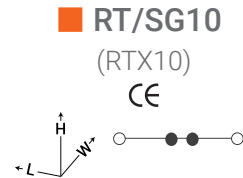
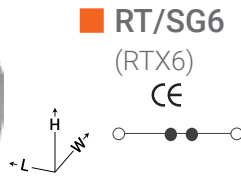
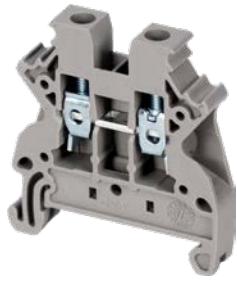

IEC 60947-7-1 rated data		RT/SG6			RT/SG10		
Voltage (V)		800			800		
Impulse voltage (kV)		8			8		
Pollution degree/ Voltage category/ Material group		3/III/I			3/III/I		
Current (A)		41			57		
Cross-section (mm <sup>2</sup> )		6			10		
Description	Type	Ordering No.	Qty.	Type	Ordering No.	Qty.	
Terminal block, for mounting on TH 35-7.5, 15	RT/SG6	60104230	65	RT/SG10	60104240	50	
End plate Width (mm)	EP-RT/SG2.5-10 2.2	6020206003	50	EP-RT/SG2.5-10 2.2	6020206003	50	
Partition Width (mm)	GP 3	6020305005	20	GP 3	6020305005	20	
End bracket, for TH 35-7.5, 15 width (mm)	EB/4 8 EB/3 10 EB/1 9.5	6020101006 6020101003 6020101001	50 50 50	EB/4 8 EB/3 10 EB/1 9.5	6020101006 6020101003 6020101001	50 50 50	
Bridge screwless	BS 10-6 10-pos. BS 3-6 3-pos. BS 2-6 2-pos.	6020505209 6020505203 6020505201	10 100 100	- BS 3-10 3-pos. BS 2-10 2-pos.	- 6020505302 6020505301	- 10 10	
max. current (A)	41			57			
Bridge-comb	JEB10-6 10-pos. JEB3-6 3-pos. JEB2-6 2-pos.	6020506009 6020506002 6020506001	10 50 50	-	-	-	
max. current (A)	41						
Screw Driver	0.6x3.5	-	-	1.0x4.0	-	-	
Marking Tags	1 2 3	NS8	For details see Accessories	NS10	For details see Accessories		
Marking Holder		Marking Holder	6032100001 10	Marking Holder	6032100001 10		
Strip Lable	1 2 3	TBSL 22x20	For details see Accessories	TBSL 22x20	For details see Accessories		
Color (Color Code is the last 2 digits of the Ordering No.)		01 02 03 04 05 06 07 09 10			01 02 03 04 05 06 07 09 10		
Dimensions (mm)	W / L / H			W / L / H			
Width/Length/Height, TH 35-7.5	8/45.2/47.8			10/45.2/47.8			
Width/Length/Height, TH 35-15	8/45.2/55.3			10/45.2/55.3			
Connection capacity							
Rigid Solid (mm <sup>2</sup> )	0.5-10			0.5-16			
Rigid stranded (mm <sup>2</sup> )	0.5-10			0.5-16			
Flexible (mm <sup>2</sup> )	0.5-6			0.5-10			
American Wire Gauge (AWG)	20-8			20-6			
IEC test gauge	A5			B6			
Stripping length (mm)	10			10			
Clamping screw/ Tightening torque (N.m)	M3.5/1.2			M4/1.5			
Insulation material	PA			PA			



■ RT/SG2.5-2L

CE

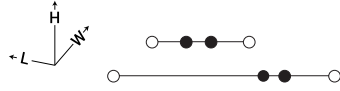

■ RT/SG4-2L

CE

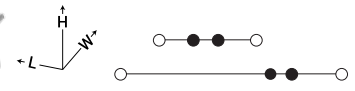

IEC 60947-7-1 rated data	RT/SG2.5-2L	RT/SG4-2L
voltage (V)	400	500
Impulse voltage (kV)	6	6
Pollution degree/Voltage category/Material group	3/III/1	3/III/1
Current (A)	24	32
Cross-section (mm <sup>2</sup> )	2.5	4

Description	Type	Ordering No.	Qty.	Type	Ordering No.	Qty.
Terminal block, for mounting on TH 35-7.5, 15	RT/SG2.5-2L	60107440	30	RT/SG4-2L	60107450	30
End plate Width (mm)	EP-RT/SG2.5-4-2L 1.2	6020203006	20	EP-RT/SG2.5-4-2L 1.2	6020203006	20
Partition Width (mm)	GP 3	6020305005	20	GP 3	6020305005	20
End bracket, for TH 35-7.5, 15 width (mm)	EB/4 8 EB/3 10 EB/2 10 EB/1 9.5	6020101006 6020101003 6020101002 6020101001	50 50 50 50	EB/4 8 EB/3 10 EB/2 10 EB/1 9.5	6020101006 6020101003 6020101002 6020101001	50 50 50 50
Bridge screwless	BS 10-2.5 10-pos. BS 3-2.5 3-pos. BS 2-2.5 2-pos.	6020505009 6020505002 6020505001	10 100 100	BS 10-4 10-pos. BS 3-4 3-pos. BS 2-4 2-pos.	6020505109 6020505102 6020505101	10 100 100
Maximum current (A)	24			32		
Bridge-comb	-	-	-	BC 10-2.5 10-pos. BC 3-2.5 3-pos. BC 2-2.5 2-pos.	6020504009 6020504002 6020504001	10 50 50
Maximum current (A)				24		
Screw Driver	0.5x3.0	-	-	0.5x3.0	-	-
Marking Tags	NS5	For details see Accessories		NS6	For details see Accessories	
Marking Holder	Marking Holder	6032100001	10	Marking Holder	6032100001	10
Strip Lable	TBSL 22x20	For details see Accessories		TBSL 22x20	For details see Accessories	
Color (Color Code is the last 2 digits of the Ordering No.)	17  18			05  06		

Dimensions (mm)	W / L / H	W / L / H
Width/Length/Height, TH 35-7.5	5.2/72/63	6/72/63
Width/Length/Height, TH 35-15	5.2/72/70.5	6/72/70.5
Connection capacity		
Rigid Solid (mm <sup>2</sup> )	0.5-4	0.5-6
Rigid stranded (mm <sup>2</sup> )	0.5-4	0.5-6
Flexible (mm <sup>2</sup> )	0.5-2.5	0.5-4
American Wire Gauge (AWG)	20-12	20-10
IEC test gauge	A3	A4
Stripping length (mm)	10	10
Clamping screw/ Tightening torque (N.m)	M2.6/0.6	M2.6/0.6
Insulation material	PA	PA

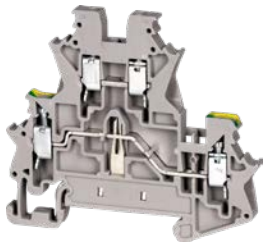

■ RT/SG2.5-2LE

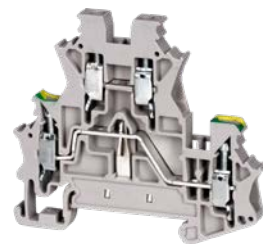
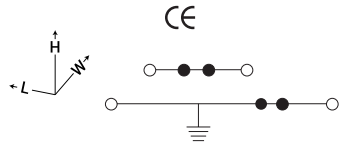

■ RT/SG4-2LE

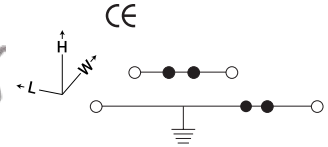

IEC 60947-7-1 IEC 60947-7-2 rated data	RT/SG2.5-2LE	RT/SG4-2LE
voltage (V)	400	500
Impulse voltage (kV)	6	6
Pollution degree/Voltage category /Material group	3/III/I	3/III/I
Current (A)	24	32
Cross-section (mm <sup>2</sup> )	2.5	4

Description	Type	Ordering No.	Qty.	Type	Ordering No.	Qty.
Terminal block, for mounting on TH 35-7.5, 15	RT/SG2.5-2LE	6010744015	30	RT/SG4-2LE	6010603015	30
End plate Width (mm)	EP-RT/SG2.5-4-2L 1.2	6020203006	20	EP-RT/SG2.5-4-2L 1.2	6020203006	20
Partition Width (mm)	GP 3	6020305005	20	GP 3	6020305005	20
End bracket, for TH 35-7.5, 15 width (mm)	EB/4 8 EB/3 10 EB/2 10 EB/1 9.5	6020101006 6020101003 6020101002 6020203006	50 50 50 50	EB/4 8 EB/3 10 EB/2 10 EB/1 9.5	6020101006 6020101003 6020101002 6020203006	50 50 50 50
Bridge screwless	BS 10-2.5 10-pos. BS 3-2.5 3-pos. BS 2-2.5 2-pos.	6020505009 6020505002 6020505001	10 100 100	BS 10-4 10-pos. BS 3-4 3-pos. BS 2-4 2-pos.	6020505109 6020505102 6020505101	10 100 100
Maximum current (A)	24			32		
Bridge-comb	-	-	-	BC 10-2.5 10-pos. BC 3-2.5 3-pos. BC 2-2.5 2-pos.	6020504009 6020504002 6020504001	10 50 50
max. current (A)				24		
Screw Driver	0.5x3.0	-	-	0.5x3.0	-	-
Marking Tags	NS5	For details see Accessories		NS6	For details see Accessories	
Marking Holder	Marking Holder	6032100001	10	Marking Holder	6032100001	10
Strip Lable	TBSL 22x20	For details see Accessories		TBSL 22x20	For details see Accessories	

Dimensions (mm)	W / L / H	W / L / H
Width/Length/Height, TH 35-7.5	5.2/72/63	6/72/63
Width/Length/Height, TH 35-15	5.2/72/70.5	6/72/70.5
Connection capacity		
Rigid Solid (mm <sup>2</sup> )	0.5-4	0.5-6
Rigid stranded (mm <sup>2</sup> )	0.5-4	0.5-6
Flexible (mm <sup>2</sup> )	0.5-2.5	0.5-4
American Wire Gauge (AWG)	20-12	20-10
IEC test gauge	A3	A4
Stripping length (mm)	10	10
Clamping screw/ Tightening torque (N.m)	M2.6/0.6	M2.6/0.6
Insulation material	PA	PA



**RAAD**  <sup>®</sup> Electrical Connection for  
Technological Components  
*Confidence in Connection*

# Protective General Terminal Blocks



RT/SG-E terminal the same as RT/SG series with connection capacity of screw clamp, reliable capability are be used and they have following advantages:

- 
- Space-saving design, optimizing handling and easy assembling
- Strong connection on TH7.5,15 rails
- Compatibility of all size from 2.5-10 mm<sup>2</sup>
- Can be used strip labels without the need for a marking holder
- Terminal insulation body polyamide
- Similar partition for several types



**RT/SG2.5-E**  
(RETX2.5)

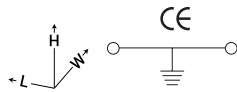

**RT/SG4-E**  
(RETX4)

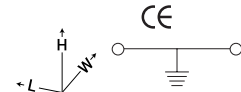

IEC 60947-7-2 rated data	RT/SG2.5-E	RT/SG4-E
Impulse voltage (kV)	6	6
Pollution degree/Voltage category/Material group	3/III/1	3/III/1
Cross-section (mm <sup>2</sup> )	2.5	4

Description	Type	Ordering No.	Qty.	Type	Ordering No.	Qty.
Terminal block, for mounting on TH 35-7.5, 15	RT/SG2.5-E	6010604001	70	RT/SG4-E	6010604002	60
End plate	EP-RT/SG2.5-10E	6020206004	50	EP-RT/SG2.5-10E	6020206004	50
Width (mm)	2.2			2.2		
Partition	GP	6020305005	20	GP	6020305005	20
Width (mm)	3			3		
End bracket, for TH 35-7.5, 15 width (mm)	EB/4	6020101006	50	EB/4	6020101006	50
	8			8		
	EB/3	6020101003	50	EB/3	6020101003	50
	10			10		
	EB/1	6020101001	50	EB/1	6020101001	50
	9.5			9.5		
Screw Driver	0.5x3.0	-	-	0.5x3.0	-	-
Marking Tags	NS5	For details see Accessories		NS6	For details see Accessories	
Marking Holder	Marking Holder	6032100001	10	Marking Holder	6032100001	10
Strip Lable	TBSL 22x20	For details see Accessories		TBSL 22x20	For details see Accessories	
Color						

Dimensions (mm)	W / L / H	W / L / H
Width/Length/Height, TH 35-7.5	5.2/45.2/47.8	6/45.2/47.8
Width/Length/Height, TH 35-15	5.2/45.2/55.3	6/45.2/55.3
Connection capacity		
Rigid Solid (mm <sup>2</sup> )	0.5-4	0.5-6
Rigid stranded (mm <sup>2</sup> )	0.5-4	0.5-6
Flexible (mm <sup>2</sup> )	0.5-2.5	0.5-4
American Wire Gauge (AWG)	20-12	20-10
IEC test gauge		
Stripping length (mm)	10	10
Clamping screw/ Tightening torque (N.m)		
	M2.6/0.6	M2.6/0.6
Insulation material	PA	PA

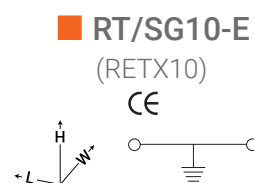
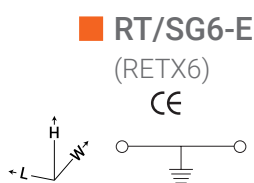

IEC 60947-7-2 rated data	RT/SG6-E	RT/SG10-E
Impulse voltage (kV)	8	8
Pollution degree/Voltage category/Material group	3/III/I	3/III/I
Current (A)	-	57
Cross-section (mm <sup>2</sup> )	6	10

Description	Type	Ordering No.	Qty.	Type	Ordering No.	Qty.
Terminal block, for mounting on TH 35-7.5, 15	RT/SG6-E	6010604003	45	RT/SG10-E	6010604004	35
End plate Width (mm)	EP-RT/SG2.5-10E 2.2	6020206004	50	EP-RT/SG2.5-10E 2.2	6020206004	50
Partition Width (mm)	GP 3	6020305005	20	GP 3	6020305005	20
End bracket, for TH 35-7.5, 15 width (mm)	EB/4 8 EB/3 10 EB/1 9.5	6020101006 6020101003 6020101001	50 50 50	EB/4 8 EB/3 10 EB/1 9.5	6020101006 6020101003 6020101001	50 50 50
Screw Driver	0.5x3.5	-	-	1.0x4.0	-	-
Marking Tags	NS8	For details see Accessories		NS10	For details see Accessories	
Marking Holder	Marking Holder	6032100001	10	Marking Holder	6032100001	10
Strip Lable	TBSL 22x20	For details see Accessories		TBSL 22x20	For details see Accessories	
Color						

Dimensions (mm)	W / L / H	W / L / H
Width/Length/Height, TH 35-7.5	8/45.2/47.8	10/45.2/47.8
Width/Length/Height, TH 35-15	8/45.2/55.3	10/45.2/55.3
Connection capacity		
Rigid Solid (mm <sup>2</sup> )	0.5-10	0.5-16
Rigid stranded (mm <sup>2</sup> )	0.5-10	0.5-16
Flexible (mm <sup>2</sup> )	0.5-6	0.5-10
American Wire Gauge (AWG)	20-8	20-6
IEC test gauge	A5	B6
Stripping length (mm)	10	10
Clamping screw/ Tightening torque (N.m)	M3.5/1.2	M4/1.5
Insulation material	PA	PA

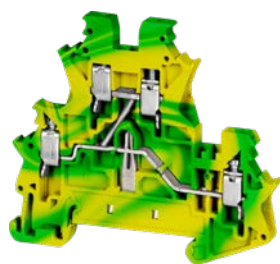

■ RT/SG2.5-2L2E

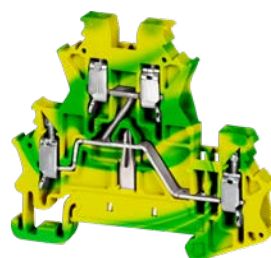
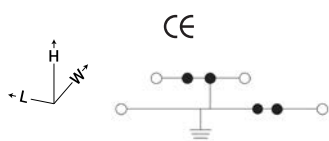

■ RT/SG4-2L2E

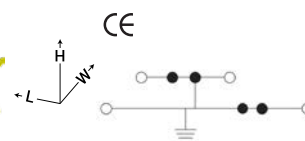

IEC 60947-7-2 rated data	RT/SG2.5-2L2E	RT/SG4-2L2E
Impulse voltage (kV)	6	6
Pollution degree/Voltage category/Material group	3/III/1	3/III/1
Cross-section (mm <sup>2</sup> )	2.5	4

Description	Type	Ordering No.	Qty.	Type	Ordering No.	Qty.
Terminal block, for mounting on TH 35-7.5, 15	RT/SG2.5-2L2E	6010744016	30	RT/SG4-2L2E	6010603016	30
End plate Width (mm)	EP-RT/SG2.5-4-2L2E 1.2	6020206005	20	EP-RT/SG2.5-4-2L2E 1.2	6020206005	20
Partition Width (mm)	GP 3	6020305005	20	GP 3	6020305005	20
End bracket, for TH 35-7.5, 15 width (mm)	EB/4 8	6020101006	50	EB/4 8	6020101006	50
	EB/3 10	6020101003	50	EB/3 10	6020101003	50
	EB/2 10	6020101002	50	EB/2 10	6020101002	50
	EB/1 9.5	6020101001	50	EB/1 9.5	6020101001	50
Screw Driver	0.5x3.0	-	-	0.5x3.0	-	-
Marking Tags	NS5	For details see Accessories		NS6	For details see Accessories	
Marking Holder	Marking Holder	6032100001	10	Marking Holder	6032100001	10
Strip Lable	TBSL 22x20	For details see Accessories		TBSL 22x20	For details see Accessories	

Dimensions (mm)	W / L / H	W / L / H
Width/Length/Height, TH 35-7.5	5.2/72/63	6/72/63
Width/Length/Height, TH 35-15	5.2/72/70.5	6/72/70.5
Connection capacity		
Rigid Solid (mm <sup>2</sup> )	0.5-4	0.5-6
Rigid stranded (mm <sup>2</sup> )	0.5-4	0.5-6
Flexible (mm <sup>2</sup> )	0.5-2.5	0.5-4
American Wire Gauge (AWG)	20-12	20-10
IEC test gauge		
Stripping length (mm)	10	10
Clamping screw/ Tightening torque (N.m)		
	M2.6/0.6	M2.6/0.6
Insulation material		
	PA	PA





**RAAD**  <sup>®</sup> Electrical Connection for  
Technological Components  
*Confidence in Connection*

# Push-In Connection Terminal Blocks

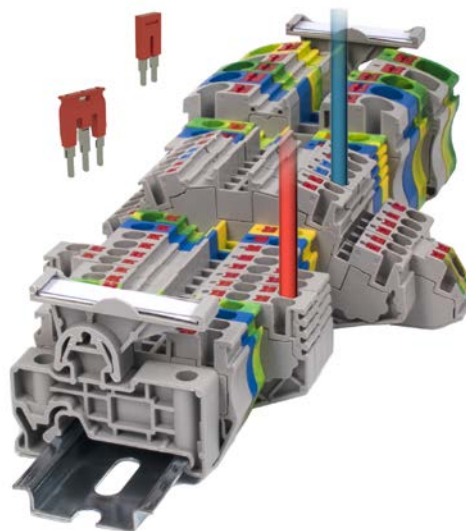

## Push-In Connection

RT/PG series is characterized by the simple handling and tool-free connection method. RT/PG series clamping method allows you to push in the solid conductors (no preparation needed) and flexible cables (using ferrules) and ensures a confident connection by opening the contact spring automatically after the cables are pushed into the clamps. This kind of connection is vibration-proof.

Tool-free wiring technology in RAAD push-in terminal blocks characterizes this type of terminal by the following advantages:

- Direct inserting of solid conductors or prepared cables with ferrules (no tools needed).
- Easy release of conductors by the plastic actuation lever using a tool without touching live parts.
- Space-saving design, optimized handling, and easy assembling.
- Easy insertion of conductors by a little pushing force.

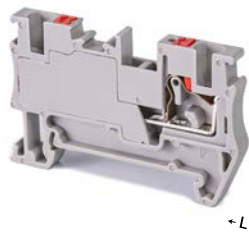

**RT/PG2.5**  
(RPIT2.5)

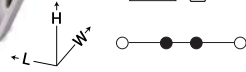

**RT/PG4**  
(RPIT4)

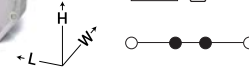

Technical data	RT/PG2.5		RT/PG4	
	Voltage(V)	Current(A)	Voltage(V)	Current(A)
IEC 60947-7-1	800	24	800	32
IEC/EN 60079-7	500	22	500	28
<b>IEC 60947-7-1 rated data</b>				
Impulse voltage (kV)	8		8	
Pollution degree/Voltage category/Material group	3/III/1		3/III/1	
Cross-section (mm <sup>2</sup> )	2.5		4	

Description	Type	Ordering No.	Qty.	Type	Ordering No.	Qty.
Terminal block, for mounting on TH 35-7.5, 15	RT/PG2.5	60110010	100	RT/PG4	60110020	100
Partition	P-RPIT2.5-10	6020307001	50	P-RPIT2.5-10	6020307001	50
Width (mm)	2			2		
End bracket, for TH 35-7.5, 15 width (mm)	EB/4	6020101006	50	EB/4	6020101006	50
	8	6020101003	50	8	6020101003	50
	EB/3	6020101003	50	EB/3	6020101003	50
	10	6020101001	50	10	6020101001	50
	EB/1	6020101001	50	EB/1	6020101001	50
	9.5			9.5		
Bridge screwless	BS 10-2.5 10-pos.	6020505009	10	BS 10-4 10-pos.	6020505109	10
	BS 3-2.5 3-pos.	6020505002	100	BS 3-4 3-pos.	6020505102	100
	BS 2-2.5 2-pos.	6020505001	100	BS 2-4 2-pos.	6020505101	100
Maximum current (A)	20			26		
Marking Tags	NS5	For details see Accessories		NS6	For details see Accessories	
Marking Holder	Marking Holder	6032100001	10	Marking Holder	6032100001	10
Strip Lable	TBSL 22x20	For details see Accessories		TBSL 22x20	For details see Accessories	
Color (Color Code is the last 2 digits of the Ordering No.)						
<b>Dimensions (mm)</b>	<b>W / L / H</b>			<b>W / L / H</b>		
Width/Length/Height, TH 35-7.5	5.2/54.2/36			6/54.2/36		
Width/Length/Height, TH 35-15	5.2/54.2/43.5			6/54.2/43.5		
<b>Connection capacity</b>						
Rigid Solid (mm <sup>2</sup> )	0.5-4			0.5-6		
Rigid stranded (mm <sup>2</sup> )*	0.5-2.5			0.5-4		
Flexible (mm <sup>2</sup> )*	0.5-2.5			0.5-4		
American Wire Gauge (AWG)	20-12			20-10		
<b>IEC test gauge</b>	<b>A3</b>			<b>A4</b>		
Stripping length (mm)	12			12		
<b>Insulation material</b>	<b>PA</b>			<b>PA</b>		

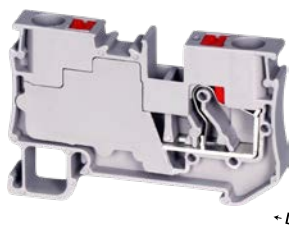

### RT/PG6

(RPIT6)

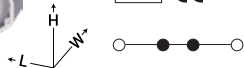

### RT/PG10

(RPIT10)

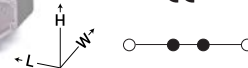

IEC 60947-7-1 rated data	RT/PG6	RT/PG10
Voltage (V)	1000	1000
Impulse voltage (kV)	8	8
Pollution degree/Voltage category/Material group	3/III/I	3/III/I
Current (A)	41	57
Cross-section (mm <sup>2</sup> )	6	10

Description	Type	Ordering No.	Qty.	Type	Ordering No.	Qty.
Terminal block, for mounting on TH 35-7.5, 15	RT/PG6	60110030	50	RT/PG10	60110040	30
Partition	P-RPIT2.5-10	6020307001	50	P-RPIT2.5-10	6020307001	50
Width (mm)	2			2		
End bracket, for TH 35-7.5, 15 width (mm)	EB/4	6020101006	50	EB/4	6020101006	50
	8	6020101003	50	8	6020101003	50
	EB/3	6020101003	50	EB/3	6020101003	50
	10	6020101001	50	10	6020101001	50
	EB/1	6020101001	50	EB/1	6020101001	50
	9.5			9.5		
Bridge screwless	BS10-6 10-pos.	6020505209	50	BS3-10 3pos.	6020505302	10
	BS 3-6 3-pos.	6020505203	50	BS2-10 2pos.	6020505301	10
	BS 2-6 2-pos.	6020505201	50			
Marking Tags	NS8	For details see Accessories		NS10	For details see Accessories	
Marking Holder	Marking Holder	6032100001	10	Marking Holder	6032100001	10
Strip Lable	TBSL 22x20	For details see Accessories		TBSL 22x20	For details see Accessories	
Color (Color Code is the last 2 digits of the Ordering No.)						
<b>Dimensions (mm)</b>	<b>W / L / H</b>			<b>W / L / H</b>		
Width/Length/Height, TH 35-7.5	8/62/42			10/68.5/51		
Width/Length/Height, TH 35-15	8/62/49.5			10/68.5/58.5		
<b>Connection capacity</b>						
Rigid Solid (mm <sup>2</sup> )	0.5-10			0.5-16		
Rigid stranded (mm <sup>2</sup> )*	0.5-6			0.5-10		
Flexible (mm <sup>2</sup> )*	0.5-6			0.5-10		
American Wire Gauge (AWG)	20-8			20-6		
<b>IEC test gauge</b>	<b>A5</b>			<b>A6</b>		
Stripping length (mm)	12			18		
<b>Insulation material</b>	<b>PA</b>			<b>PA</b>		

\* Prepare this kind of cable with ferrule.



## RT/PG16

(RPIT16)

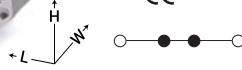

IEC 60947-7-1 rated data	RT/PG16
Voltage (V)	1000
Impulse voltage (kV)	8
Pollution degree/Voltage category/Material group	3/III/I
Current (A)	76
Cross-section (mm <sup>2</sup> )	16

Description	Type	Ordering No.	Qty.
Terminal block, for mounting on TH 35-7.5, 15	RT/PG16	60110070	25
End bracket, for TH 35-7.5, 15 width (mm)	EB/4 8 EB/3 10 EB/1 9.5	6020101006 6020101003 6020101001	50 50 50
Bridge screwless	BS2-16 2pos.	6020505401	10
Marking Tags	NS10 RAAD recommended	For details see Accessories	
Marking Holder	Marking Holder	6032100001	10
Strip Lable	TBSL 22x20	For details see Accessories	
Color (Color Code is the last 2 digits of the Ordering No.)		01   02   03   04   05   06   07   09   10	
<b>Dimensions (mm)</b>	<b>W / L / H</b>		
Width/Length/Height, TH 35-7.5	12/71.5/51		
Width/Length/Height, TH 35-15	12/71.5/58.5		
<b>Connection capacity</b>			
Rigid Solid (mm <sup>2</sup> )	0.5-16		
Rigid stranded (mm <sup>2</sup> )*	0.5-16		
Flexible (mm <sup>2</sup> )*	0.5-16		
American Wire Gauge (AWG)	20-6		
<b>IEC test gauge</b>	<b>A7</b>		
Stripping length (mm)	18		
<b>Insulation material</b>	<b>PA</b>		

\* Prepare this kind of cable with ferrule.





**RAAD**  <sup>®</sup> Electrical Connection for  
Technological Components  
*Confidence in Connection*

# Earth Push-In Protective Terminal Blocks



Some of the most practical advantages of using RT/PG-E series are as follows:

- Meets all IEC 60947-7-2 requirements
- Significant time and cost savings
- Stainless steel spring continuously provides sufficient contact force between conductor and current carrying part
- Compact construction and high-performance contact technology
- Insulation housing made of high-grade fire resistant PA
- Safe and tool-less connecting
- Mountable on TH35 rail
- Easy release of a conductor by using tools

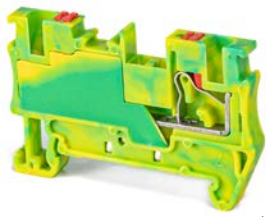

### RT/PG2.5-E

(RPET2.5)

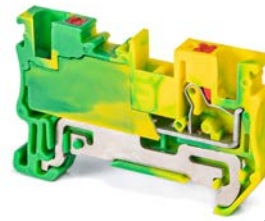
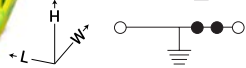





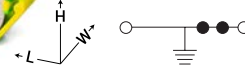

### RT/PG4-E

(RPET4)

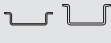

IEC 60947-7-2 rated data	RT/PG2.5-E	RT/PG4-E
Impulse voltage (kV)	8	8
Pollution degree/Voltage category/Material group	3/III/I	3/III/I
Current (A)	-	-
Cross-section (mm <sup>2</sup> )	2.5	4

Description	Type	Ordering No.	Qty.	Type	Ordering No.	Qty.
Terminal block, for mounting on TH 35-7.5, 15 	RT/PG2.5-E	6011201001	50	RT/PG4-E	6011201002	50
Partition 	P-RPIT2.5-10	6020307001	50	P-RPIT2.5-10	6020307001	50
Width (mm)	2			2		
End bracket, for TH 35-7.5, 15 width (mm) 	EB/4	6020101006	50	EB/4	6020101006	50
	8			8		
	EB/3	6020101003	50	EB/3	6020101003	50
	10			10		
	EB/1	6020101001	50	EB/1	6020101001	50
	9.5			9.5		
Marking Tags 	NS5	For details see Accessories		NS6	For details see Accessories	
Marking Holder 	Marking Holder	6032100001	10	Marking Holder	6032100001	10
Strip Lable 	TBSL 22x20	For details see Accessories		TBSL 22x20	For details see Accessories	
Dimensions (mm)	W / L / H			W / L / H		
Width/Length/Height, TH 35-7.5	5.2/54.2/36			6/54.2/36		
Width/Length/Height, TH 35-15	5.2/54.2/43.5			6/54.2/43.5		
Connection capacity						
Rigid Solid (mm <sup>2</sup> )	0.5-4			0.5-6		
Rigid stranded (mm <sup>2</sup> )*	0.5-2.5			0.5-4		
Flexible (mm <sup>2</sup> )*	0.5-2.5			1.5-4		
American Wire Gauge (AWG)	20-12			20-10		
IEC test gauge	A3			A4		
Stripping length (mm)	12			12		
Insulation material	PA			PA		

\* Prepare this kind of cable with ferrule.

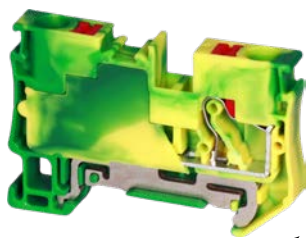

### RT/PG6-E

(RPET6)

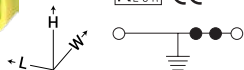

### RT/PG10-E

(RPET10)

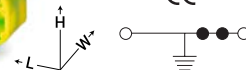

IEC 60947-7-2 rated data	RT/PG6-E	RT/PG10-E
Impulse voltage (kV)	8	8
Pollution degree/Voltage category/Material group	3/III/I	3/III/I
Current (A)	-	57
Cross-section (mm <sup>2</sup> )	6	10

Description	Type	Ordering No.	Qty.	Type	Ordering No.	Qty.
Terminal block, for mounting on TH 35-7.5, 15	RT/PG6-E	6011201003	25	RT/PG10-E	6011201003	30
Partition	P-RPIT2.5-10	6020307001	50	P-RPIT2.5-10	6020307001	50
Width (mm)	2			2		
End bracket, for TH 35-7.5, 15 width (mm)	EB/4	6020101006	50	EB/4	6020101006	50
	8	6020101003	50	8	6020101003	50
	EB/3	6020101003	50	EB/3	6020101003	50
	10	6020101001	50	10	6020101001	50
	EB/1	6020101001	50	EB/1	6020101001	50
	9.5			9.5		
Marking Tags	NS8	For details see Accessories		NS10	For details see Accessories	
Marking Holder	Marking Holder	6032100001	10	Marking Holder	6032100001	10

Dimensions (mm)	W / L / H	W / L / H
Width/Length/Height, TH 35-7.5	8/62/42	10/68.5/51
Width/Length/Height, TH 35-15	8/62/49.5	10/68.5/58.5
Connection capacity		
Rigid Solid (mm <sup>2</sup> )	0.5-10	0.5-16
Rigid stranded (mm <sup>2</sup> )*	0.5-6	0.5-10
Flexible (mm <sup>2</sup> )*	1.5-6	0.5-10
American Wire Gauge (AWG)	20-8	20-6
IEC test gauge	A5	A6
Stripping length (mm)	12	18
Insulation material	PA	PA

\* Prepare this kind of cable with ferrule.



RT/PG16-E

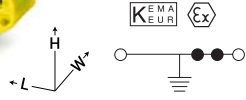

RT/PG4-2L2E

(DPET4)

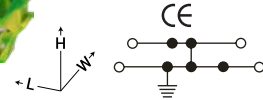

IEC 60947-7-2 rated data	RT/PG16-E	RT/PG4-2L2E
Impulse voltage (kV)	8	8
Pollution degree/ Voltage category/Material group	3/III/1	3/III/1
Current (A)	76	-
Cross-section (mm <sup>2</sup> )	16	4

Description	Type	Ordering No.	Qty.	Type	Ordering No.	Qty.
Terminal block, for mounting on TH 35-7.5, 15	RT/PG16-E	6011201005	50	RT/PG4-2L2E	6011203003	50
End bracket, for TH 35-7.5, 15 width (mm)	EB/4	6020101006	50	EB/4	6020101006	50
	8			8		
	EB/3	6020101003	50	EB/3	6020101003	50
	10			10		
	EB/1	6020101001	50	EB/1	6020101001	50
	9.5			9.5		
Partition Width (mm)	-	-	-	GP 3	6020305005	20
Marking Tags	NS10 RAAD recommended	For details see Accessories		NS6	For details see Accessories	
Marking Holder	Marking Holder	6032100001	10	Marking Holder	6032100001	10
Strip Lable	TBSL 22x20	For details see Accessories		TBSL 22x20	For details see Accessories	
Color						
<b>Dimensions (mm)</b>	<b>W / L / H</b>			<b>W / L / H</b>		
Width/Length/Height, TH 35-7.5	12/71.5/51			6/88/50.5		
Width/Length/Height, TH 35-15	12/71.5/58.5			6/88/58		
<b>Connection capacity</b>						
Rigid Solid (mm <sup>2</sup> )	0.5-16			0.5-6		
Rigid stranded (mm <sup>2</sup> )*	0.5-16			0.5-4		
Flexible (mm <sup>2</sup> )*	0.5-16			0.5-4		
American Wire Gauge (AWG)	20-6			20-10		
<b>IEC test gauge</b>	<b>A7</b>			<b>A4</b>		
Stripping length (mm)	18			12		
<b>Insulation material</b>	<b>PA</b>			<b>PA</b>		

\* Prepare this kind of cable with ferrule.



BIHLER

RM



**RAAD**  <sup>®</sup> Electrical Connection for  
Technological Components  
*Confidence in Connection*

# Multi-Level Push-In Terminal Blocks

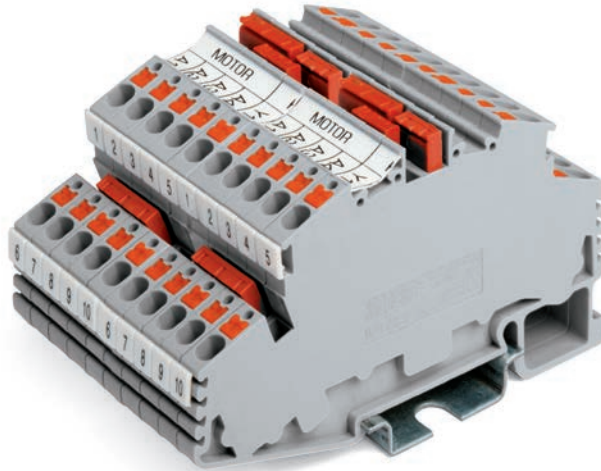

RAAD push-in multi-Level terminal blocks enjoy the space-saving benefit, and the following advantages are met:

- In RT/PG-2L, it is significant that due to its double wiring density, it can be used as two terminals in one terminal, which will reduce the space occupied by the terminals in the electrical panel.
- RT/PG-3L0E5 terminal blocks were specially developed for space-saving wiring in three wired elements such as motors and sensors, e.g. phase-neutral-earth connection or positive-negative-earth/shield connection.
- As for foot connection, RAAD push-in multi-level terminals can be mounted on the TH35 mounting rail.
- High resistance to fire due to the use of PA materials.
- All terminal blocks are in accordance with the IEC 60947-7-1 standard and in the earth level of RT/PG4-2LE and RT/PG2.5-3L0E5 terminal comply with IEC60947-7-2 standard.

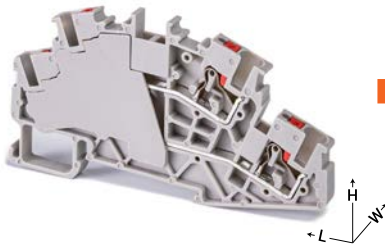

### RT/PG2.5-2L

(DPIT2.5)

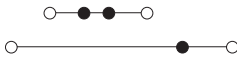

### RT/PG4-2L

(DPIT4)

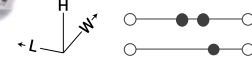

IEC 60947-7-1 rated data	RT/PG2.5-2L	RT/PG4-2L
Voltage (V)	500	500
Impulse voltage (kV)	6	8
Pollution degree/Voltage category/Material group	3/III/1	3/III/1
Current (A)	24	32
Cross-section (mm <sup>2</sup> )	2.5	4

Description	Type	Ordering No.	Qty.	Type	Ordering No.	Qty.
Terminal block, for mounting on TH 35-7.5, 15	RT/PG2.5-2L	6011101001	50	RT/PG4-2L	6011102005	50
End bracket, for TH 35-7.5, 15 width (mm)	EB/4 8	6020101006	50	EB/4 8	6020101006	50
	EB/3 10	6020101003	50	EB/3 10	6020101003	50
	EB/1 9.5	6020101001	50	EB/1 9.5	6020101001	50
Bridge screwless	BS 10-2.5 10-pos.	6020505009	10	BS10-4 10-pos.	6020505109	10
	BS 3-2.5 3-pos.	6020505002	100	BS3-4 3-pos.	6020505102	100
	BS 2-2.5 2-pos.	6020505001	100	BS2-4 2-pos.	6020505101	100
Partition	GP 3	6020305005	20	GP 3	6020305005	20
Width (mm)						
Marking Tags	NS5	For details see Accessories		NS6	For details see Accessories	
Marking Holder	Marking Holder	6032100001	10	Marking Holder	6032100001	10
Strip Lable	TBSL 22x20	For details see Accessories		TBSL 22x20	For details see Accessories	
Color						
<b>Dimensions (mm)</b>	<b>W / L / H</b>			<b>W / L / H</b>		
Width/Length/Height, TH 35-7.5	5.2/88/50.5			6/88/50.5		
Width/Length/Height, TH 35-15	5.2/88/58			6/88/58		
<b>Connection capacity</b>						
Rigid Solid (mm <sup>2</sup> )	0.5-4			0.5-6		
Rigid stranded (mm <sup>2</sup> )*	0.5-2.5			0.5-4		
Flexible (mm <sup>2</sup> )*	0.5-2.5			0.5-4		
American Wire Gauge (AWG)	20-12			20-10		
<b>IEC test gauge</b>	<b>A3</b>			<b>A4</b>		
Stripping length (mm)	12			12		
<b>Insulation material</b>	<b>PA</b>			<b>PA</b>		

\* Prepare this kind of cable with ferrule.

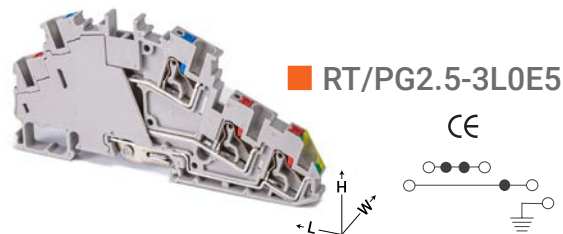
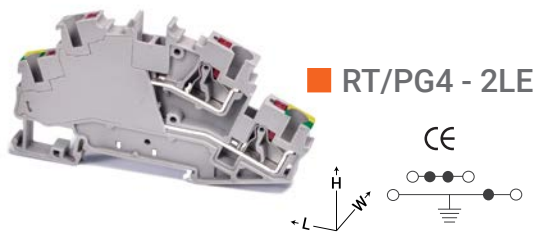

IEC 60947-7-1 IEC 60947-7-2 rated data	RT/PG4-2LE	RT/PG2.5-3L0E5
Voltage (V)	500	500
Impulse voltage (kV)	8	6
Pollution degree/Voltage category/Material group	3/III/I	3/III/I
Current (A)	32	24
Cross-section (mm <sup>2</sup> )	4	2.5

Description	Type	Ordering No.	Qty.	Type	Ordering No.	Qty.
Terminal block, for mounting on TH 35-7.5, 15	RT/PG4-2LE	6011203002	50	RT/PG2.5-3L0E5	6011202001	30
End bracket, for TH 35-7.5, 15 width (mm)	EB/4 8	6020101006	50	EB/4 8	6020101006	50
	EB/3 10	6020101003	50	EB/3 10	6020101003	50
	EB/1 9.5	6020101001	50	EB/1 9.5	6020101001	50
Bridge screwless	BS10-4 10-pos. BS3-4 3-pos. BS2-4 2-pos.	6020505109 6020505102 6020505101	10 100 100	BS10-2.5 10-pos. BS3-2.5 3-pos. BS2-2.5 2-pos.	BS10-2.5 10-pos.	10 100 100
Partition	GP 3	6020305005	20	GP 3	BS3-2.5 3-pos.	20
Width (mm)						
Marking Tags	NS6	For details see Accessories		NS5	BS2-2.5 2-pos.	
Marking Holder	Marking Holder	6032100001	10	Marking Holder	6032100001	10
Strip Lable	TBSL 22x20	For details see Accessories		TBSL 22x20	For details see Accessories	
Color						
<b>Dimensions (mm)</b>	<b>W / L / H</b>			<b>W / L / H</b>		
Width/Length/Height, TH 35-7.5	6/88/50.5			5.2/102/50.5		
Width/Length/Height, TH 35-15	6/88/58			5.2/102/58		
<b>Connection capacity</b>						
Rigid Solid (mm <sup>2</sup> )	0.5-6			0.5-4		
Rigid stranded (mm <sup>2</sup> )*	0.5-4			0.5-2.5		
Flexible (mm <sup>2</sup> )*	0.5-4			0.5-2.5		
American Wire Gauge (AWG)	20-10			20-12		
<b>IEC test gauge</b>	<b>A4</b>			<b>A3</b>		
Stripping length (mm)	12			12		
<b>Insulation material</b>	<b>PA</b>			<b>PA</b>		

\* Prepare this kind of cable with ferrule.



## RT/PG2.5-3L

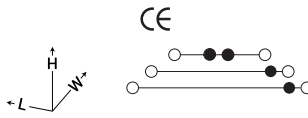

IEC 60947-7-1 rated data	RT/PG2.5-3L
Voltage (V)	500
Impulse voltage (kV)	6
Pollution degree/Voltage category/Material group	3/III/I
Current (A)	24
Cross-section (mm <sup>2</sup> )	2.5

Description	Type	Ordering No.	Qty.
Terminal block, for mounting on TH 35-7.5, 15	RT/PG2.5-3L	60111030	28
End bracket, for TH 35-7.5, 15 width (mm)	EB/4 8 EB/3 10 EB/1 9.5	6020101006 6020101003 6020101001	50 50 50
Bridge screwless	BS10-2.5 10-pos. BS3-2.5 3-pos. BS2-2.5 2-pos.	6020505009 6020505002 6020505001	10 100 100
Marking Tags	NS5	For details see Accessories	
Marking Holder	Marking Holder	6032100001	10
Strip Label	TBSL 22x20	For details see Accessories	
Color (Color Code is the last 2 digits of the Ordering No.)	 01   02		
<b>Dimensions (mm)</b>	<b>W / L / H</b>		
Width/Length/Height, TH 35-7.5	5.2/116.9/64.8		
Width/Length/Height, TH 35-15	5.2/116.9/72.5		
<b>Connection capacity</b>			
Rigid Solid (mm <sup>2</sup> )	0.5-4		
Rigid stranded (mm <sup>2</sup> )*	0.5-2.5		
Flexible (mm <sup>2</sup> )*	0.5-2.5		
American Wire Gauge (AWG)	20-12		
<b>IEC test gauge</b>	<b>A3</b>		
Stripping length (mm)	12		
<b>Insulation material</b>	<b>PA</b>		

\* Prepare this kind of cable with ferrule.

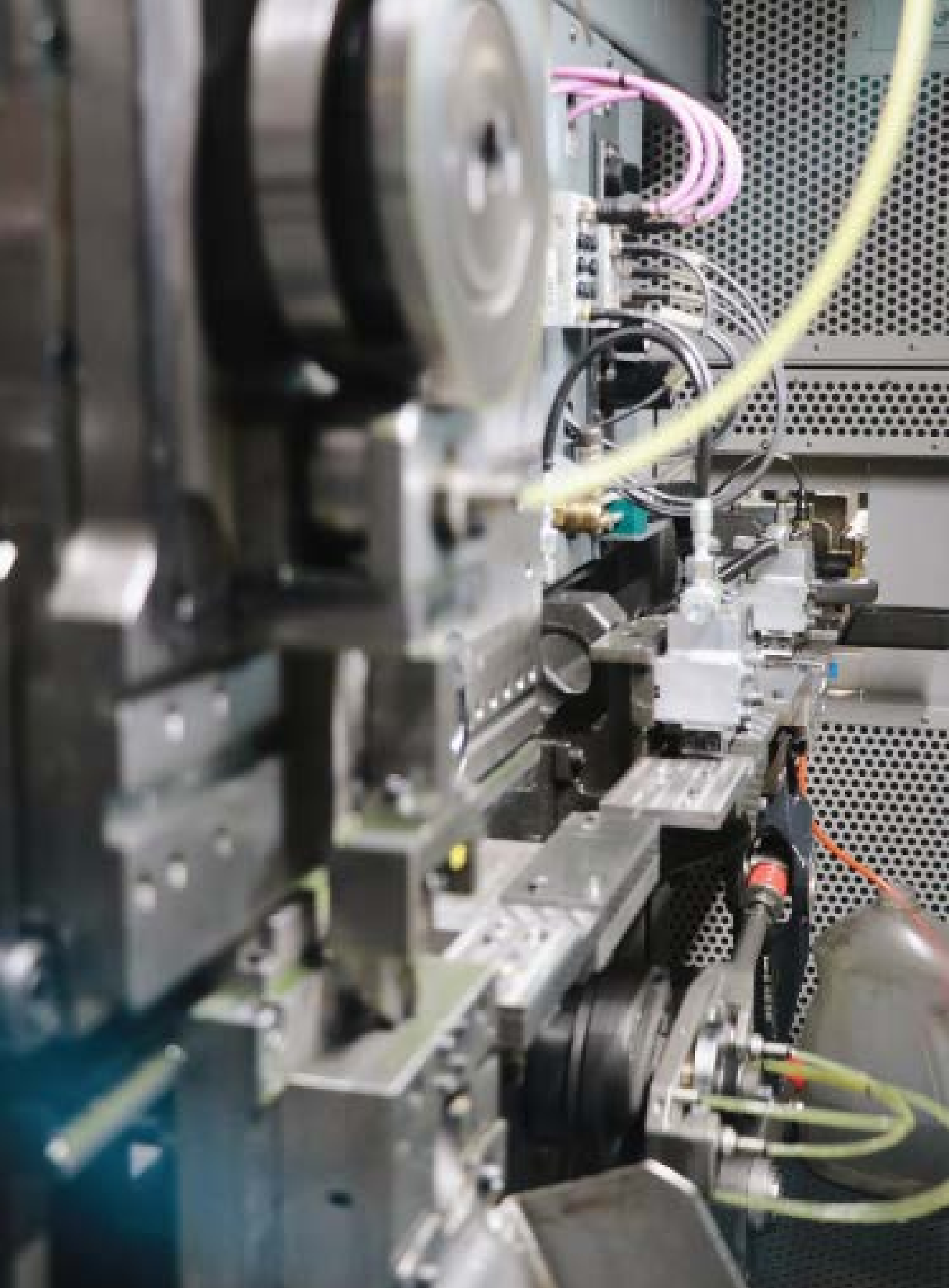



**RAAD**  <sup>®</sup> Electrical Connection for  
Technological Components  
*Confidence in Connection*

# Multi-Conductor Push-in Terminal Blocks

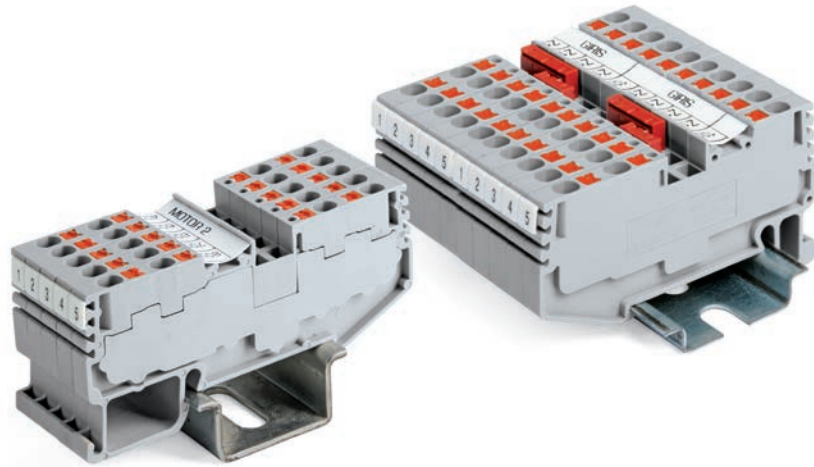

RAAD push-in multi-conductor terminal blocks offer the following advantages:

- In the RT/PG2.5-1/2 and RT/PG2.5-2/2 terminals, respectively, you can connect up to three and four wires in one terminal which will reduce the space occupied by the terminal strips.
- As for foot connection, RAAD push-in multi-conductor terminal blocks can be mounted on the TH35 mounting rail.
- Meet the specifications and strict requirements of IEC 60947-7-1 standard.
- RAAD multi-conductor push-in terminal blocks have a comprehensive range of accessories like, marking system, bridging screwless, and etc.
- High resistance to fire due to the use of PA materials.
- All terminal blocks are in accordance with the IEC 60947-7-1 standard.

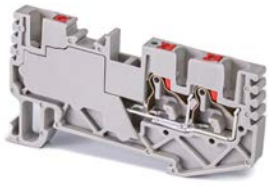

### RT/PG2.5-1/2

(RPIT2.5-1/2)

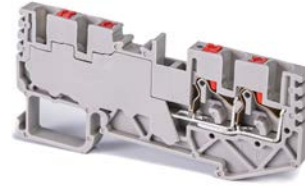

### RT/PG2.5-2/2

(RPIT2.5-2/2)

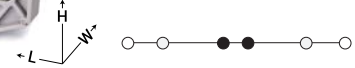

IEC 60947-7-1 rated data	RT/PG2.5-1/2	RT/PG2.5-2/2
Voltage (V)	800	800
Impulse voltage (kV)	8	8
Pollution degree/Voltage category/Material group	3/III/1	3/III/1
Current (A)	24	24
Cross-section (mm <sup>2</sup> )	2.5	2.5

Description	Type	Ordering No.	Qty.	Type	Ordering No.	Qty.
Terminal block, for mounting on TH 35-7.5, 15	RT/PG2.5-1/2	60110050	40	RT/PG2.5-2/2	6011006001	40
Partition	P-RPIT2.5-10 2	6020307001	50	P-RPIT2.5-10 2	6020307001	50
End bracket, width (mm) RAAD recommended for TH 35-7.5, 15	EB/4 8	6020101006	50	EB/4 8	6020101006	50
	EB/3 10	6020101003	50	EB/3 10	6020101003	50
	EB/1 9.5	6020101001	50	EB/1 9.5	6020101001	50
Bridge screwless	BS 10-2.5 10-pos. BS 3-2.5 3-pos. BS 2-2.5 2-pos.	6020505009 6020505002 6020505001	10 100 100	BS 10-2.5 10-pos. BS 3-2.5 3-pos. BS 2-2.5 2-pos.	6020505009 6020505002 6020505001	10 100 100
Marking Tags	NS5	For details see Accessories		NS5	For details see Accessories	
Marking Holder	Marking Holder	6032100001	10	Marking Holder	6032100001	10
Strip Lable	TBSL 22x20	For details see Accessories		TBSL 22x20	For details see Accessories	
Color (Color Code is the last 2 digits of the Ordering No.)	05   09					
<b>Dimensions (mm)</b>	<b>W / L / H</b>			<b>W / L / H</b>		
Width/Length/Height, TH 35-7.5	5.2/65.5/36			5.2/76.5/36		
Width/Length/Height, TH 35-15	5.2/65.5/43.5			5.2/76.5/43.5		
<b>Connection capacity</b>						
Rigid Solid (mm <sup>2</sup> )	0.5-4			0.5-4		
Rigid stranded (mm <sup>2</sup> )*	0.5-2.5			0.5-2.5		
Flexible (mm <sup>2</sup> )*	0.5-2.5			0.5-2.5		
American Wire Gauge (AWG)	20-12			20-12		
<b>IEC test gauge</b>	<b>A3</b>			<b>A4</b>		
Stripping length (mm)	12			12		
<b>Insulation material</b>	<b>PA</b>			<b>PA</b>		

\* Prepare this kind of cable with ferrule.





**RAAD**  <sup>®</sup> Electrical Connection for  
Technological Components

*Confidence in Connection*

# Disconnect Push-in Terminal Block

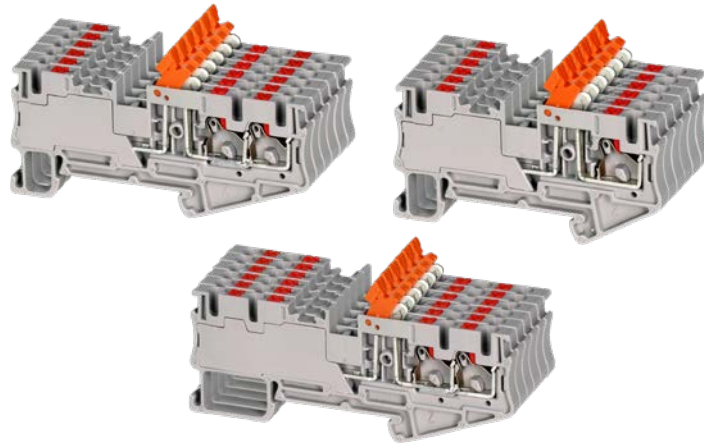

RAAD disconnect push-in terminal blocks offer the following advantages:

- This category of terminal blocks provides the features of both types of multi-conductor and disconnect terminal block for users.
- These type of terminals speed up wiring and can quickly and safely connect or disconnect the current path.
- In the RT/PG2.5-S-1/2 and RT/PG2.5-S-2/2 terminals, you can connect up to three and four connection in one terminal which will reduce the space occupied by the terminal strips.
- These terminal blocks are characterized by their flexible bridgeability and optimum marking options.
- The terminal blocks are flame retardant due to use PA materials.
- All terminal blocks are in accordance with the IEC 60947-7-1 standard.

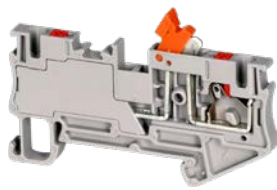

RT/PK2.5

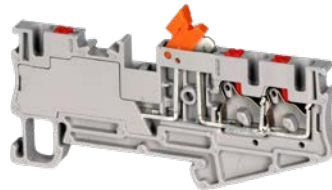
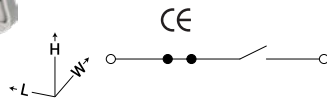

RT/PK2.5-1/2

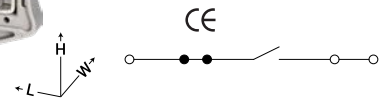

IEC 60947-7-1 rated data	RT/PK2.5	RT/PK2.5-1/2
Voltage (V)	400	400
Impulse voltage (kV)	6	6
Pollution degree/Voltage category/Material group	3/III/1	3/III/1
Current (A)	20	20
Cross-section (mm <sup>2</sup> )	2.5	2.5

Description	Type	Ordering No.	Qty.	Type	Ordering No.	Qty.
Terminal block, for mounting on TH 35-7.5, 15	RT/PK2.5	60116000	30	RT/PK2.5-1/2	60116000	30
Partition Width (mm)	P-RPIT2.5-10 2	6020307001	50	P-RPIT2.5-10 2	6020307001	50
End bracket, width (mm) RAAD recommended for TH 35-7.5, 15	EB/4 8	6020101006	50	EB/4 8	6020101006	50
	EB/3 10	6020101003	50	EB/3 10	6020101003	50
	EB/1 9.5	6020101001	50	EB/1 9.5	6020101001	50
Bridge screwless	BS 10-2.5 10-pos.	6020505009	10	BS 10-2.5 10-pos.	6020505009	10
	BS 3-2.5 3-pos.	6020505002	100	BS 3-2.5 3-pos.	6020505002	100
	BS 2-2.5 2-pos.	6020505001	100	BS 2-2.5 2-pos.	6020505001	100
Marking Tags	NS5	For details see Accessories		NS5	For details see Accessories	
Marking Holder	Marking Holder	6032100001	10	Marking Holder	6032100001	10
Strip Label	TBSL 22x20	For details see Accessories		TBSL 22x20	For details see Accessories	
Color (Color Code is the last 2 digits of the Ordering No.)		03   04			02   05	
<b>Dimensions (mm)</b>	<b>W / L / H</b>			<b>W / L / H</b>		
Width/Length/Height, TH 35-7.5	5.2/69.9/38.8			5.2/81.4/38.8		
Width/Length/Height, TH 35-15	5.2/69.9/46.3			5.2/81.4/46.3		
<b>Connection capacity</b>						
Rigid Solid (mm <sup>2</sup> )	0.5-4			0.5-4		
Rigid stranded (mm <sup>2</sup> )*	0.5-2.5			0.5-2.5		
Flexible (mm <sup>2</sup> )*	0.5-2.5			0.5-2.5		
American Wire Gauge (AWG)	20-12			20-12		
<b>IEC test gauge</b>	<b>A3</b>			<b>A3</b>		
Stripping length (mm)	12			12		
<b>Insulation material</b>	<b>PA</b>			<b>PA</b>		

\* Prepare this kind of cable with ferrule.

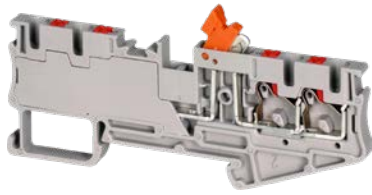







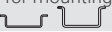

RT/PK2.5-2/2

CE



IEC 60947-7-1 rated data	RT/PK2.5-2/2
Voltage (V)	400
Impulse voltage (kV)	6
Pollution degree/Voltage category/Material group	3/III/I
Current (A)	20
Cross-section (mm <sup>2</sup> )	2.5

Description	Type	Ordering No.	Qty.
Terminal block, for mounting on TH 35-7.5, 15 	RT/PK2.5-2/2	60116000 	70
Partition Width (mm)	P-RPIT2.5-10 2	6020307001	50
End bracket, for TH 35-7.5, 15 width (mm) 	 EB/4 8 EB/3 10 EB/1 9.5	6020101006 6020101003 6020101001	50 50 50
Bridge screwless 	BS10-2.5 10-pos. BS3-2.5 3-pos. BS2-2.5 2-pos.	6020505009 6020505002 6020505001	10 100 100
Marking Tags 	NS5	For details see Accessories	
Marking Holder 	Marking Holder	6032100001	10
Strip Label 	TBSL 22x20	For details see Accessories	
Color (Color Code is the last 2 digits of the Ordering No.)	 01   06		
<b>Dimensions (mm)</b>	<b>W / L / H</b>		
Width/Length/Height, TH 35-7.5	5.2/93.3/38.8		
Width/Length/Height, TH 35-15	5.2/93.3/46.3		
<b>Connection capacity</b>			
Rigid Solid (mm <sup>2</sup> )	0.5-4		
Rigid stranded (mm <sup>2</sup> )*	0.5-2.5		
Flexible (mm <sup>2</sup> )*	0.5-2.5		
American Wire Gauge (AWG)	20-12		
<b>IEC test gauge</b>	<b>A3</b>		
Stripping length (mm)	12		
<b>Insulation material</b>	<b>PA</b>		

\* Prepare this kind of cable with ferrule.



**RAAD**  <sup>®</sup> Electrical Connection for  
Technological Components  
*Confidence in Connection*

# High current Terminal Blocks

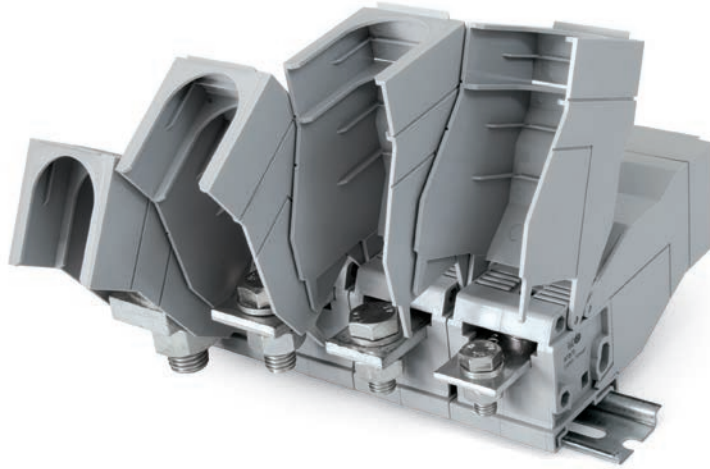

The RT/SH series of high current terminal blocks offer secure connections for all applications which involve a transmission of energy. RT/SH series have following characteristics:

- The connection ranges extended from 70mm<sup>2</sup> to 240mm<sup>2</sup>
- For voltage range up to 1000V and current up to 415A
- Self-extinguishing insulation material with high grade fire resistance
- Supplying special covers to avoid touching live parts
- Can be used with threaded studs M8 to M16, depending on the conductor cross-section
- Mountable on TH35-7.5, 15 rail in accordance with IEC 60715

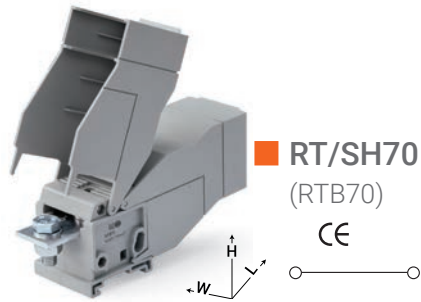

**RT/SH70**  
(RTB70)



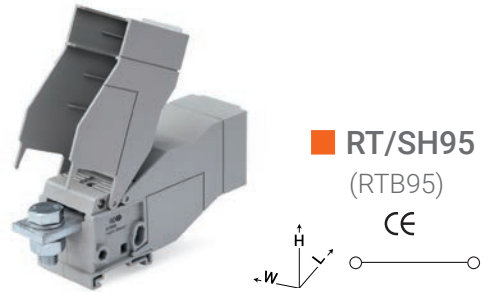



CE



**RT/SH95**  
(RTB95)

CE

IEC 60947-7-1 rated data	RT/SH70	RT/SH95
Voltage (V)	1000	1000
Impulse voltage (kV)	8	8
Pollution degree/Voltage category/Material group	3/III/1	3/III/1
Current (A)	192	232
Cross-section (mm <sup>2</sup> )	70	95

Description	Type	Ordering No.	Qty.	Type	Ordering No.	Qty.
Terminal block, for mounting on TH 35-7.5, 15 	RT/SH70	6010501002	5	RT/SH95	6010502002	5
End bracket, for TH 35-7.5, 15 width (mm) 	EB/4 8	6020101006	50	EB/4 8	6020101006	50
	EB/3 10	6020101003	50	EB/3 10	6020101003	50
	EB/2 10	6020101002	50	EB/2 10	6020101002	50
Cover	RT/SH70	6020803001	10	RT/SH95	6020803001	10
Marking Tags 	NS10	For details see Accessories		NS10	For details see Accessories	
Marking Holder 	Marking Holder	6032100001	10	Marking Holder	6032100001	10
Strip Label 	TBSL 22x20	For details see Accessories		TBSL 22x20	For details see Accessories	
Color						
<b>Dimensions (mm)</b>	<b>W / L / H</b>			<b>W / L / H</b>		
Width/Length/Height, TH 35-7.5	43/203/69.5			43/203/69.5		
Width/Length/Height, TH 35-15	43/203/77			43/203/77		
<b>Connection capacity</b>						
Cable lugs DIN 46234 (mm <sup>2</sup> )	2.5-70			6-95		
Cable lugs DIN 46235 (mm <sup>2</sup> )	16-70			16-95		
American Wire Gauge DIN 46234 (AWG)	14-2/0			10-3/0		
American Wire Gauge DIN 46235 (AWG)	6-2/0			6-3/0		
<b>Clamping screw</b>	<b>M8</b>			<b>M10</b>		
Hole diameter/Power rail	9/25 x 3			11/25 x 5		
Tightening torque (N.m)	15-20			25-30		
<b>Insulation material</b>	<b>PA</b>			<b>PA</b>		

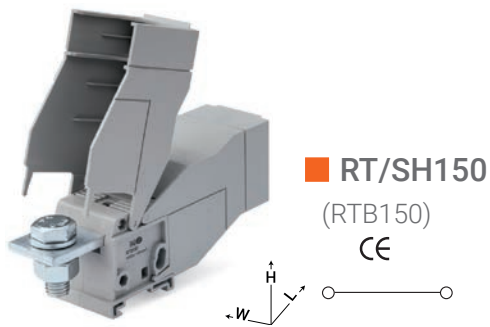

**RT/SH150**  
(RTB150)  
CE

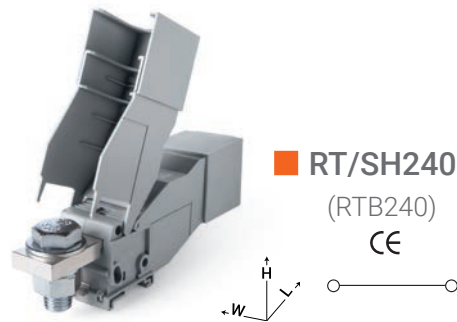

**RT/SH240**  
(RTB240)  
CE

IEC 60947-7-1 rated data	RT/SH150	RT/SH240
Voltage (V)	1000	1000
Impulse voltage (kV)	8	8
Pollution degree/Voltage category/Material group	3/III/I	3/III/I
Current (A)	309	415
Cross-section (mm <sup>2</sup> )	150	240

Description	Type	Ordering No.	Qty.	Type	Ordering No.	Qty.
Terminal block, for mounting on TH 35-7.5, 15	RT/SH150	6010503001	5	RT/SH240	6010504001	4
End bracket, for TH 35-7.5, 15 width (mm)	EB/4 8 EB/3 10 EB/2 10	6020101006 6020101003 6020101002	50 50 50	EB/4 8 EB/3 10 EB/2 10	6020101006 6020101003 6020101002	50 50 50
Cover	RT/SH150	6020803001	10	RT/SH240	6020803001	10
Marking Tags	NS10	For details see Accessories		NS10	For details see Accessories	
Marking Holder	Marking Holder	6032100001	10	Marking Holder	6032100001	10
Strip Label	TBSL 22x20	For details see Accessories		TBSL 22x20	For details see Accessories	
Color	■			■		
<b>Dimensions (mm)</b>	<b>W / L / H</b>			<b>W / L / H</b>		
Width/Length/Height, TH 35-7.5	43/203/69.5			43/253/69.5		
Width/Length/Height, TH 35-15	43/253/77			43/253/77		
<b>Connection capacity</b>						
Cable lugs DIN 46234 (mm <sup>2</sup> )	10-150			25-240 *		
Cable lugs DIN 46235 (mm <sup>2</sup> )	25-150			50-185 *		
American Wire Gauge DIN 46234 (AWG)	8-300 Kcmil			4-500 Kcmil		
American Wire Gauge DIN 46235 (AWG)	4-300 Kcmil			0-350 Kcmil		
<b>Clamping screw</b>	<b>M12</b>			<b>M16</b>		
Hole diameter/Power rail	13/30 x 5			17/29.7 x 9.7		
Tightening torque (N.m)	25-30			30-35		
<b>Insulation material</b>	<b>PA</b>			<b>PA</b>		

\*Cable Lugs for RT/SH 240 should be installed under the current bar.



**RAAD**  <sup>®</sup> Electrical Connection for  
Technological Components  
*Confidence in Connection*

# Transformer Terminal Blocks

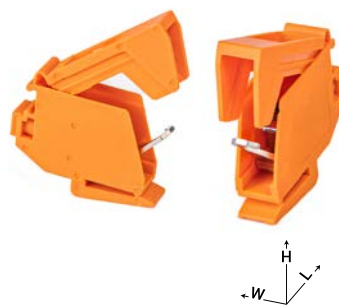

RAAD transformer terminal blocks (RT/TC4) has below characteristics:

- According with IEC60947-7-1
- Made of self-extinguishing material with flamability class V2
- Has fit insulating cover
- Easy marking
- No need special preparations

IEC 60947-7-1 rated data		RT/TC4 (RT4)	
Voltage(V)/Impulse voltage (KV)		800 / 6	
Pollution degree/ Voltage category/ Material group		3/III/I	
Current (A)		32	
Cross - section (mm <sup>2</sup> )		4	

Description	Type	Ordering No.	Qty.
Transformer terminal block	RT/TC4	6010499002	50
Marking Tags	1 2 3	NS6.4 For details see Accessories	
color		■	

Dimensions (mm)	
Width/Length	7.5/21.7

Connection capacity	
Rigid solid (mm <sup>2</sup> )	0.5-4
Rigid stranded (mm <sup>2</sup> )	0.5-4
Flexible (mm <sup>2</sup> )	0.5-4
American wire gauge (AWG)	20-12

IEC test gauge	
Striping length (mm)	9
Clamping screw	M2.5
Tightening torque (N.m)	0.6

Insulation material	
	PA



**RAAD**  <sup>®</sup> Electrical Connection for  
Technological Components  
*Confidence in Connection*

# Strip Terminal Block Series

The Strip terminals can be used for household and similar purposes, with direct mounting.

The RT/SS2.5 and RT/SS6 types have the benefit of double modules, "which can be mounted with any required strips by slide fitting."



- The specification that distinguishes RT/SS2.5 and RT/SS6 is their similar height that makes adjacent terminal blocks have the same height by tightening their bodies together.

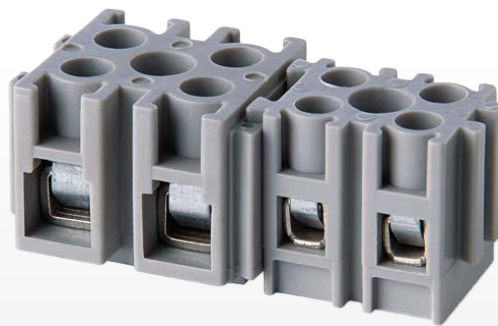



**RT/SS2.5**  
(RMT2.5)



**RT/SS6**  
(RMT6)



IEC 60947-7-1 rated data	RT/SS2.5	RT/SS6
Voltage (V)	500	750
Impulse voltage (kV)	6	8
Pollution degree/ Voltage category/Material group	3/III/1	3/III/1
Current (A)	24	41
Cross-section (mm <sup>2</sup> )	2.5	6

Description	Type	Ordering No.	Qty.	Type	Ordering No.	Qty.
Strip Terminals Block	RT/SS2.5	60101030 <span style="border: 1px solid black; padding: 0 2px;"> </span> <span style="border: 1px solid black; padding: 0 2px;"> </span>	100	RT/SS6	60101030 <span style="border: 1px solid black; padding: 0 2px;"> </span> <span style="border: 1px solid black; padding: 0 2px;"> </span>	60
Screw Driver	0.5x3.0	-	-	0.6x3.5	-	-
Marking Tags	NS6	For details see Accessories		NS6	For details see Accessories	
Color (Color Code is the last 2 digits of the Ordering No.)	<span style="display: inline-block; width: 10px; height: 10px; background-color: gray; border: 1px solid black;"></span> 01   <span style="display: inline-block; width: 10px; height: 10px; background-color: black; border: 1px solid black;"></span> 04			<span style="display: inline-block; width: 10px; height: 10px; background-color: gray; border: 1px solid black;"></span> 02   <span style="display: inline-block; width: 10px; height: 10px; background-color: black; border: 1px solid black;"></span> 05		
<b>Dimensions (mm)</b>	W / L / H			W / L / H		
Width/Length/Height,	14.7 / 21.4 / 17.8			21 / 25.5 / 17.8		
<b>Connection capacity</b>						
Rigid Solid (mm <sup>2</sup> )	0.5-4			0.5-10		
Rigid stranded (mm <sup>2</sup> )	0.5-4			0.5-10		
Flexible (mm <sup>2</sup> )	0.5-2.5			0.5-6		
American Wire Gauge (AWG)	20-12			20-8		
<b>IEC test gauge</b>	<b>A3</b>			<b>A5</b>		
Stripping length (mm)	10			12		
<b>Clamping screw/Tightening torque (N.m)</b>	<b>M2.5 / 0.4-0.6</b>			<b>M3.5 / 0.8-1.2</b>		
<b>Insulation material</b>	<b>PA</b>			<b>PA</b>		

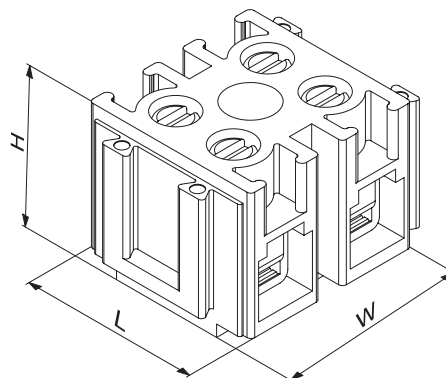
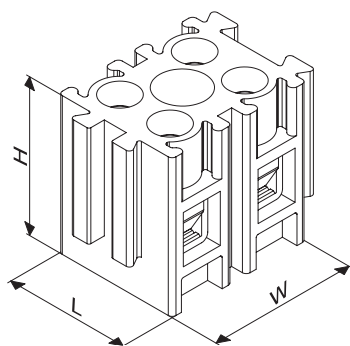





**RT/SS16**

(B16)



IEC 60998-2-1 rated data	RT/SS16
Voltage (V)	750
Impulse voltage (kV)	6
Pollution degree/ Voltage category /Material group	3/III/1
Current (A)	76
Cross-section (mm <sup>2</sup> )	16

Description	Type	Ordering No.	Qty.
Strip Terminals Block	RT/SS16/12	6010102008	8
	RT/SS16/10	6010102007	16
	RT/SS16/8	6010102006	24
	RT/SS16/6	6010102005	30
	RT/SS16/5	6010102004	32
	RT/SS16/4	6010102003	48
	RT/SS16/3	6010102002	32
	RT/SS16/2	6010102001	96
Screw Driver 	1.0x5.5	-	-
Color			
<b>Dimensions (mm)</b>			
Length/Height		26.5/26.2	
Width: 2pole		24.5	
3pole		39.5	
4pole		54.5	
5pole		69.5	
6pole		84.5	
8pole		114.5	
10pole		144.5	
12pole		175	
<b>Connection capacity</b>			
Rigid Solid (mm <sup>2</sup> )		0.5-16	
Rigid stranded (mm <sup>2</sup> )		0.5-16	
Flexible (mm <sup>2</sup> )		0.5-10	
American Wire Gauge (AWG)		20-6	
<b>IEC test gauge</b>			
		A5	
Stripping length (mm)		8.5	
<b>Clamping screw/Tightening torque (N.m)</b>			
		M5/2	
<b>Insulation material</b>			
		PA	

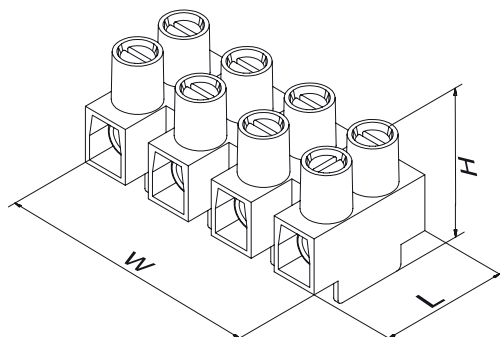

**RAAD**  <sup>®</sup> Electrical Connection for  
Technological Components

*Confidence in Connection*

# Splicing Connectors



- RAAD splicing connector series is the best choice for junction boxes, compact electrical devices, and LED light fixtures. RT/LH4 series have below characteristics:
- Convenient wiring via extremely compact design
- Easy to use and insertion of conductors
- Available in 2, 3 and 5 Poles
- specially designed for low-voltage installations (up to 450 V and up to 32A)
- providing safe and strength electrical and mechanical connections
- Continuous operating temperature from -20°C to 85°C
- Designed according to IEC 60998-1 requirements
- Test slot designed for measuring the connector voltage
- Transparent housing to assure proper insertion of conductors

IEC 60998-1 rated data		RT/LH4	
Voltage(V)/Impulse voltage (KV)		450/ 4	
Pollution degree/ Voltage category/ Material group		3/III/1	
Current (A)		32	
Cross section (mm <sup>2</sup> )		4	
Description	Type	Ordering No.	Qty.
Splicing Connector	RT/LH4-5 5-pos.	6011301005	50
	RT/LH4-3 3-pos.	6011301003	50
	RT/LH4-2 2-pos.	6011301002	50
Total number of connection points		2,3,5	
color		Transparent	
Dimensions (mm)			
Length/ Height		20.6/ 10.5	
Width: 2 pole/ 3 pole/ 5 pole		13/ 18.6/ 29.8	
Connection capacity			
Solid (mm <sup>2</sup> )		0.5-4	
Stranded (mm <sup>2</sup> )		0.5-4	
American wire gauge (AWG)		20-12	
Strip length (mm)		11	
IEC test gauge		A3	
Insulation material: body / lever		PC/ PA	
Flammability rating per UL 94		V2	
Weight (g): 2 pole/ 3 pole/ 5 pole		2.3/ 3.3/ 5	

**RAAD**  <sup>®</sup> Electrical Connection for  
Technological Components

*Confidence in Connection*

# Terminal Block Accessories

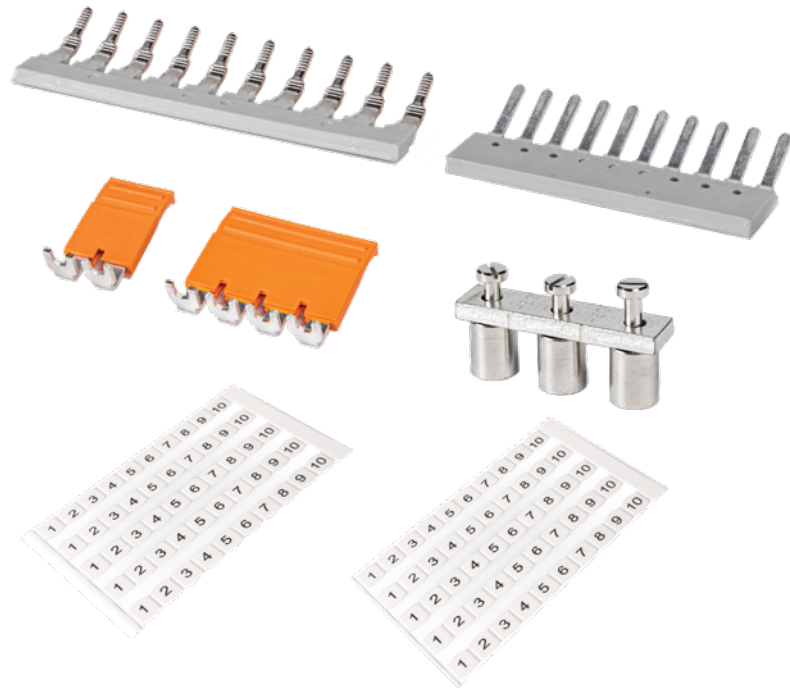

- Marking system
- End Plates, Partitions, and Cover Base
- End Brackets
- Test Accessories
- Cross-Connection

# Marking System

## Marking Tags

### The NS type Marking Tags

This type of labeling meets the advantage of easy and quick handling. The NS sheets consist of white polyamide with Laser engraving.

The sheets are labeled horizontally with maximum 3 characters, easy to read and high-contrast. The UV Laser technology engraving are completely wiping resistant. The NS sheets can be divided at any point and can be manually labeled with ease. Note that special engraving can be requested by customers. Samples of the NS sheets can be seen in the below picture.

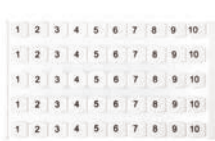

**NS 5**  
(width 5 mm)

RT/PG2.5 series  
RT/SG2.5 series



**NS 6**  
(width 6 mm)

RT/SU2.5 series  
RT/SK2.5 series  
RT/SG4 series  
RT/PG4 series  
RT/SS series



**NS 6.4**  
(width 6.4 mm)

RT/SU4 series

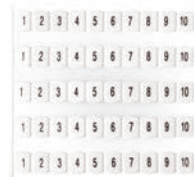

**NS 8**  
(width 8 mm)

RT/SU6 series  
RT/PG6 series  
RT/SG6 series  
RT/SF series  
RT/ST series



**NS 10**  
(width 10 mm)

RT/SU10 ... 150 series  
RT/SH series  
RT/PG10, 16 series  
RT/SG10 series  
DSO series

### Packing

The NS sheets are delivered in plastic bags and special box of 10 sheets=50 strips=500 single tags.

# Marking Carriers Group



■ LB/1



Description	Type	Ordering No.	Qty.	Material	Dimensions (W/H/L)(mm)
Group marking carrier, for mounting on TH 35- 7.5, 15  width (mm)	LB/1 18.5	6020102001	50	PA	din rail 7.5 : 18.5/48/44.5 din rail 15 : 18.5/55.5/44.5



■ LB/2



Description	Type	Ordering No.	Qty.	Material	Dimensions (W/H/L)(mm)
Group marking carrier, for mounting on TH 35- 7.5, 15  width (mm)	LB/2 9.5	6020102002	50	PA	din rail 7.5 : 9.5/48/44.5 din rail 15 : 18.5/55.5/44.5



■ ELB/1



Description	Type	Ordering No.	Qty.	Material	Dimensions (W/H/L)(mm)
Group marking carrier, for mounting on EB/1, EB/3 width (mm)	ELB/1 9.5	60201020	50	PA	9.5/22.5/43.5
Color (Color Code is the last 2 digits of the Ordering No.)					



■ ELB/4



Description	Type	Ordering No.	Qty.	Material	Dimensions (W/H/L)(mm)
Group marking carrier, for mounting on EB/4 width (mm)	ELB/4 8	6020101010	50	PA	8/31/46

## Marking Strip

### The Marking Strip

There is a special accessory called the marking holder which is designed for products that don't have a specific place to set up the strip in their bodies. In these products, Marking holder can be easily set on the body and a strip can be mounted in the marking holder.

In the following table, you can find the list of products that the marking strip can be applied.



■ Marking Holder

Ordering No. : 6032100001

- Screw terminal blocks:**  
 RT/SU2.5 , RT/SU2.5-H , RT/SU4  
 RT/SU6 , RT/SU10  
 RT/SU16 , RT/SU25  
 RT/SU35 , RT/SU50 , RT/SU70  
 RT/SU95 , RT/SU150  
 RT/SU4-2L , RT/SU2.5/4-2L  
 RT/SU2.5/4-2L-L
- RT/SH70 , RT/SH95  
 RT/SH150 , RT/SH240  
 RT/SK2.5 , RT/SU4-3L  
 RT/SK2.5-TS , DSO, DSO-LD  
 RT/ST6 , RT/ST6-L  
 RT/ST6-CMP , RSTP6

**Accessories:**  
 EB/1, EB/2, EB/3

## End Plates, Partitions, and Cover Base



### End Plate (EP)

In the last terminal of an assembled rail, the end plates should be used for safety and finger protection, especially when the terminal block has no insulated cover. In the below table, you can find the terminal blocks and their suitable end plates.

Type	Ordering No.	Application	Material	Qty.
EP-RTP2.5	6020202005	RT/SU2.5	PA	100
EP-RTP2.5H-10	6020202105	RT/SU2.5-H, RTSU4, RT/SU6, RT/SU10, RT/SK2.5-C, RT/SK2.5-CTS, RT/SK2.5-D, RT/SK2.5-R, RT/SK2.5-F, RT/SK2.5-FLD	PA	50
EP-RETN2.5-10	6020206001	RT/SU2.5-SO, RT/SU4-SO, RT/SU6-SO, RT/SU10-SO	PA	50
EP1-DRTP4	6020203002	RT/SU4-2L	PA	20
EP2-DRTP4	6020203003	RT/SU4-2L	PA	20
EP3-DRTP4	6020203004	RT/SU4-2L	PA	20
EP-DRTP2.5/4	6020203001	RT/SU2.5/4-2L, RT/SU2.5/4-2L-L	PA	20
EP-RT/SU10-2L	6020203020	RT/SU10-2L	PA	20
EP-RT/SU2.5-3L0E5	6020206002	RT/SU2.5-3L0E5	PA	20
EP-RSTT6	6020201003	RT/ST6-SHT, RT/ST6-SHT-L	PA	50
EP-RSTP6	6020201004	RSTP6	PA	50
EP-RSTN6	6020201006	RT/ST6-CMP	PA	50
EP-RT/SG2.5-10	6020206003	RT/SG2.5, RT/SG4, RT/SG6, RT/SG10	PA	50
EP-RT/SG2.5-10E	6020206004	RT/SG2.5-E, RT/SG4-E, RT/SG6-E, RT/SG10-E	PA	50
EP-RT/SG2.5-4-2L	6020203006	RT/SG2.5-2L, RT/SG4-2L, RT/SG2.5-2LE, RT/SG4-2LE	PA	20
EP-RT/SG2.5-4-2L2E	6020206005	RT/SG2.5-2L2E, RT/SG4-2L2E	PA	20
EP-RT/SF4-2L	6020207001	RT/SF4-2L, RT/SF4-2L-LD	PA	20

### Partition (P)



These Accessories have been designed to separate different terminal block groups. These accessories have bigger surfaces than the terminals and in case of using cross-connection groups, they should be used as a separator to maintain the required clearance and creepage distance.

Type	Ordering No.	Application	Material	Qty.
P-RTP2.5	6020301005	RT/SU2.5	PA	100
P-RTP2.5H-10	6020301105	RT/SU2.5-H, RT/SU4, RT/SU6, RT/SU10	PA	50
P-DRTP4	6020302001	RT/SU4-2L	PA	20

### Partition (P-RPIT2.5-10)



This partition is placed on the rail next to the RT/PG2.5-10 terminals and will increase the clearance and creepage distance between two groups of terminals with different voltage levels.

Type	Ordering No.	Application	Material	Qty.
P-RPIT2.5-10	6020307001	RPIT2.5, RPIT4, RPIT6, RPIT10, RPIT16, RPIT2.5-1/2, RPIT2.5-2/2	PA	100

## Small Partition (SP)



Space-saving partitions can be post-fitted between cross-connections for terminal blocks.

Type	Ordering No.	Application	Material	Qty.
SP-2.5-10	6020304001	RT/SU2.5, RT/SU2.5-H, RT/SU4, RT/SU6, RT/SU10	PA	100
SP-D4	6020304004	RT/SU4-2L	PA	100

## General Partition (GP)



These types of partitions serve for RT/SU16-50.

Type	Ordering No.	Application	Material	Qty.
GP	60203050 <span style="border: 1px solid black; padding: 0 2px;"> </span> <span style="border: 1px solid black; padding: 0 2px;"> </span>	RT/SU16, RT/SU25, RT/SU35, RT/SU50, RT/SU2.5/4-2L, RT/SU2.5/4-2L-L, RT/SU4-2L, RT/SU4-3L, RT/PG2.5-2L, RT/PG2.53L0E5, RT/PG4-2L, RT/PG4-2LE	PA	20

Color  
(Color Code is the last 2 digits  
of the Ordering No.)



## Cover Base (CB\1)



The Cover Base is used with a cover profile as protection from touching live parts of electrical components. This can be mounted on both TH-35 and G rail.

Type	Ordering No.	Material	Qty.
CB\1	6020802001	PA	10

# End Brackets

## End Brackets

These types of accessories are provided to keep tightly installed terminal blocks on the rail

EB/1



Ordering No.	Description	Qty.	Dimensions (W/H/L)(mm)	Material
6020101001	End bracket For mounting on TH35, adjustable with terminal NS marking	50	9.5 / 35 / 50.6	PA

EB/2



Ordering No.	Description	Qty.	Dimensions (W/H/L)(mm)	Material
6020101002	End bracket For mounting on G32 and TH35, adjustable with terminal NS marking	50	10 / 50 / 55.5	PA

EB/3



Ordering No.	Description	Qty.	Dimensions (W/H/L)(mm)	Material
60201010□□	End bracket For mounting on TH35, adjustable with terminal NS marking	50	10 / 42.8 / 45.6	PA

Color (Color Code is the last 2 digits of the Ordering No.)



EB/4

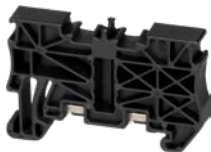

Ordering No.	Description	Qty.	Dimensions (W/H/L)(mm)	Material
60201010□□	End bracket For mounting on TH35, adjustable with terminal NS marking	50	8/41.8/53.5	PA/PC

Color (Color Code is the last 2 digits of the Ordering No.)



# Test Accessories

## Test Socket

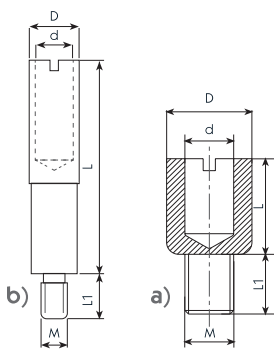

These types of accessories, are designed to give the possibility of current and voltage measurement in the electrical panel and are provided to keep tightly installed in the middle of terminal block busbar.

Type	Ordering No.	Drawing	L	L1	d	D	M	Application	Qty.
TS3/6/2.3	6020402001	a	6	3.5	2.3	4	3	RT/SU2.5, RT/SU4, RT/SU4-2L, RT/SU2.5-H, RT/SU4-3L, RT/SU2.5-3LOE5, RT/SU2.5/4-2L	50
TS3/8/4	6020402002	a	8	3.5	4	6	3	RT/SU10, RT/SU10 2L	50
TS3.5/8/4	6020402003	a	8	5	4	7	3.5	RT/SU16	50
TS4/8/4	6020402004	a	8	5	4	7	4	RT/SU25,35	50
TS6 Blue TS6 Yellow TS6 Gray TS6 Red TS6 Black TS6 Orange	6020401001 6020401004 6020401005 6020401006 6020401009 6020401010	b	26	4	4	5.5	3	RT/ST6, RT/ST6-L, RT/ST6-SHT, RT/ST6-SHT-L, RT/SU6	50

## Moveable Cross Connection (Link)

The moveable link, which is made of brass and has a polyamide insulation body, permits the current branching for the terminal block, functioning as a cross-connection, which makes a connection, and thus installed, can be also disconnected. It is used in test disconnect terminal blocks.

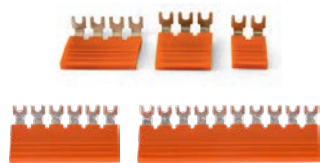

Type	Ordering No.	Application	Qty.
ML2N	6020602001	RT/ST6, RT/ST6-L, RT/ST6-SHT, RT/ST6-SHT-L	50
ML3N	6020602002	RT/ST6, RT/ST6-L, RT/ST6-SHT, RT/ST6-SHT-L	50
ML4N	6020602003	RT/ST6, RT/ST6-L, RT/ST6-SHT, RT/ST6-SHT-L	50
ML6N	6020602004	RT/ST6, RT/ST6-L, RT/ST6-SHT, RT/ST6-SHT-L	10
ML10N	6020602005	RT/ST6, RT/ST6-L, RT/ST6-SHT, RT/ST6-SHT-L	10

Type	Ordering No.	Application	Qty.
L2	6020501001	RT/ST6-CMP	50
L3	6020501002	RT/ST6-CMP	50
L4	6020501003	RT/ST6-CMP	50
L6	6020501004	RT/ST6-CMP	10
L10	6020501005	RT/ST6-CMP	10

# Cross-Connection



For the cross-connection bar, connection sleeves and screws are already captively mounted with the corresponding number of poles. The cross-connection then only requires inserting in the individual terminal row when fitting. The cross-connection unit is supplied in 2, 3 and 10 poles. Easy to cut the insulated body of terminal blocks with a nose plier or cutting tools to use rapidly jumping systems, is distinguished RAAD terminal blocks. This method can be used for types: RT/ST6, RT/ST6-SHT, RT/SU4-3L,...

## Screw Cross-Connection Bar(CC)



To handle cross-connection of several terminal blocks, with the same potential, copper cross-connection bars are used. These cross-connection bars supplied in 2, 3 and 10 poles; and their length are equal to the individual terminal width. The cross-connection bar is electrically joined through a connection sleeve to the terminal block busbar.

The length of the brass connection sleeve is matched to the individual terminal. In order to be able to connect the cross-connection bar and the connection sleeve to a terminal block busbar, a brass screw is applied. The cross-connections are designed so that where a terminal does not need any cross-connection; it is possible to remove the screw and its sleeve, thus no cross-connection occurs in the terminal.

Type	Ordering No.	Max. Current (A)	Application	Qty.
CC10-2.5	6020502009	24	RT/SU2.5, RT/SU2.5-H, RT/SU2.5/4-2L RT/SU2.5-3LOE5	10
CC3-2.5	6020502002			50
CC2-2.5	6020502001			50
CC10-4	6020502109	32	RT/SU4	10
CC3-4	6020502102			50
CC2-4	6020502101			50
CC10-D4	6020503009	32	RT/SU4-2L, RT/SU4-3L	10
CC3-D4	6020503002			50
CC2-D4	6020503001			50
CC10-6	6020502209	41	RT/SU6, RT/ST6, RT/ST6-L, RT/ST6-SHT, RT/ST6-SHT-L, RT/ST6-CMP	10
CC3-6	6020502202			50
CC2-6	6020502201			50
CC10-10	6020502309	57	RT/SU10, RT/SU10-2L	10
CC3-10	6020502302			50
CC2-10	6020502301			50
CC10-16	6020502409	76	RT/SU16	10
CC3-16	6020502402			20
CC2-16	6020502401			20
CC10-25	6020502419	101	RT/SU25	10
CC3-25	6020502412			20
CC2-25	6020502411			20
CC10-35	6020502439	114*	RT/SU35	10
CC3-35	6020502432			20
CC2-35	6020502431			20
CC3-50	6020502452	132**	RT/SU50	10
CC2-50	6020502451			10
CC2-70	6020502472	132	RT/SU70	10
CC3-70	6020502471			10
CC3-95	6020502492	200***	RT/SU95	10
CC2-95	6020502491			10
CC2-150	6020502511	250	RT/SU150	10
CC3-150	6020502512			10

\* In accordance with IEC/EN 60947-7-1, 124 A is recommended and in accordance with IEC/EN 60079-7, 114 A is recommended

\*\* In accordance with IEC/EN 60947-7-1, 140 A is recommended and in accordance with IEC/EN 60079-7, 132 A is recommended

\*\*\* In accordance with IEC/EN 60947-7-1, 210 A is recommended and in accordance with IEC/EN 60079-7, 200A is recommended

## Bridge Comb (BC)



This type of cross connection is consisted of plastic (PA) and copper parts and meet the best connection between the same voltage level of various terminal blocks, needing no special tools. This type of cross-connection in 2, 3, 10 branches/poles are available based on request.

Type	Ordering No.	Max. Current (A)	Application	Qty.
BC 10-2.5	6020504009	24	RT/SU2.5, RT/SU2.5-H, RT/SU2.5-2L, RT/SU2.5-2L-L, RT/SK2.5, RT/SK2.5-R, RT/SK2.5-D, RT/SK2.5-F, RT/SK2.5-FLD, RT/SU2.5-3L0E5	10
BC 3-2.5	6020504002			50
BC 2-2.5	6020504001			50
BC10-4	6020504109	32	RT/SU4, RT/SU4-2L, RT/SU4-3L, RT/SG4, RT/SG4-2L	10
BC3-4	6020504102			50
BC2-4	6020504101			50
JEB10-6	6020506009	41	RT/SU6, RT/ST6, RT/ST6-L, RT/ST6-SHT, RT/ST6-SHT-L, RSTP6, RT/ST6-CMP, RT/SF4, RT/SF4-LD, RT/SG6, RT/SF4-2L, RT/SF4-2L-LD	10
JEB3-6	6020506002			50
JEB2-6	6020506001			50

## Bridge Screwless (BS)



Confidence in connection attained by using copper for metal parts of BS. This type of jumpers can be used for RAAD screwless terminal block types: RT/PG.

Type	Ordering No.	Max. Current (A)	Application	Qty.
BS 10-2.5	6020505009	20*	RT/PG2.5, RT/PG2.5 - 2L, RT/PG2.5-3L0E5, RT/PG2.5 - 1/2, RT/PG2.5 - 2/2, RT/SG2.5, RT/SG2.5-2L	10
BS 3-2.5	6020505002			50
BS 2-2.5	6020505001			50
BS 10-4	6020505109	26**	RT/PG4, RT/PG4-2L, RT/SG4, RT/SG4-2L	10
BS 3-4	6020505102			50
BS 2-4	6020505101			50
BS 10-6	6020505209	41	RT/PG6, RT/SG6, RT/SF4-2L, RT/SF4-2L-LD	10
BS 3-6	6020505203			50
BS 2-6	6020505201			50
BS 3-10	6020505302	57	RT/PG10, RT/SG10	10
BS 2-10	6020505301			10
BS 2-16	6020505401	76	RT/PG16	10

\* In accordance with IEC/EN 60947-7-1, 24 A is recommended and in accordance with IEC/EN 60079-7, 20A is recommended.

\*\* In accordance with IEC/EN 60947-7-1, 32 A is recommended and in accordance with IEC/EN 60079-7, 26A is recommended.



**RAAD**  <sup>®</sup> Electrical Connection for  
Technological Components  
*Confidence in Connection*

# Din Rail Socket Outlet



The capability of RAAD Din Rail Socket Outlet (DSO) in mounting on din rails as well as its standard format, distinguished this type of product.

The main connection terminals (L1, N, PE) are arranged on one side of the socket for easy connection.

The advantages of DSO are as follows:

- Mountable on TH35-15 and TH35-7.5 din rails in accordance with IEC/EN 60715.
- Having three connection terminals: Phase-Neutral-Earth
- With and without light indicator (LED)
- Applied UL 94 high grade fire-resistant plastic material.
- The sockets are supplied with Marking Tags.



DSO

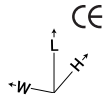

DSO-LD

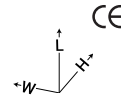

IEC 60884-1 rated data	DSO	DSO-LD
voltage (V)	250	250
Current (A)	16	16

Description	Type	Ordering No.	Qty.	Type	Ordering No.	Qty.
Terminal block, for mounting on TH 35-7.5, 15	DSO	60801010	5	DSO-LD	60802010	5
Marking Tags	NS10	For details see Accessories		NS10	For details see Accessories	
Color (Color Code is the last 2 digits of the Ordering No.)						

Dimensions (mm)	W / L / H	W / L / H
Width/Length/Height, TH 35-7.5	45.5/76/67.5	45.5/76/67.5
Width/Length/Height, TH 35-15	45.5/76/75	45.5/76/75
Connection capacity		
Rigid Solid (mm <sup>2</sup> )	0.5-10	0.5-10
Rigid stranded (mm <sup>2</sup> )	0.5-10	0.5-10
Flexible (mm <sup>2</sup> )	0.5-6	0.5-6
Clamping screw	M3.5	M3.5
American Wire Gauge (AWG)	20-8	20-8
stripping length (mm)	12	12
Tightening torque (N.m)	1.2	1.2
Degree of Protection	IP 20	IP 20
Insulation material	PA	PA

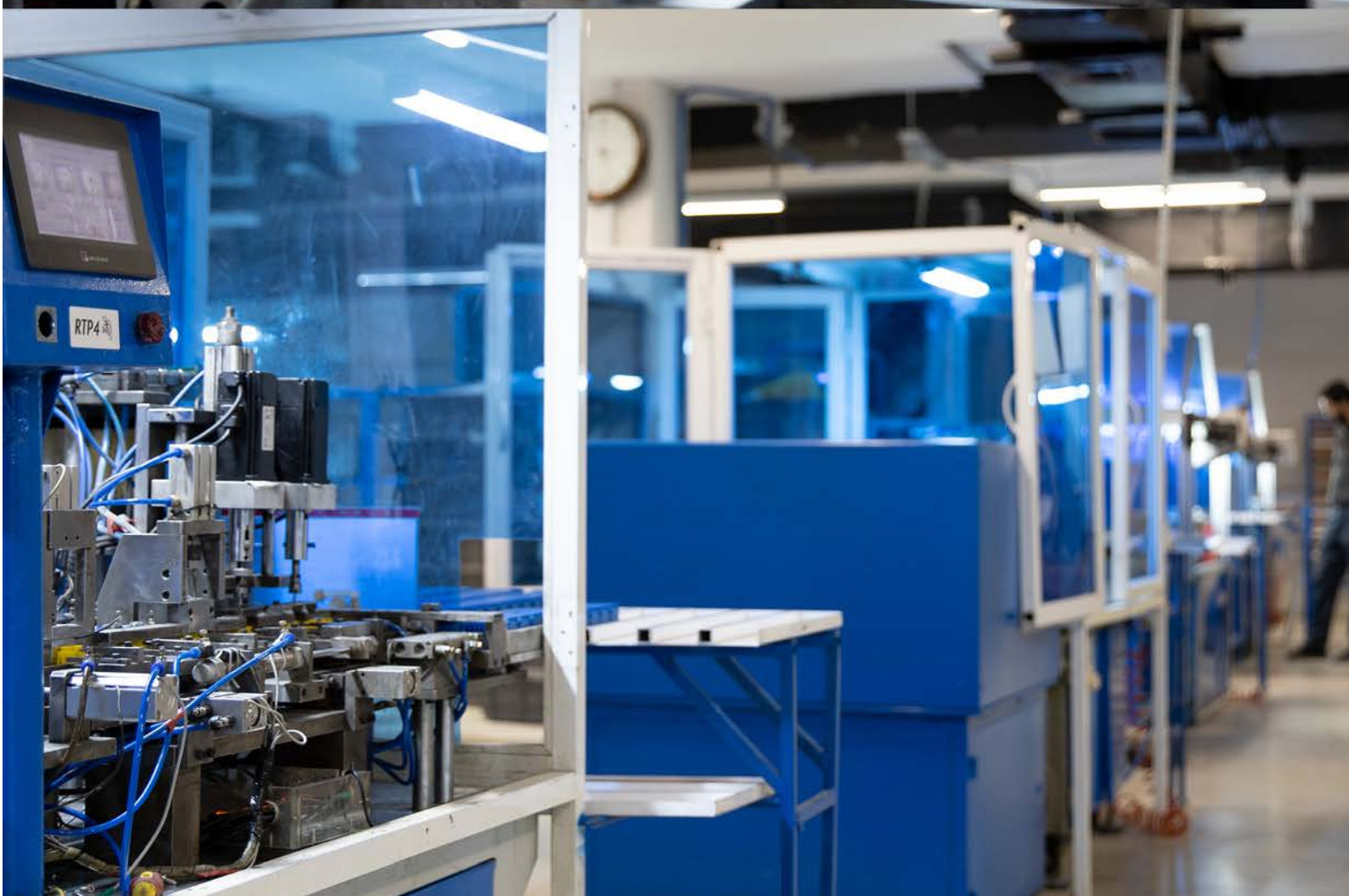

**RAAD**  <sup>®</sup> Electrical Connection for  
Technological Components

*Confidence in Connection*

# Switch Disconnectors



## Definition

Switch 

mechanical switching device capable of making, carrying and breaking currents under normal circuit conditions which may include specified operating overload conditions and also carrying for a specified time currents under specified abnormal circuit conditions such as those of short circuit

Disconnecter 

Mechanical switching device which, in the open position, complies with the requirements specified for the isolating function.

Compliance to international standards, any maintenance operations on installation are prohibited unless circuits have been previously disconnected.

Fuse-disconnector 

Disconnecter in which a fuse-link or fuse-carrier with fuse-link forms the moving contact. Refer to this definition not all of the fuse holders are disconnecter, so they must meet the requirements of IEC60947-3 standard.

Fuse-switch-disconnector 

Switch-disconnector in which a fuse-link or fuse-carrier with fuse-link forms the moving contact. Refer IEC 60947-3 standard definition, and utilization category of AC22-B identified in table 2, a fuse-switch-disconnector with these characteristics can be switched under load.

# Characteristics

- Due to AC-22 utilization category, according to IEC60947-3 standard, RB1 and RFH10 is designed for switching under load.

IEC 60947-3 Utilization Categories			
Nature of current	Utilization categories		Typical applications
	Category A	Category B	
Alternating current	AC-20A <sup>a</sup>	AC-20B <sup>a</sup>	<ul style="list-style-type: none"> <li>• Connecting and disconnecting under no-load conditions</li> <li>• Switching of resistive loads including moderate overloads</li> <li>• Switching of mixed resistive and inductive loads, including moderate overloads</li> </ul>
	AC-21A	AC-21B	
	AC-22A	AC-22B	
Direct current	AC-23A	AC-23B	<ul style="list-style-type: none"> <li>• Switching of motor loads or other highly inductive loads</li> </ul>
	DC-20A <sup>a</sup>	DC-20B <sup>a</sup>	<ul style="list-style-type: none"> <li>• Connecting and disconnecting under no-load conditions</li> <li>• Switching of resistive loads including moderate overloads</li> <li>• Switching of mixed resistive and inductive loads, including moderate overloads (e.g. shunt motors)</li> <li>• Switching of highly inductive loads (e.g. series motors)</li> </ul>
	DC-21A	DC-21B	
	DC-22A	DC-22B	
DC-23A	DC-23B		

- The RB/I and RFH10 can be used in automation switchboards for switching of mixed resistive and inductive loads. The protection of control circuits, primary and secondary of transformers, motors and other resistive or inductive loads is advantages of using RFH10.

## Switch-disconnector (ISOLATOR) RB/I

Switch-disconnector (isolator) is applicable to all buildings and all industrial command and control circuits. They can be used as the master switch of terminal apparatus. This product does not provide any protection and is only used to isolate the circuit.

RAAD Switch-disconnectors have the utilization category AC-22A type and are suitable for switching mixed resistive and inductive loads, including moderate overloads.

RAAD Isolators are produced in two types of 1P and 3P with nominal currents from 32A to 63A.

Rated short-time withstands current (I<sub>cw</sub>) in RAAD Isolators are 12I<sub>e</sub> for 1 second.

The electrical and mechanical life of RAAD Isolators are 2,000 and 10,000 cycles, respectively.

RAAD Isolators are made in full compliance with the international standard IEC 60947-3.

All Isolators have a unique hologram for the product's authenticity and a text message number informing the customer.



RAAD isolator product selection guide is shown below:

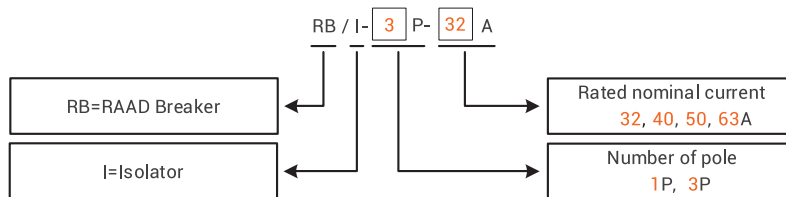



■ RB/I-1P  
CE



■ RB/I-3P  
CE

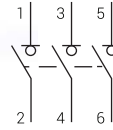

Technical data	RB/I-1P	RB/I-3P
Pole	1P	3P
Rated voltage Ue (V)	230/400	400
Rated current Ie (A)	16,20,25,32, 40, 50, 63	

IEC 60947-3 rated data	
Insulation voltage Ui (V)	500
Rated frequency (Hz)	50/60
Rated short-time withstand current I <sub>sc</sub>	12I <sub>e</sub> , t=1s
Rated making and breaking capacity	3I <sub>e</sub> , 1.05U <sub>e</sub> , cosφ=0.65
Rated short circuit making capacity	20I <sub>e</sub> , t=0.1s
Utilization category	AC-22A
Rated impulse withstand (kV)	4
Dielectric voltage for 1 minute (kV)	2
Mechanical Features	
Electrical life (Cycles)	2,000
Mechanical life (Cycles)	10,000
Protection degree	IP20
Installation	
Terminal connection type	Cable, Pin- type busbar, U- type busbar
Connection capacity for cable/busbar (mm <sup>2</sup> )	0.75 - 50
Connection capacity for cable/busbar (AWG)	18 - 2
Striping length (mm)	16
Tightening torque (N.m)	3.5
Mounting	DIN 35 (according IEC 60715)
Connection	Power supply from top and bottom

Overall and Installation Dimension (mm) :

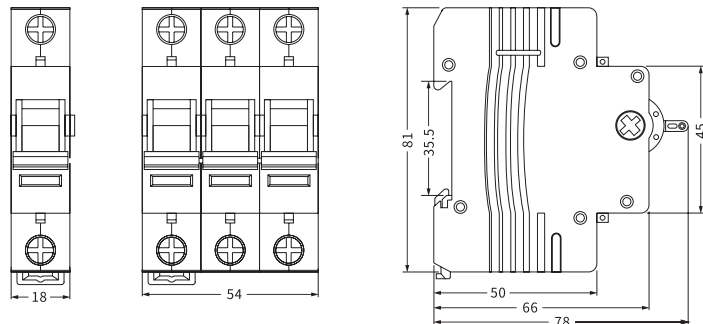

# Fuse-Switch-Disconnecter



RAAD fuse switch-disconnector introduces a new level of safety, special for 10.3x38, AC fuses.

The design of RAAD fuse- holders, in compliance with the IEC 60947-3 standard, has distinguished this type of product for switching under load, to ensure protection from any undesirable damaging currents.

RFH10, is mountable on TH 35-15, TH 35-7.5 DIN rails in accordance with IEC60715 and make high level of finger touch protection, while changing fuses.

Utilization of durable self-extinguish thermoplastic material with extra resistance to high current in body of RFH10 and on the other hand silver plated copper for its contact is strong proof to evidence the quality of this product.

RAAD fuse holders are available in 1, 2, 3 or 4 poles; with or without LED-indicator.

## Easy installing and high level of protection

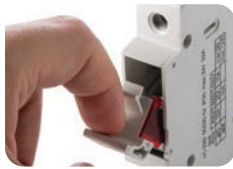

The design of RFH10 is space-saving and allows you to easily insert or replace fuses by flipping the hinge of knob.

RFH10 has a safe design for finger-touch protection and not accessible to live parts, in accordance with international protection standards.

Detecting the defective phase and blown fuses is simply achieved by indicator light LED



RAAD isolator product selection guide is shown below:

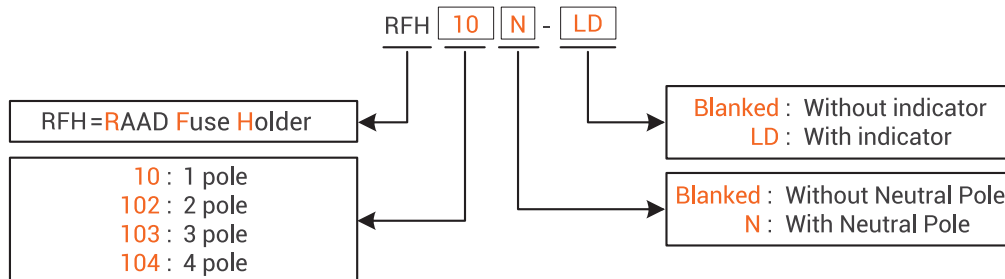



RFH10-LD

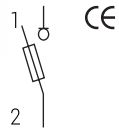

RFH103

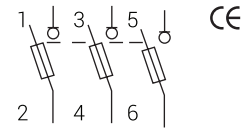

Technical data	RFH10					
Pole	1P	2P	3P	4P	1P+N	3P+N
Qty.	12	6	4	3	6	3
Rated operational voltage Ue (V)	690					
Rated operational current Ie (A)	32					
IEC 60947-3 rated data						
Insulation voltage Ui (V)	690					
Rated frequency (Hz)	50					
Rated impulse withstand (kV)	6					
Method of operation	Manual					
Utilization category	AC-22B 500V					
Rated conditional short circuit	100kA at 400V					
Over voltage category	III					
Kind of protective device	10.3x38 cylindrical fuse-link					
Maximum rated current of fuse links	690V	10A gG				
	500V	25A gG / 16A aM				
	400V	32A gG				
Max power dissipation of fuse-link (W)	gG: 3 aM: 1.2					
Insulation material	PA					
Protection degree	IP 20					
Indicator status	With LED Without LED					
Installation						
Terminal connection type	Cable, Pin- type busbar					
Connection capacity for cable/busbar (mm <sup>2</sup> )	0.5 - 16					
Connection capacity for cable/busbar (AWG)	20 - 6					
Striping length (mm)	12.3					
Tightening torque (N.m)	2.5					
Mounting	DIN 35 (according IEC 60715)					
Connection	Power supply from top and bottom					

Overall and Installation Dimension (mm) :

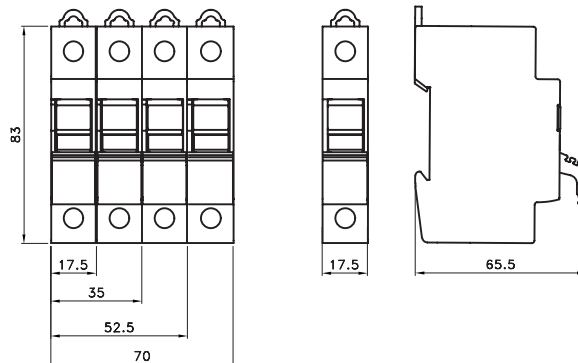



Rated operational voltage(v)	Rated Current (A)	Type	Dimension B(mm)	Ordering No.	Indicator	Qty.
690	32	RFH10	17.5	6050101001	-	12
		RFH10-LD		6050201001	LED	12

1 - Pole



Rated operational voltage(v)	Rated Current (A)	Type	Dimension B(mm)	Ordering No.	Indicator	Qty.
690	32	RFH10N	35	6050102001	-	6
		RFH10N-LD		6050202001	LED	6

1 - Pole+N



Rated operational voltage(v)	Rated Current (A)	Type	Dimension B(mm)	Ordering No.	Indicator	Qty.
690	32	RFH102	35	6050101002	-	6
		RFH102-LD		6050201002	LED	6

2 - Pole



Rated operational voltage(v)	Rated Current (A)	Type	Dimension B(mm)	Ordering No.	Indicator	Qty.
690	32	RFH103	52.5	6050101003	-	4
		RFH103-LD		6050201003	LED	4

3 - Pole



Rated operational voltage(v)	Rated Current (A)	Type	Dimension B(mm)	Ordering No.	Indicator	Qty.
690	32	RFH103N	70	6050102003	-	3
		RFH103N-LD		6050202003	LED	3

3 - Pole+N



Rated operational voltage(v)	Rated Current (A)	Type	Dimension B(mm)	Ordering No.	Indicator	Qty.
690	32	RFH104	70	6050101004	-	3
		RFH104-LD		6050201004	LED	3

4 - Pole



**RAAD**  <sup>®</sup> Electrical Connection for  
Technological Components

*Confidence in Connection*

# Circuit Protection



Low voltage circuit breakers (below 1000 volts) are used to protect circuits (lighting installations, industrial electricity, wires and cables, machineries, etc.) against overloads, short circuit faults and leakage currents.

These circuit breakers are used in industry, household, and similar installations. In the following, we will introduce some of them which are among the products of RAAD Company:

- One of the most widely used circuit breakers is the MCB. This type of circuit breaker protects circuits against overloads and short-circuits. MCBs produce in the nominal current range from 1A to 63 A.
- Another type of circuit breaker is called RCCB which protects life from the risk of electric shock and prevents leakage current in the electrical circuits. These circuit breakers are divided into two types in terms of sensitivity: the household type protects operators from direct or indirect electrical contact, and the industrial type protects industrial devices and equipment by preventing leakage current effectively.
- RCBOs are another type of circuit breakers that protect against overload, short circuits, and leakage currents simultaneously.

# AC Miniature Circuit Breaker (AC-MCB)

## RB/M

AC-miniature circuit breaker (MCB) is used in the electrical circuits to protect equipment and circuits against overload or short-circuit faults.

RAAD AC-MCBs are available in rated currents from 1A to 63A as well as curves B, C, and D for different applications.

RAAD AC-MCBs are manufactured in 1P, 1P+N, 2P, 3P, 3P+N, and 4P types.

The design for the interior and the body of RAAD MCBs are aimed to easily withstand short circuit current in both 6KA and 10KA.

RAADs MCBs can install two types of auxiliary contacts (RB-CB and RB-FB) for better use in circuits.

The design and adjustment of AC-MCBs produced by this company follow all the test clauses of the international standard IEC 60898-1, and all MCBs have product approval and certification. Based on the Tripping Characteristics, RAAD AC-MCB is available in B, C, and D curves to suit different applications. The figure and table below show the thermal and magnetic tripping characteristics of AC-MCB according to IEC 60898-1.

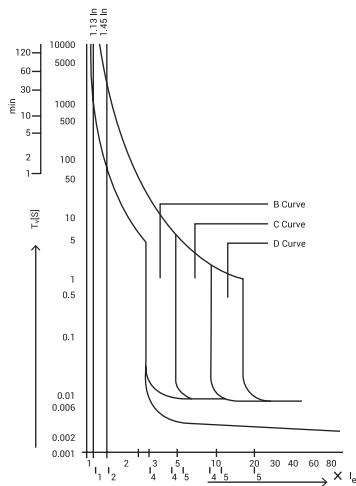

As per IEC 60898	Thermal Tripping			Magnetic Tripping		
	No tripping current $I_1$	Tripping current $I_2$	Time Limits $t$	Hold current $I_4$	Trip current $I_5$	Time Limits $t$
B Curve	$1.13 \times I_e$		$\geq 1h$	$3 \times I_e$		$\geq 0.1s$
			$< 1h$			$5 \times I_e$
C Curve	$1.13 \times I_e$		$\geq 1h$	$5 \times I_e$		$\geq 0.1s$
			$< 1h$			$10 \times I_e$
D Curve	$1.13 \times I_e$		$\geq 1h$	$10 \times I_e$		$\geq 0.1s$
			$< 1h$			$20 \times I_e$

RAAD AC-MCB product selection guide is shown below:

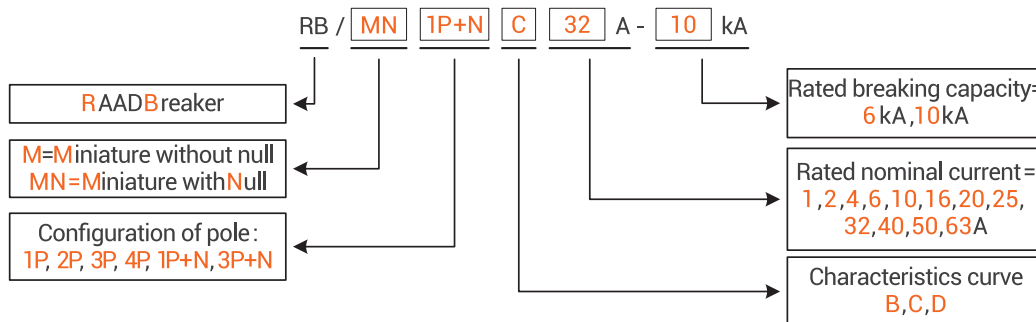

All RAAD MCBs have a unique hologram for the product's authenticity and a text message number informing the customer.





RB/M

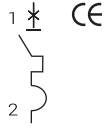

RB/MN

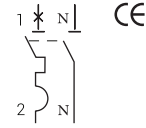

Technical data	RB/M				RB/MN	
Pole	1P	2P	3P	4P	1P+N	3P+N
Qty.	12	6	4	3	6	3
Rated voltage Ue (V)	230/400	400	400	400	230/400	400
Rated current Ie (A)	1, 2, 4, 6, 10, 16, 20, 25, 32, 40, 50, 63					

IEC 60898-1 rated data	
Insulation voltage Ui (V)	500
Rated frequency (Hz)	50
Rated breaking capacity Icu (kA)	6, 10
Energy limiting class	3
Rated impulse withstand Uimp (kV)	4
AC dielectric test voltage for 1 minute (kV)	2
Thermo-magnetic release characteristic	B (3×Ie - 5×Ie)
	C (5×Ie - 10×Ie)
	D (10×Ie - 20×Ie)
Reference temperature for setting thermal element (°C)	30
Ambient temperature (°C) (daily averages ≤ 35 °C)	-5 ~ +40
Storage temperature (°C)	-25 ~ +70

Mechanical Features	
Electrical life (Cycles)	8000
Mechanical life (Cycles)	20000
Protection degree	IP20

Installation	
Terminal connection type	Cable, Pin- type busbar, U- type busbar
Connection capacity for cable/busbar (mm <sup>2</sup> )	0.75 - 25
Connection capacity for cable/busbar (AWG)	18 - 3
Striping length (mm)	12
Tightening torque (N.m)	2.5
Mounting	DIN 35 (according IEC 60715)
Connection	From top and bottom

Accessories	Type	Ordering No.	Qty.
Auxiliary contact	RB/M-CB	6124001101	12
Alarm contact	RB/M-FB	6124101101	12

Overall and Installation Dimension (mm) :

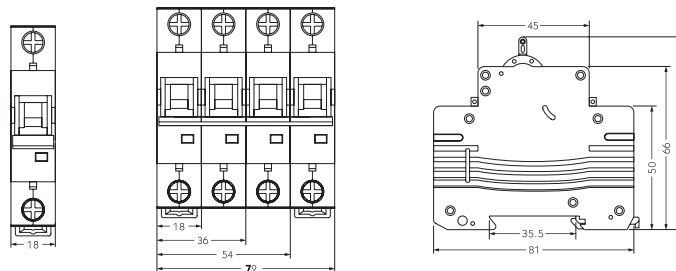

# DC Miniature Circuit Breaker (DC-MCB)

## RB/MD

DC-miniature circuit breaker (MCB) is used in direct current electrical circuits to protect equipment and circuits against DC overload or DC short-circuit faults.

RAAD DC-MCBs are available in rated currents from 1A to 63A for different applications like photovoltaic and DC distribution systems. RAAD DC-MCBs are in 1P and 2P types.

The design for the interior and the body of the of RAAD DC-MCBs are aimed to easily withstand short circuit currents in both 6KA and 10KA.

The design and adjustment of DC-MCBs produced by this company follow all the test clauses of the international standard IEC 60947-2, and all DC-MCBs have product approval and certification.

Based on the Tripping Characteristics, RAAD DC-MCB is available in B and C curves to suit different applications. The figure and table below show the thermal and magnetic tripping characteristics of DC-MCB according to IEC 60947-2.

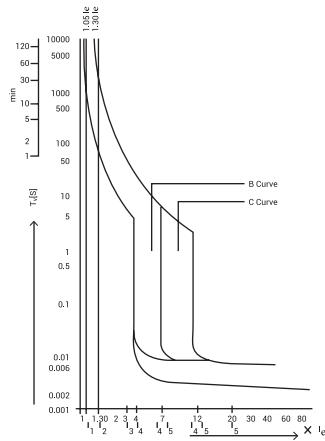

As per IEC 60947- 2	Thermal Tripping		Magnetic Tripping			
	No tripping current	Tripping Current $I_2$	Time Limits $t$	Hold current $I_4$	Trip current $I_5$	Time Limits $t$
B Curve	$1.05 \times I_e$	$1.30 \times I_e$	$\geq 1h$	$4 \times I_e$	$7 \times I_e$	$\geq 0.1s$
			$< 1h$			$< 0.1s$
C Curve	$1.05 \times I_e$	$1.30 \times I_e$	$\geq 1h$	$7 \times I_e$	$12 \times I_e$	$\geq 0.1s$
			$< 1h$			$< 0.1s$

RAAD DC-MCB product selection guide is shown below:

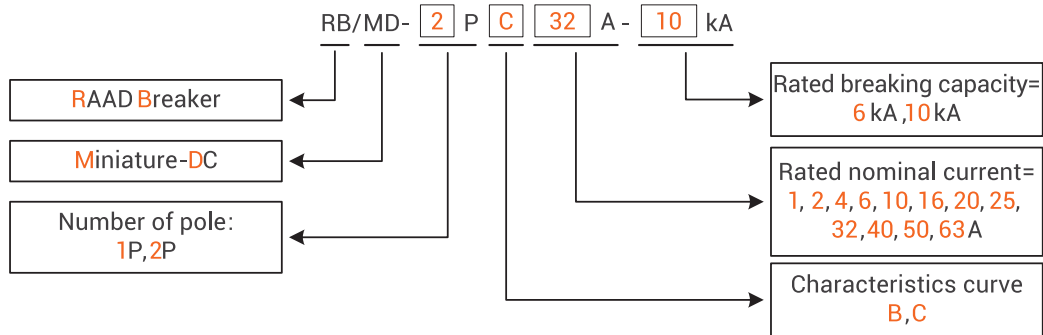

All RAAD MCBs have a unique hologram for the product's authenticity and a text message number informing the customer.



■ RB/MD 1P

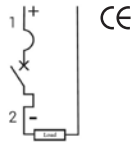

■ RB/MD 2P

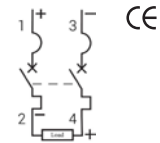

Technical data	RB/MD 1P	RB/MD 2P
Pole	1P	2P
Qty.	12	6
Rated voltage Ue (V DC)	250	500
Rated current Ie (A)	1, 2, 4, 6, 10, 16, 20, 25, 32, 40, 50, 63	
<b>IEC 60947-2 rated data</b>		
Insulation voltage Ui (V)	500	
Rated breaking capacity (kA)	6, 10	
Energy limiting class	3	
Rated impulse withstand Uimp (kV)	4	
AC dielectric test voltage for 1 minute (kV)	3	
Thermo-magnetic release characteristic	B (4×Ie - 7×Ie) C (7×Ie - 12×Ie)	
Reference temperature for setting thermal element (°C)	30	
Ambient temperature (°C) (daily averages ≤ 35 °C)	-5 ~ +40	
Storage temperature (°C)	-25 ~ +70	
<b>Mechanical Features</b>		
Electrical life (Cycles)	4000	
Mechanical life (Cycles)	10000	
Protection degree	IP20	
<b>Installation</b>		
Terminal connection type	Cable, Pin- type busbar, U- type busbar	
Connection capacity for cable/busbar (mm <sup>2</sup> )	0.75 - 25	
Connection capacity for cable/busbar (AWG)	18 - 3	
Striping length (mm)	12	
Tightening torque (N.m)	2.5	
Mounting	DIN 35 (according IEC 60715)	
Connection	From top and bottom	

Accessories	Type	Ordering No.	Qty.
Auxiliary contact	RB/M-CB	6124001101	12
Alarm contact	RB/M-FB	6124101101	12

**Overall and Installation Dimension (mm) :**

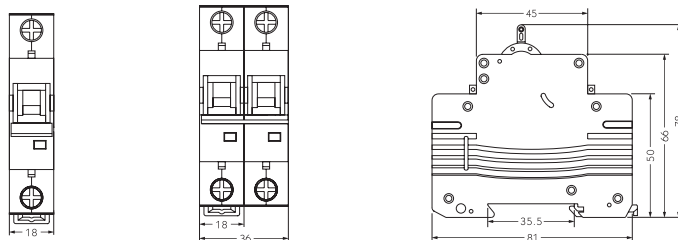

# Auxiliary contact

## RB/M-CB, RB/M-FB

Auxiliary Contacts are used in command circuits, and their task is to add some normally open (NO) and normally close (NC) contacts on circuits. Auxiliary contacts are installed besides MCB or RCBO. these contacts do not protect solitarily; when the MCB or RCBO trips due to a fault, the auxiliary contacts will trips as well.

RAAD Auxiliary contacts are manufactured in two types (FB & CB). The CB type has 1NO+1NC, and the FB type has 2CO (2NO+2NC). In addition, the FB type has an indicator that turns blue when a fault occurs. It is possible to fully identify whether the auxiliary contact was cut off manually or disconnected due to a fault on the MCB or RCBO .

The electrical and mechanical life of RAAD Auxiliary contacts are 6050 and 10,000 cycles, respectively. Production of the contacts are in full compliance with the international standard IEC 60947-5-1.

In the following, it shows the function of the FB auxiliary contact when it is installed next to a MCB in different situations

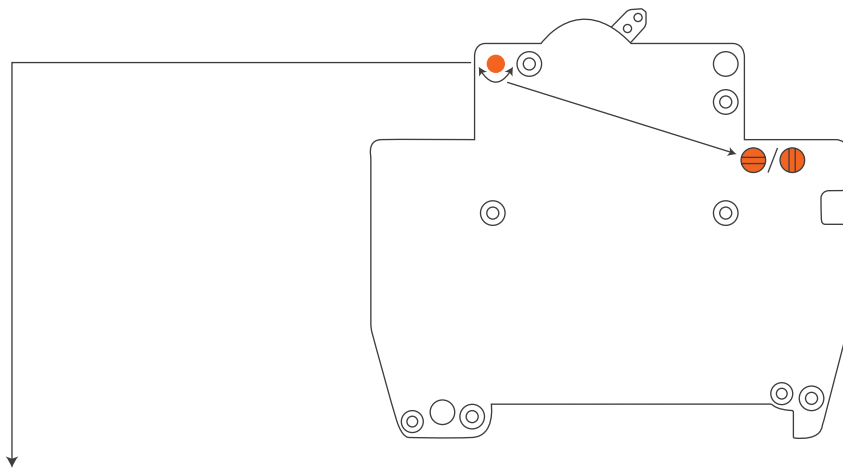

The state of the FB's rotary switch	Situations	MCB lever status	MCB indicator	FB aux indicator	Electrically connected FB's terminals	
	Connection current path of MCB	On	Red	White	11-14	21-24
	Manual MCB disconnection of current path	Off	Green	White	11-12	21-24
	Disconnection of the MCB current path due to the current fault event	Off	Green	Blue	11-12	21-22
	Connection current path of MCB	On	Red	White	11-14	21-24
	Disconnection current path of MCB	Off	Green	Blue	11-12	21-22



■ RB/M-CB

CE

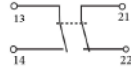

■ RB/M-FB

CE

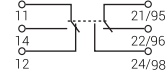

Description	Type	Ordering No.	Qty.
Auxiliary contact	RB/M-CB	6124001101	12
Alarm contact	RB/M-FB	6124101101	12

Utilization category	AC13		AC15		DC12
	AC-230	AC-400	AC-230	AC-400	DC 110
Rated voltage Ue (V)					
Rated current Ie (A)	3	2	2	1	0.5
<b>IEC 60947-5-1 rated data</b>					
Insulation voltage Ui (V)	400				
Rated frequency for Vac (Hz)	50/60				
Rated short circuit making capacity	20Ie, t=0.1s				
Rated impulse withstand Uimp (kV)	2.5				
AC dielectric test voltage for 1 minute (kV)	2				
Ambient temperature (°C) (daily averages ≤ 35 °C)	-5 ~ +40				
Storage temperature (°C)	-25 ~ +70				
<b>Mechanical Features</b>					
Electrical life (Cycles)	6050				
Mechanical life (Cycles)	10000				
Protection degree	IP20				
<b>Installation</b>					
Terminal connection type	Cable				
Connection capacity for cable/busbar (mm <sup>2</sup> )	0.75 - 2.5				
Connection capacity for cable/busbar (AWG)	18 - 13				
Striping length (mm)	6.5				
Tightening torque (N.m)	0.8				

Overall and Installation Dimension (mm) :

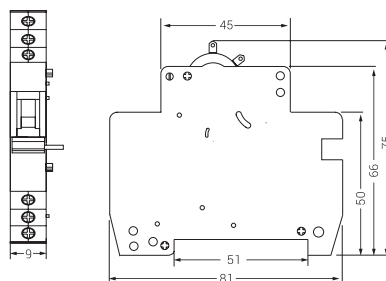

# Residual Current Circuit Breaker (RCCB)

## RB/RC

RCCBs are designed to protect against leakage current, and always note that these products cannot protect against short circuit faults and overload faults.

RAAD Company RCCBs are produced in two rated residual currents (30, 300 mA). The RCCB with 30 mA residual current (household type) is suitable for protection against electric shock. The 300 mA residual current RCCB (industrial type) is for fire protection and protection against leakage current as well. Note that the 300 mA type is not ideal for protection against human shock.

RAAD RCCBs are made of electromagnetic type in AC class. This class breaks the main current flow by less than 100 milliseconds when the detected residual current is between half to one times of the rated residual current.

RCCBs in RAAD are produced in two models, 2P (1P+N) and 4P (3P+N), with the rated current range between 6A and 63A. These specific types endure short-circuit currents up to 6 KA.

The electrical and mechanical life of RAAD RCCBs are 2,000 and 4,000 cycles, respectively.

Two busbars are allocated on the top and bottom sides of the product.

Our RCCBs fully comply with the international standard IEC 61008-1, and have a unique hologram for the product's authenticity and a text message number informing the customer.



RAAD RCCB product selection guide is shown below:

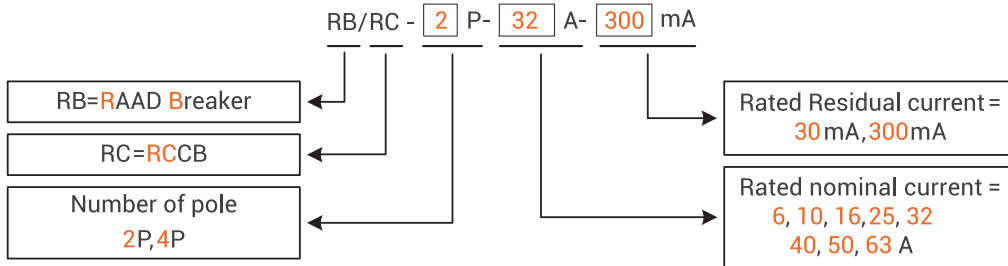



■ RB/RC-2P

CE

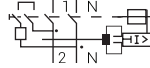

■ RB/RC-4P

CE

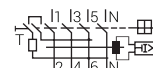

Technical data	RB/RC-2P	RB/RC-4P
Pole	2P (1P+N)	4P (3P+N)
Rated voltage Ue (V)	230	400
Rated current Ie (A)	16, 20, 25, 32, 40, 50, 63	
<b>IEC 61008-1 rated data</b>		
Type	AC	
Insulation voltage Ui (V)	500	
Rated frequency (Hz)	50/60	
Rated residual operation current I <sub>nc</sub> (mA)	30, 300	
Rated residual making and breaking capacity IΔm (A)	500 (Ie=16, 20, 25, 32, 40, 50A) 630 (Ie=63A)	
Short circuit current IΔc (kA)	6	
Short circuit protection device	Fuse 63A 	
Break time under rated residual operation current (s)	≤ 0.1	
Rated impulse withstand Uimp (kV)	4	
AC dielectric test voltage for 1 minute (kV)	2.5	
Ambient temperature (°C) (daily average ≤ 35 °C)	-25 ~ +40	
Storage temperature (°C)	-25 ~ +70	
Contact position indicator	Yes	
<b>Mechanical Features</b>		
Electrical life (Cycles)	2000	
Mechanical life (Cycles)	4000	
Protection degree	IP20	
<b>Installation</b>		
Terminal connection type	Cable, Pin- type busbar, U- type busbar	
Connection capacity for cable/busbar (mm <sup>2</sup> )	0.75 - 25	
Connection capacity for cable/busbar (AWG)	18 - 3	
Striping length (mm)	12	
Tightening torque (N.m)	2.5	
Mounting connection	DIN 35 (according IEC 60715) Power supply in both direction	

**Overall and Installation Dimension (mm) :**

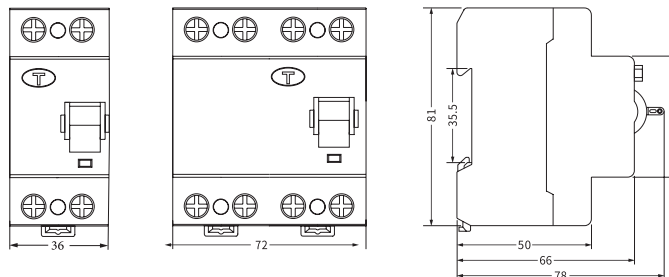

# Residual Current circuit Breaker with Overcurrent

## RB/RO

Residual Current Circuit Breaker with Overcurrent (RCBO) protects circuits against short circuit faults, overload faults, and leakage currents. This product is a combination of a MCB and a RCCB.

RAAD Company RCBOs is in one type, 2P (1P+N). Their nominal current ranges varies from 6A to 63A, and their characteristic curve is C. the rated breaking capacity of RAAD RCBO is 6KA.

RAAD RCBOs are made of electronic type in AC class with rated residual current of 30 mA.

These RCBOs cut off the main current flow by less than 100 milliseconds when the detected residual current is between half to one times of the rated residual current.

The electrical and mechanical life of RAAD RCBOs are 4,000 and 10,000 cycles, respectively.

RAADs RCBOs also have two busbars at the top and bottom of the product. These products can install auxiliary contacts for better use in circuits.

RAAD RCBOs are made in full compliance with the international standard IEC 61009-1. All RCBOs have a unique hologram for the product's authenticity and a text message number informing the customer



RAAD RCBO product selection guide is shown below:

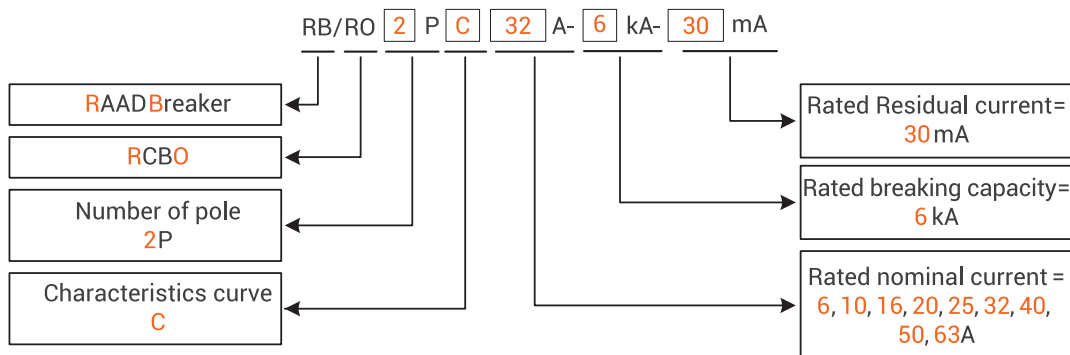



## RB/RO-1P+N

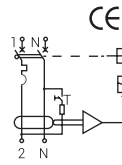

Technical data		RB/RO-1P+N		
Pole		1P+N		
Rated voltage Ue (V)		230V		
Rated current Ie (A)		6, 10, 16, 20, 25, 32, 40, 50, 63		
IEC 61009-1 rated data				
Insulation voltage Ui (V)		500		
Rated frequency (Hz)		50/60		
Rated breaking capacity (kA)		6		
Energy limiting class		3		
Rated impulse withstand Uimp (kV)		4		
Rated residual current IΔn (mA)		30		
Break time under rated residual operation current (s)		≤ 0.1		
AC dielectric test voltage for 1 minute (kV)		2		
Thermo-magnetic characteristic		C (5×In - 10×In)		
Reference temperature for setting thermal element (°C)		30		
Ambient temperature (°C) (daily average ≤ 35 °C)		-25 ~ +55		
Storage temperature (°C)		-25 ~ +70		
Mechanical Features				
Electrical life (Cycles)		4000		
Mechanical life (Cycles)		10000		
Protection degree		IP20		
Installation				
Terminal connection type		Cable, Pin- type busbar, U- type busbar		
Connection capacity for cable/busbar (mm <sup>2</sup> )		0.75 - 25		
Connection capacity for cable/busbar (AWG)		18 - 3		
Striping length (mm)		12		
Tightening torque (N.m)		2.5		
Mounting connection		DIN 35 (according IEC 60715) Power supply from top		
Accessories		Type	Ordering No.	Qty.
Auxiliary contact		RB/M-CB	6124001101	12
Alarm contact		RB/M-FB	6124101101	12

### Overall and Installation Dimension (mm) :

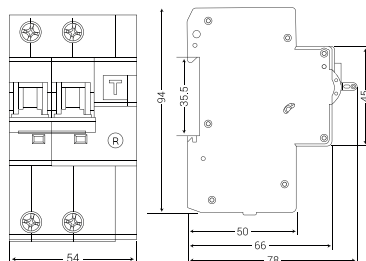



**RAAD**  <sup>®</sup> Electrical Connection for  
Technological Components  
*Confidence in Connection*

# Mounting Rails And Accessories

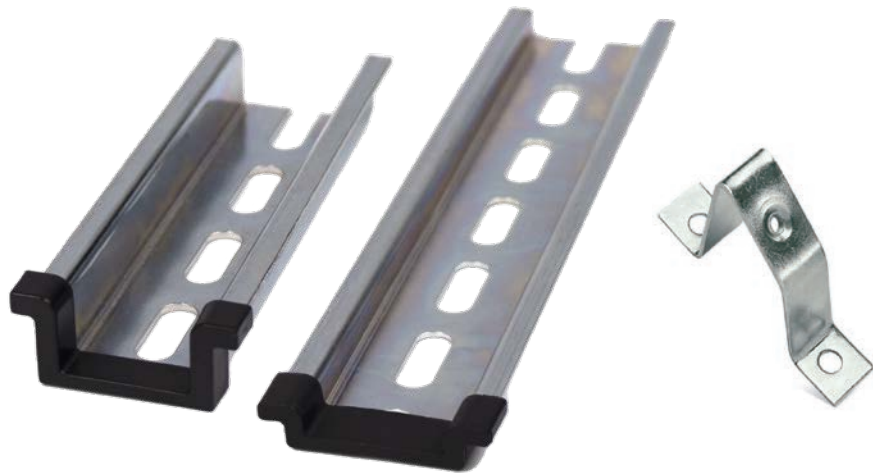

IEC 60715 mounting rails form the basis for mounting modular terminal blocks, rail mountable electro technical, and electric components. Active and passive components are installed on mounting rails. In control cabinet design, the TH 35-15 and TH 35-7.5 rails stand out with their high degree of dimensional accuracy.

All steel versions are electroplated and additionally coated with a white chromate comply with the IEC 60715, EN50022, EN50035 standards. RAAD supplies components which are totally co-ordinated in their functionality.

The mounting rails can also be used as a protective busbar. RAAD protective conductor terminals meet the requirements specified in IEC 60947-7-2.

The rails are both produced in slotted and non-slotted form for easier application by the users.

# Mounting Rail

## TH 35-7.5, 15 /S



The TH35-7.5/s and TH-35-15/s rails are slotted products that are mainly used in electrical cabinets. The operator can use screws to fix the rail on the electrical cabinet. These products are made from cold roll steels and have an cold galvanized coating and a white chromate layer.

Description	TH 35-7.5/S 1m	TH 35-7.5/S 2m	TH 35-15/S 1m	TH 35-15/S 2m
Ordering No.	6090101003	6090101002	6090102003	6090102003
Qty. in package	20	10	20	10
Slotted	Slotted			
<b>Material specifications</b>				
Color	Silver			
Material	Steel			
Coating	Cold galvanized and White chromate			
<b>Standards and regulations</b>				
Connection in according. with standard	IEC 60715, EN50022, EN50035			
Tests	IEC 60715			
<b>Dimensional drawing</b>				
Width (mm)	35			
Hole width (mm)	6.3			
Height (mm)	7.5		15	
Hole Length (mm)	18			
Length (m)	1	2	1	2
Slot pattern distance (mm)	25			
Thickness (mm)	1		1.5	

Overall and Installation Dimension (mm) :

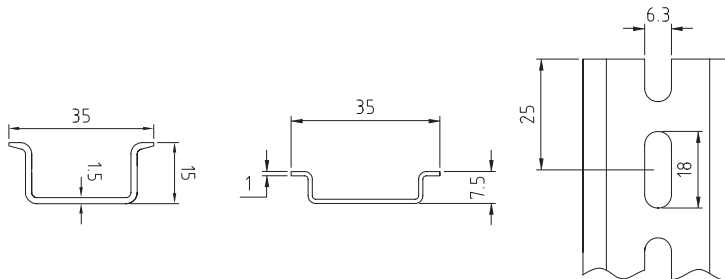

## TH 35-7.5, 15 HG

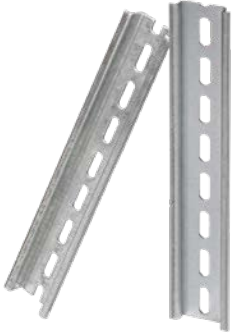

The TH35-7.5 HG and TH35-15 HG rails are slotted products that are mainly used in electrical cabinets. The operator can use screws to fix the rail on the electrical cabinet. These products are made from cold roll steels and have an hot galvanized coating and a white chromate layer.

Description	TH 35-7.5 HG 1m	TH 35-7.5 HG 2m	TH 35-15 HG 1m	TH 35-15 HG 2m
Ordering No.	6090101007	6090101008	6090102007	6090102008
Qty. in package	20	10	20	10
Slotted	Slotted			
<b>Material specifications</b>				
Color	Silver			
Material	Steel			
Coating	Hot galvanized and White chromate			
<b>Standards and regulations</b>				
Connection in according. with standard	IEC 60715, EN50022, EN50035			
Tests	IEC 60715			
<b>Dimensional drawing</b>				
Width (mm)	35			
Hole width (mm)	6.3			
Height (mm)	7.5		15	
Hole Length (mm)	18			
Length (m)	1	2	1	2
Slot pattern distance (mm)	25			
Thickness (mm)	1		1.5	

Overall and Installation Dimension (mm) :

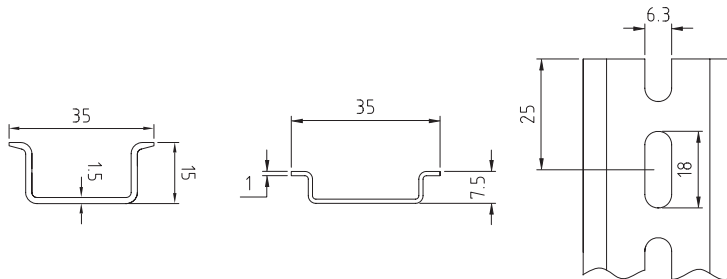

# Mounting Rail Support

## ARS/M6

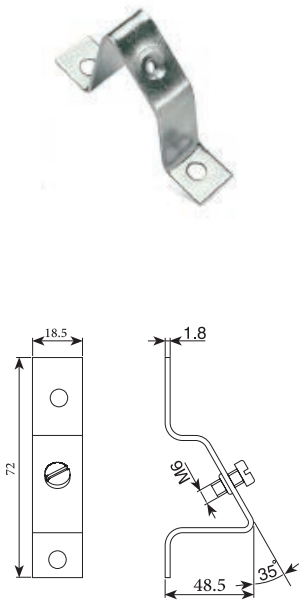

Angled Rail supports (ARS) hold sloped attachment of mounting rails at an angle of 35°. M6 screws are used in this product.

Description	ARS/M6
Type	Angled Rail Support allow for sloped attachment of mounting rail
Ordering No.	6090202001
Qty. in package	10
<b>Material specifications</b>	
Color	Silver
Material	Steel
Coating	Galvanized and White chromate
<b>Dimensional drawing</b>	
Width (mm)	18.5
Height (mm)	48.5
Length (mm)	72
Angled (°)	35
Thickness (mm)	1.8

## Din Rail End Caps (EC-TH35)

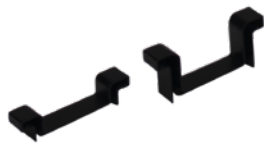

Din Rail End Caps have been designed as a protection of hand hurt against the sharp edges for the technicians and as a close off for the rail products. This product have been made of PA with V2 Flammability rating according to UL 94 and can be used for both TH35-7.5 and TH35-15 Din Rails.

Type	Ordering No.	Material	Qty.
EC-TH35-7.5	6090203001	PA	100
EC-TH35-15	6090203002	PA	100

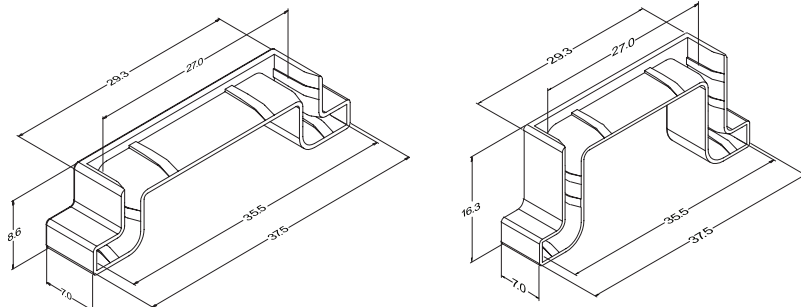

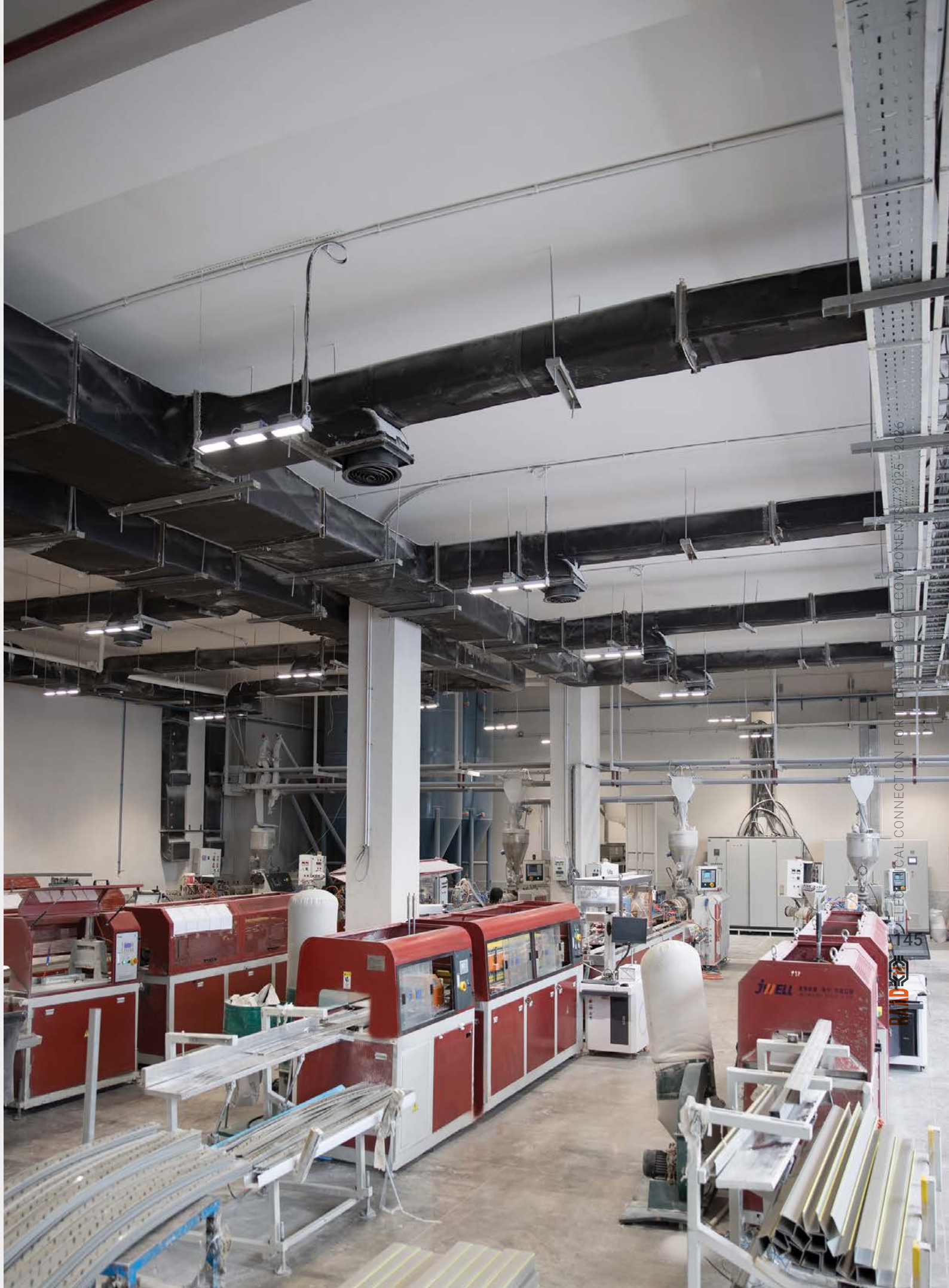



**RAAD**  <sup>®</sup> Electrical Connection for  
Technological Components  
*Confidence in Connection*

# Wiring Duct Systems



As part of the business development efforts, RAAD Manufacturing Co. is now in a position to offer high-quality "WIRING DUCTS" to customers.

These series of wiring ducts, feature an excellent assembly and are ideal for any type of power and control panels preferably for control panels where performance remains unaltered over time even under the heaviest operating conditions.

The reliability and durability of these products are guaranteed by a very severe selection of raw materials employed for their production and rigorous process controls.

Correct installation by qualified staff, proper use, and periodical maintenance contribute to the safety and safeguarding of people and property.

### Construction Specifications



- Slotted wiring duct for installation in cabinets based on standards EN 50085-1+A1 and EN-50085-2-3 (IEC 61084-1+A1).
- The base perforation of the wiring duct allows mounting on the panel.
- Duct material as Rigid PVC, self-extinguishing (non-flame propagating) and resistant to abnormal heat and fire up to 850°C (glow-wire test) in conforming with IEC/EN 60695-2-1 standards.
- Product without Lead (Pb) in accordance with RoHS requirements.
- Technical characteristics of PVC duct as shown in Table 5.
- Complementary construction details as illustrated in Figure 1 to 4.
- Duct dimensional details, as shown in Figures 6.
- Nominal sizes and dimensions as shown in Table 1.
- The thickness of wall, bottom and cover as shown in Table 3.
- Standard length as 2 meters.

### Operating Instruction

- The maximum application (operating) temperature is +60°C in accordance with IEC/EN standards.
- The minimum storage/ transport temperature is -45°C.
- The minimum installation/ application temperature is -25°C.
- The number of conductors must not exceed the recommended values, considering 60% stuffing coefficient (Table 2).
- Suitable for small sized wires employed in electric and electronic control panels.
- The deformation of horizontal duct walls under recommended conductor loading has been considered.
- The acceptability of deformation under more rigorous conditions such as load bearing cover or required mechanical spacing must be evaluated in the end-use investigation.
- High quality products conforming to international standards.
- Designed to meet the needs of panel builders regarding to advanced and time-saving panel assembling.
- Complying with international certificates KEMA, CE

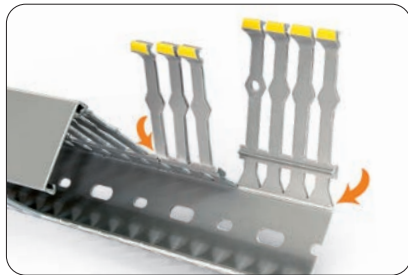

■ **Figure 1**

- Two predetermined break lines for breaking off and removal of sidewall finger segments, sidewall finger, and base segments.



■ **Figure 2**

- The possibility of making different distinct levels, by using special pins inside the holes contrived in the duct fingers.  
It is mentionable that ducts with the height up to 40 (mm), have only one hole in the middle, while for duct height including 60 (mm) and more, two holes provide the above - mentioned possibility.

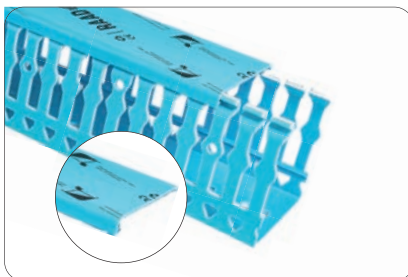

■ **Figure 3**

- Provided with a soft yellow PVC strip (white PVC strip in Blue wire ducts) for handling purposes to avoid hand-accidents during the cabling and making the cover very steady.
- Burr-free edges.



■ **Figure 4**

- These products are designed to provide maximum grip with the minimum involved surface.



■ **Figure 5**

- This label is designed to protect wire ducts' cover from scratches during the product transportation and electrical panel internal parts' installation. It is made of highly durable plastic material.  
It should be mentioned that the customer should remove the tape after the final installation of the cover.

**Table 1- Nominal Sizes**

Nominal size (mm)		color	Ordering No.	Ordering No.	Total Length in Carton (m)	Qty.
Width	Height					
25	40	■ ■	6110105008	6110105108	60	30
	60		6110105012	6110105112	40	20
	80		6110105016	6110105116	20	10
	Cover		6115050005	6115050105	40	20
40	40	■ ■	6110108008	6110108208	40	20
	60		6110108012	6110108212	36	18
	80		6110108016	6110108216	28	14
	Cover		6115050008	6115050108	40	20
60	40	■ ■	6110112008	6110112108	32	16
	60*		6110112012	6110112112	24	12
	80		6110112016	6110112116	16	8
	Cover		6115050012	6115050112	40	20
80	60	■ ■	6110116012	6110116112	20	10
	80		6110116016	6110116116	16	8
	100		6110116020	6110116120	8	4
	Cover		6115050016	6115050116	20	10
100	60	■ ■	6110120012	6110120112	12	6
	80		6110120016	6110120116	8	4
	100		6110120020	6110120120	8	4
	Cover		6115050020	6115050120	20	10

\* This size granted  standard.

- Each standard length is 2 meters.
- For dimensional details see Figure 6.
- Standard unit as duct complete with cover.

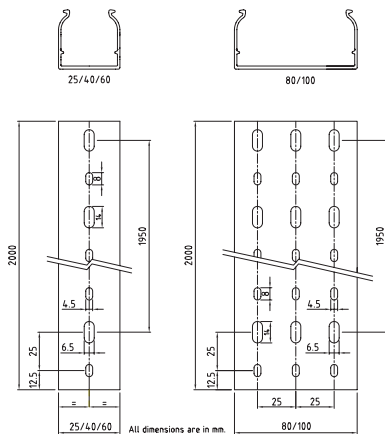

**Figure 6**

Duct Base Dimensional Details

## Table 2

Recommended maximum number of wires to be used per wiring duct is 60% duct total capacity (Wire fill capacity)

Nominal size (mm)	Nominal Cross-Section of Conductors		
	1 (mm <sup>2</sup> ) (O.D=2.717 mm)	1.5 (mm <sup>2</sup> ) (O.D=3.168 mm)	2.5 (mm <sup>2</sup> ) (O.D=3.768 mm)
25x40	81	60	42
25x60	122	90	63
25x80	163	120	84
40x40	130	96	67
40x60	195	144	101
40x80	260	192	134
60x40	195	144	101
60x60*	293	216	151
60x80	390	288	201
80x60	390	288	201
80x80	521	384	269
80x100	651	480	336
100x60	488	360	252
100x80	651	480	336
100x100	813	600	420

\* O.D =Outer Diameter

\* The number of conductors in table 2 is calculated by:  $60\% \times [(W \times H) / (O.D)^2]$

**Table 3** - Standard cross-sections of round copper conductors

For comparison of standard cross-sections between AWG and metric sizes, refer to Table 3 (see IEC 60947-7-1, Table 1)

Metric size ISO (mm <sup>2</sup> )	Comparison between AWG and metric sizes	
	Size (AWG)	Equivalent metric area (mm <sup>2</sup> )
0.2	24	0.205
0.34	22	0.324
0.5	20	0.519
0.75	18	0.82
1	-	-
1.5	16	1.3
2.5	14	2.1
4	12	3.3
6	10	5.3

**Table 4** - Wall, Bottom, Cover Thickness and Dimension

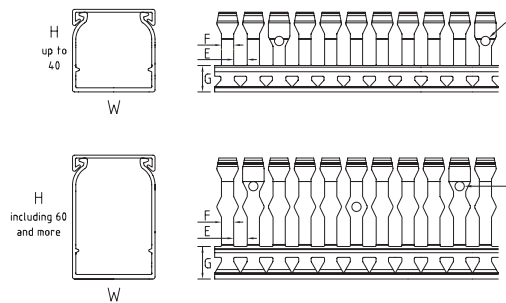

The declared dimensions in table 4 is shown in figure 7.

Duct Nominal Size (WxH) mm	Dimensions (mm)						Thickness (mm)		
	W	H	E	F	G	φ	Walls	Bottom	Cover
25x40	25	40	6.6	5.9	12.8	4.5	1.6	2.0	1.35
25x60	25	60	6.6	5.9	15.8	4.5	1.6	2.0	1.35
25x80	25	80	6.6	5.9	19.8	4.5	1.6	2.0	1.35
40x40	40	40	6.6	5.9	12.8	4.5	1.6	2.0	1.35
40x60	40	60	6.6	5.9	15.8	4.5	1.6	2.0	1.35
40x80	40	80	6.6	5.9	19.8	4.5	1.9	2.0	1.35
60x40	60	40	6.6	5.9	12.8	4.5	1.6	2.0	1.35
60x60*	60	60	6.6	5.9	15.8	4.5	1.9	2.0	1.35
60x80	60	80	6.6	5.9	19.8	4.5	1.9	2.0	1.35
80x60	80	60	6.6	5.9	15.8	4.5	1.9	2.0	1.5
80x80	80	80	6.6	5.9	19.8	4.5	1.9	2.0	1.5
80x100	80	100	6.6	5.9	19.8	4.5	1.9	2.0	1.5
100x60	100	60	6.6	5.9	15.8	4.5	1.9	2.0	1.5
100x80	100	80	6.6	5.9	19.8	4.5	2	2.0	1.5
100x100	100	100	6.6	5.9	19.8	4.5	1.9	2.0	1.5

## ■ Non-slotted Wiring Duct

Using RAAD Non-slotted wiring duct (HWD type) makes your room look more appealing by hiding and safely storing the wires that go across walls, and ceilings. HWDs are widely used in buildings, offices and residential properties, just to name a few. Using the HWDs will provide your wires with an appropriate casing, helping you to place your cables into pre-determined paths. This product comes with a cover to simplify the process of purchasing. The use of heat-resistant PVC avoids any damage caused by the heat-emitting equipments.



Nominal Size (WxH) mm	Ordering No.	Qty. in Package	Total Length in Package (m)
20 x 12	6110204003	65	130
20 x 20	6110204004	42	84
25 x 20	6110205004	36	72
30 x 30	6110206006	20	40
40 x 40	6110208008	20	40
60 x 40	6110212008	16	32
60 x 60	6110212012	12	24
100 x 60	6110220020	6	12

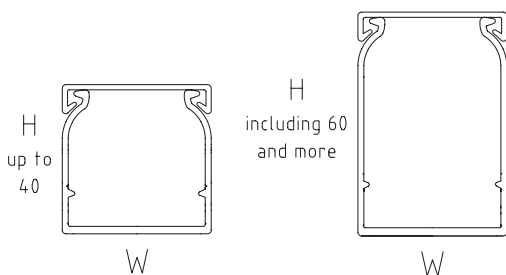

■ Figure 1

Duct Base Dimensional Details

## Self-Adhesive Non-Slotted Wiring Duct

Using RAAD Self-adhesive non-slotted wiring duct (HWDS type) makes your room look more appealing by hiding and safely storing the wires that go across walls, and ceilings.

HWDS duct is made of HWD duct with a self-adhesive sticker, which is provided for faster and easier installation.

Using the HWDSs will provide your wires with an appropriate casing, helping you to place your cables into pre-determined paths. This product comes with a cover to simplify the process of purchasing. The use of heat-resistant PVC avoids any damage caused by the heat-emitting equipments.



Nominal Size (WxH) mm	Ordering No.	Qty. in Package	Total Length in Package (m)
20 x 12	6110204001	65	130
20 x 20	6110204002	42	84
25 x 20	6110205001	36	72
30 x 30	6110206001	20	40

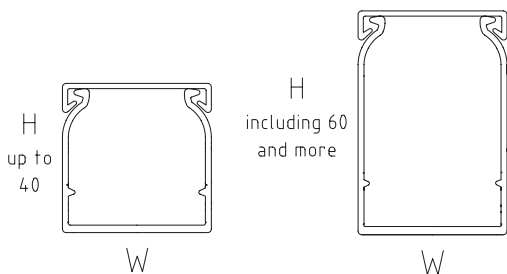
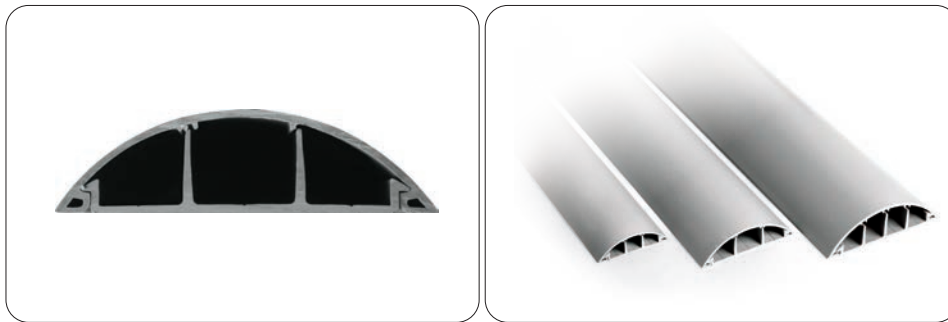

Figure 1

Duct Base Dimensional Details

## ■ Onfloor Wiring Duct (OWD)

- Insulating, shock-proof, self-extinguishing material
- Standard 2-meter long base complete with cover
- Complying with the EN 50085-2-2 European Standard
- Residential and commercial application
- Special design giving high resistance to pressure
- Degree of protection IP40
- Various compartments suitable for housing electric, telephone, and data transmission cables separately
- Providing optimum reliability and safety through compliance with relevant standards
- Providing high cable retention



Nominal Size (WxH) mm	Ordering No.	Qty. in carton	Total Length in carton
50 x 13	6110310010	30	60
70 x 18	6110310014	14	28
90 x 24	6110310018	8	16

RAAD Onfloor Wiring Ducts can be ordered in 3 sizes as follows.

### OWD 50 x 13

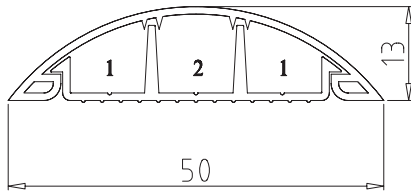

Duct Size		50 x 13	
Technical Information		Compartment	
		1	2
Useful cross section (mm <sup>2</sup> )		76	103
Cable Ø Max (mm)		9.1	11
Usable cross section area (mm <sup>2</sup> )	1.5	6	8
	2.5	5	6
	4	3	4
	6	2	3

### OWD 70 x 18

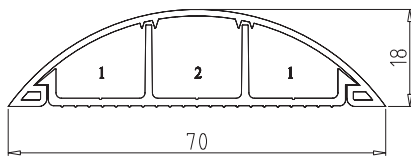

Duct Size		70 x 18	
Technical Information		Compartment	
		1	2
Useful cross section (mm <sup>2</sup> )		174	244
Cable Ø Max (mm)		11	16.2
Usable cross section area (mm <sup>2</sup> )	1.5	11	15
	2.5	9	13
	4	6	10
	6	4	6

### OWD 90 x 24

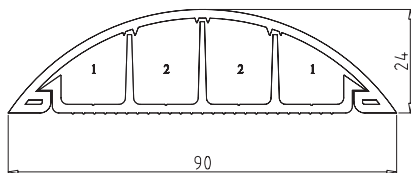

Duct Size		90 x 24	
Technical Information		Compartment	
		1	2
Useful cross section (mm <sup>2</sup> )		195.5	298
Cable Ø Max (mm)		12.9	16.2
Usable cross section area (mm <sup>2</sup> )	1.5	13	19
	2.5	10	16
	4	7	11
	6	5	7



YZC-516C  
200Kg  
G  
GUANG CE

**RAAD**  <sup>®</sup> Electrical Connection for  
Technological Components

*Confidence in Connection*

# Nylon Cable Tie



RAAD Cable Ties features are as following:

- Available in seven sizes
- High tensile strength with very low insertion force
- Made of high quality engineering plastic PA6.6
- Ergonomic bend tail offers quick and simple installation
- Easy application either manually or with an application tool

IEC 62275		Cable tie			
Material		PA6.6			
Flammability		UL 94 V2			
Operating Temperature (°C)		-40 ~ +80			
Name	Ordering Number	Color	Qty.	ØBundle (mm)	
				min	max
RC 100*2.5	6100100010	Natural	100	2.0	21.0
RC 150*2.5	6100100015		100	2.0	34.0
RC 200*2.5	6100100020		100	2.0	55.0
RC 200*3.6	6100200020		100	2.5	54.0
RC 250*3.6	6100200025		100	2.5	70.0
RC 300*3.6	6100200030		100	2.5	82.0
RC 400*4.8	6100300040		100	3.0	110.0

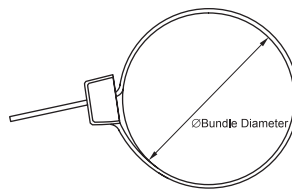

Dimension (mm)			
Name	L	W	T
RC 100*2.5	98.00±2.00	2.50±0.05	1.00±0.05
RC 150*2.5	148.00±2.00	2.50±0.05	1.10±0.05
RC 200*2.5	198.00±2.00	2.50±0.10	1.15±0.10
RC 200*3.6	198.00±2.00	3.60±0.10	1.20±0.10
RC 250*3.6	245.00±5.00	3.60±0.10	1.30±0.10
RC 300*3.6	295.00±5.00	3.60±0.10	1.40±0.05
RC 400*4.8	395.00±5.00	4.75±0.05	1.35±0.10

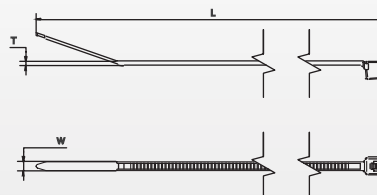



**RAAD**  <sup>®</sup> Electrical Connection for  
Technological Components  
*Confidence in Connection*

# Control Switches



The range of 22mm diameter Control Switches is designed in accordance to IEC 60947-5-1 and IEC 60947-5-5 to provide the following features:

- Easy and rapid installation
- Fixing method unaffected by excessive vibration
- Produced from flame resistant material
- Plastic body construction resistant to corrosion and longer mechanical life
- Independent assembling of NC, NO, and Lamp contacts and freely combined for convenient replacement
- Outstanding appearance and ergonomics
- The BA9S lamp can be requested in each color
- Resistant to unwilling rotation during normal operation, due to anti-rotation washer.

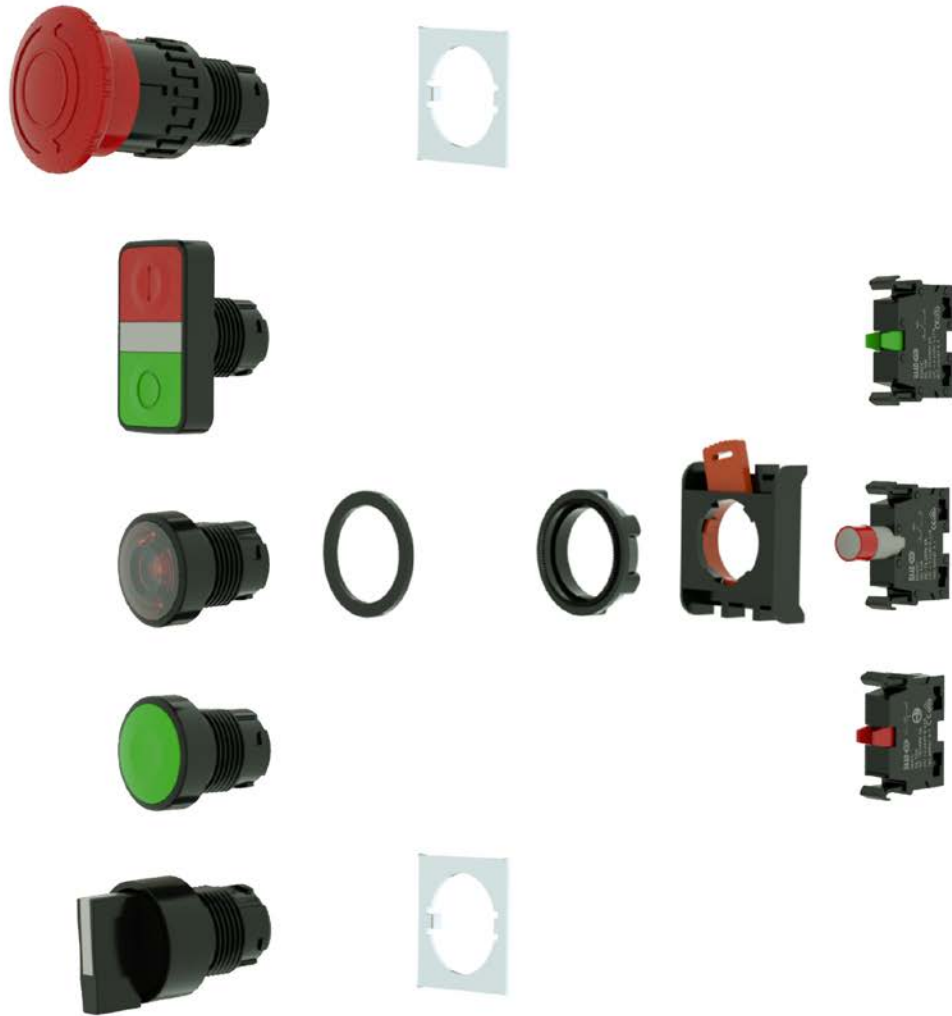

Working and mounting conditions:	
Conforming standard	IEC 60947-5-1
Ambient temperature	-20 ~ +70
Material	PA
Pollution degree	3
Technical Data:	
Rated insulation voltage (V)	400
Rated impulse withstand voltage(kV)	4
Conventional thermal current(A)	10
Utilization Category	AC-15, DC-13
Rated operational voltage(V)*	Rated operational current(A)
380	1.9
240	3
120	6

\* For illuminated push buttons the rated operational voltage of lamps are: 24, 48, 110, 220 V (AC/DC)



IEC 60947-5-1	FB-O			FB-C				
Impulse Voltage (kV)	4			4				
Rated Insulation Voltage (V)	400			400				
Current (A)	3			3				
Pollution Degree/Voltage Category/Material Group	3/III/I			3/III/I				
Utilization Category	AC-15, DC-13			AC-15, DC-13				
Ambient Temperature (°C)	-20 ~ +70			-20 ~ +70				
<b>Contact</b>								
Contact type	NO	NC	Lamp	NO	NC	Lamp		
Diagram								
Number of contacts	1	-	-	-	1	-		
<b>Description</b>	<b>Voltage (v)</b>	<b>Color</b>	<b>Ordering No.</b>	<b>Qty</b>	<b>Voltage (v)</b>	<b>Color</b>	<b>Ordering No.</b>	<b>Qty</b>
Pushbutton, Spring-return	Up to 380		6070302001	15	Up to 380		6070301001	15
			6070302006					
			6070302005					
			6070302004					
			6070302009					
<b>Connection Capacity</b>								
Rigid Solid (mm <sup>2</sup> )				0.5-4				
Stripping Length (mm)				9				
Clamping Screw				M3				
Tightening Torque (N.m)				0.5				
<b>Insulation material</b>								
Height from the electrical panel surface (mm)				PA				
				10.0				

**Overall and Installation Dimension (mm) :**

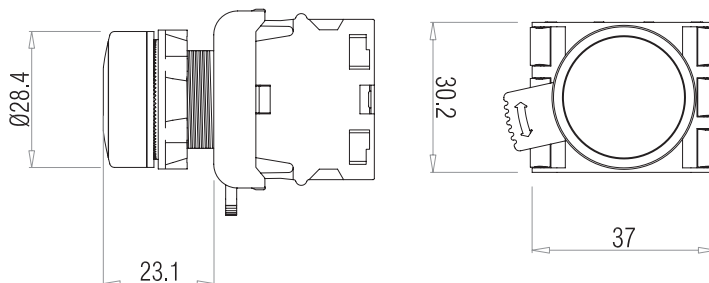



■ FBC-O



■ FBC-C



IEC 60947-5-1	FBC-O			FBC-C				
Impulse Voltage (kV)	4			4				
Rated Insulation Voltage (V)	400			400				
Current (A)	3			3				
Pollution Degree/Voltage Category/Material Group	3/III/I			3/III/I				
Utilization Category	AC-15, DC-13			AC-15, DC-13				
Ambient Temperature (°C)	-5~40			-5~40				
<b>Contact</b>								
Contact type	NO	NC	Lamp	NO	NC	Lamp		
Diagram								
Number of contacts	1	-	-	-	1	-		
<b>Description</b>	<b>Voltage (v)</b>	<b>Color</b>	<b>Ordering No.</b>	<b>Qty</b>	<b>Voltage (v)</b>	<b>Color</b>	<b>Ordering No.</b>	<b>Qty</b>
Pushbutton, Spring-return	Up to 380		6070302101	15	Up to 380		6070301101	15
			6070302106					
			6070302105					
			6070302104					
			6070302102					
<b>Connection Capacity</b>								
Rigid Solid (mm <sup>2</sup> )				0.5-4				
Stripping Length (mm)				9				
Clamping Screw				M3				
Tightening Torque (N.m)				0.5				
<b>head insulation material</b>								
PC/ABS with White chromated coating								
<b>Body insulation material</b>								
PA								
<b>Height from the electrical panel surface (mm)</b>								
10.0								

**Overall and Installation Dimension (mm) :**

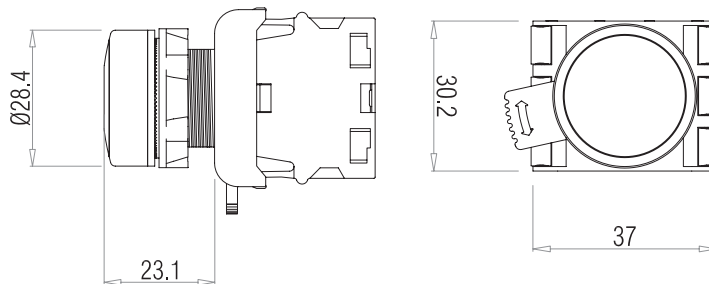



■ FBL-O



■ FBL-C



IEC 60947-5-1		FBL-O				FBL-C			
Impulse Voltage (kV)		4				4			
Rated Insulation Voltage (V)		400				400			
Current (A)		3				3			
Pollution Degree/Voltage Category/Material Group		3/III/I				3/III/I			
Utilization Category		AC-15, DC-13				AC-15, DC-13			
Ambient Temperature (°C)		-5~40				-5~40			
Contact									
Contact type		NO	NC	Lamp	NO	NC	Lamp		
Diagram									
Number of contacts		1	-	1	-	1	1		
Description	Voltage (V AC/DC)	Color	Ordering No.	Qty	Voltage (V AC/DC)	Color	Ordering No.	Qty	
Pushbutton, Spring-return, Illuminated with lamp ...	24		6070302008	15	24		6070301006	15	
			6070302027						
			6070302023						
			6070302019						
Pushbutton, Spring-return, Illuminated with lamp ...	48		6070302007	15	48		6070301005	15	
			6070302026						
			6070302022						
			6070302018						
Pushbutton, Spring-return, Illuminated with lamp ...	110		6070302003	15	110		6070301004	15	
			6070302025						
			6070302021						
			6070302017						
Pushbutton, Spring-return, Illuminated with lamp ...	220		6070302002	15	220		6070301003	15	
			6070302024						
			6070302020						
			6070302016						
Connection Capacity									
Rigid Solid (mm <sup>2</sup> )		0.5-4							
Stripping Length (mm)		9							
Clamping Screw		M3							
Tightening Torque (N.m)		0.5							
Insulation material									
Height from the electrical panel surface (mm)		10.0							

**Overall and Installation Dimension (mm) :**

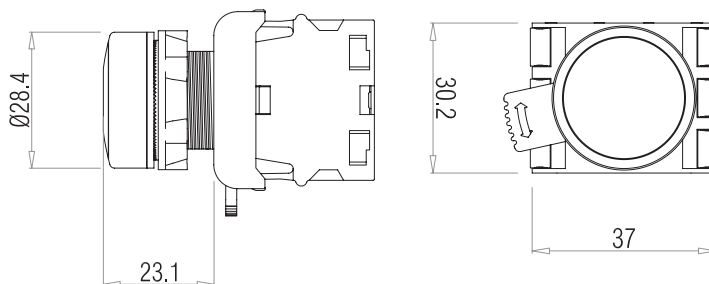



■ FBCL-O



■ FBCL-C



IEC 60947-5-1	FBCL-O			FBCL-C				
Impulse Voltage (kV)	4			4				
Rated Insulation Voltage (V)	400			400				
Current (A)	3			3				
Pollution Degree/Voltage Category/Material Group	3/III/I			3/III/I				
Utilization Category	AC-15, DC-13			AC-15, DC-13				
Ambient Temperature (°C)	-5~40			-5~40				
Contact								
Contact type	NO	NC	Lamp	NO	NC	Lamp		
Diagram								
Number of contacts	1	-	1	-	1	1		
Description	Voltage (V AC/DC)	Color	Ordering No.	Qty	Voltage (V AC/DC)	Color	Ordering No.	Qty
Pushbutton, Spring-return, Illuminated with lamp ...	24		6070302111	15	24		6070301106	15
			6070302127					
			6070302123					
			6070302115					
Pushbutton, Spring-return, Illuminated with lamp ...	48		6070302110	15	48		6070301105	15
			6070302126					
			6070302122					
			6070302114					
Pushbutton, Spring-return, Illuminated with lamp ...	110		6070302109	15	110		6070301104	15
			6070302125					
			6070302121					
			6070302113					
Pushbutton, Spring-return, Illuminated with lamp ...	220		6070302108	15	220		6070301103	15
			6070302124					
			6070302120					
			6070302112					
Connection Capacity								
Rigid Solid (mm <sup>2</sup> )				0.5-4				
Stripping Length (mm)				9				
Clamping Screw				M3				
Tightening Torque (N.m)				0.5				
Head insulation material				PC/ABS with white chromated coating				
Body insulation material				PA				
Height from the electrical panel surface (mm)				10.0				

**Overall and Installation Dimension (mm) :**

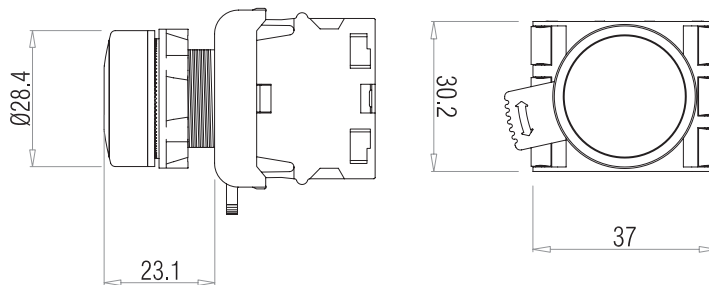



DPB



DPBC



IEC 60947-5-1	DPB			DPBC		
Impulse Voltage (kV)	4			4		
Rated Insulation Voltage (V)	400			400		
Current (A)	3			3		
Pollution Degree/Voltage Category/Material Group	3/III/I			3/III/I		
Utilization Category	AC-15, DC-13			AC-15, DC-13		
Ambient Temperature (°C)	-5~40			-5~40		
<b>Contact</b>						
Contact type	NO	NC	Lamp	NO	NC	Lamp
Diagram						
Number of contacts	1	1	-	1	1	-
<b>Description</b>	<b>Voltage (v)</b>	<b>Ordering No.</b>	<b>Qty</b>	<b>Voltage (v)</b>	<b>Ordering No.</b>	<b>Qty</b>
Double Pushbutton Spring-return	Up to 380	6070303001	10	Up to 380	6070303101	10
<b>Connection Capacity</b>						
Rigid Solid (mm <sup>2</sup> )				0.5-4		
Stripping Length (mm)				9		
Clamping Screw				M3		
Tightening Torque (N.m)				0.5		
<b>Head insulation material</b>	PA			PC/ABS with white chromated coating		
Body insulation material				PA		
Height from the electrical panel surface (mm)				10.50		

Overall and Installation Dimension (mm) :

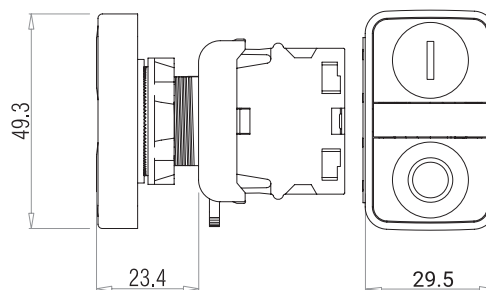



DPBL  
VDE CE



DPBCL  
VDE CE

IEC 60947-5-1	DPBL			DPBCL		
Impulse Voltage (kV)	4			4		
Rated Insulation Voltage (V)	400			400		
Current (A)	3			3		
Pollution Degree/Voltage Category/Material Group	3/III/I			3/III/I		
Utilization Category	AC-15, DC-13			AC-15, DC-13		
Ambient Temperature (°C)	-5~40			-5~40		
<b>Contact</b>						
Contact type	NO	NC	Lamp	NO	NC	Lamp
Diagram						
Number of contacts	1	1	1	1	1	1
<b>Description</b>	<b>Voltage (V AC/DC)</b>	<b>Ordering No.</b>	<b>Qty</b>	<b>Voltage (V AC/DC)</b>	<b>Ordering No.</b>	<b>Qty</b>
Double Pushbutton Spring-return Illuminated with lamp	24	6070303009	10	220	6070303102	10
	48	6070303008	10			
	110	6070303007	10			
	220	6070303002	10			
Double Pushbutton Spring-return Illuminated with RED lamp	220	6070303003	10	220	6070303103	10
<b>Connection Capacity</b>						
Rigid Solid (mm <sup>2</sup> )				0.5-4		
Stripping Length (mm)				9		
Clamping Screw				M3		
Tightening Torque (N.m)				0.5		
<b>Head insulation material</b>	PA			PC/ABS with white chromated coating		
Body insulation material				PA		
Height from the electrical panel surface (mm)				10.50		

**Double Pushbutton With Protection cover:**



Type	Voltage (V AC/DC)	Lamp Color	Ordering No.	Qty.
DPB- C	-		6070303036	10
DPBL- C	220		6070303037	
DPBL- C	220		6070303038	
DPBL- C	110		6070303039	
DPBL- C	48		6070303040	
DPBL- C	24		6070303041	
DPBC- C	-		6070303042	
DPBCL- C	220		6070303043	
DPBCL- C	220		6070303044	



ESTR



IEC 60947-5-1	ESTR		
Impulse Voltage (kV)	4		
Rated Insulation Voltage (V)	400		
Current (A)	3		
Pollution Degree/Voltage Category/Material Group	3/III/I		
Utilization Category	AC-15, DC-13		
Ambient Temperature (°C)	-5~40		
<b>Contact</b>			
Contact type	NO	NC	Lamp
Diagram			
Number of contacts	-	1	-
<b>Description</b>	<b>Voltage (v)</b>	<b>Ordering No.</b>	<b>Qty</b>
Emergency stop button, Turn to release ESTR Spring-return	Up to 380	6070301002	10
<b>Connection Capacity</b>			
Rigid Solid (mm <sup>2</sup> )	0.5-4		
Stripping Length (mm)	9		
Clamping Screw	M3		
Tightening Torque (N.m)	0.5		
<b>Insulation material</b>			
Height from the electrical panel surface (mm)	PA		
	26.50		

**Overall and Installation Dimension (mm) :**

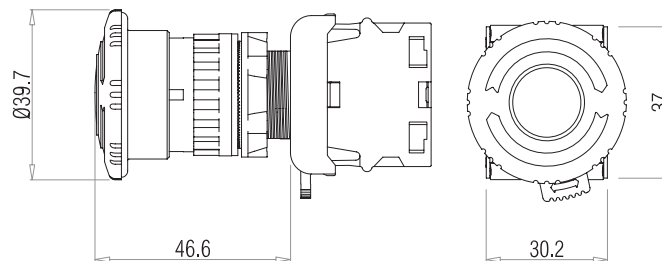









SEI2

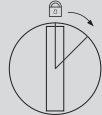
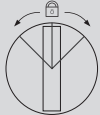

SEI3



IEC 60947-5-1	SEI2			SEI3				
Impulse Voltage (kV)	4			4				
Rated Insulation Voltage (V)	400			400				
Current (A)	3			3				
Pollution Degree/Voltage Category/Material Group	3/III/I			3/III/I				
Utilization Category	AC-15, DC-13			AC-15, DC-13				
Ambient Temperature (°C)	-20 ~ +70			-20 ~ +70				
Type of position	 Two position momentary			 Three position momentary				
<b>Contact</b>								
Contact type	NO	NC	Lamp	NO	NC	Lamp		
Diagram								
Number of contacts	1	-	-	2	-	-		
<b>Description</b>	<b>Voltage (v)</b>	<b>Type</b>	<b>Ordering No.</b>	<b>Qty</b>	<b>Voltage (v)</b>	<b>Type</b>	<b>Ordering No.</b>	<b>Qty</b>
Selector switch, momentary	Up to 380	SEI2	6070303010	12	Up to 380	SEI3	6070303011	12
<b>Connection Capacity</b>								
Rigid Solid (mm <sup>2</sup> )	0.5-4							
Stripping Length (mm)	9							
Clamping Screw	M3							
Tightening Torque (N.m)	0.5							
<b>Insulation material</b>								
Height from the electrical panel surface (mm)	26.50							

Overall and Installation Dimension (mm) :

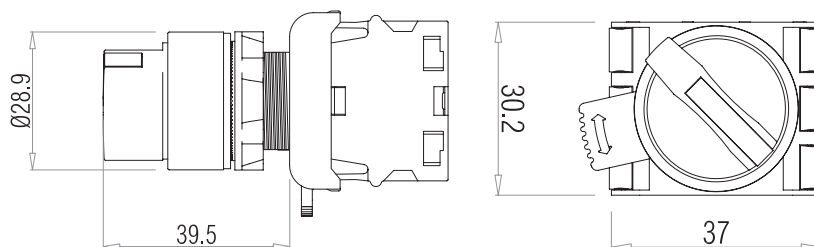



SEIC2



SEIC3



IEC 60947-5-1	SEIC2			SEIC3				
Impulse Voltage (kV)	4			4				
Rated Insulation Voltage (V)	400			400				
Current (A)	3			3				
Pollution Degree/Voltage Category/Material Group	3/III/I			3/III/I				
Utilization Category	AC-15, DC-13			AC-15, DC-13				
Ambient Temperature (°C)	-20 ~ +70			-20 ~ +70				
Type of position	 Two position momentary			 Three position momentary				
<b>Contact</b>								
Contact type	NO	NC	Lamp	NO	NC	Lamp		
Diagram								
Number of contacts	1	-	-	2	-	-		
<b>Description</b>	<b>Voltage (v)</b>	<b>Type</b>	<b>Ordering No.</b>	<b>Qty</b>	<b>Voltage (v)</b>	<b>Type</b>	<b>Ordering No.</b>	<b>Qty</b>
Selector switch, momentary, coated	Up to 380	SEIC2	6070303110	12	Up to 380	SEIC3	6070303111	12
<b>Connection Capacity</b>								
Rigid Solid (mm <sup>2</sup> )				0.5-4				
Stripping Length (mm)				9				
Clamping Screw				M3				
Tightening Torque (N.m)				0.5				
<b>Insulation material</b>								
Height from the electrical panel surface (mm)				26.50				

Overall and Installation Dimension (mm) :

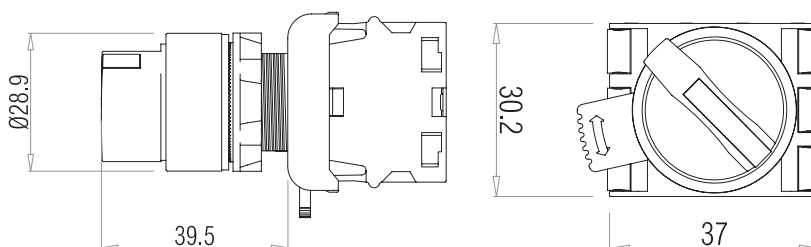











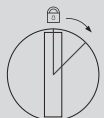
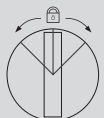







SEI2-L



SEI3-L



IEC 60947-5-1	SEI2-L			SEI3-L				
Impulse Voltage (kV)	4			4				
Rated Insulation Voltage (V)	400			400				
Current (A)	3			3				
Pollution Degree/Voltage Category/Material Group	3/III/I			3/III/I				
Utilization Category	AC-15, DC-13			AC-15, DC-13				
Ambient Temperature (°C)	-20 ~ +70			-20 ~ +70				
Type of position	 Two position momentary			 Three position momentary				
<b>Contact</b>								
Contact type	NO	NC	Lamp	NO	NC	Lamp		
Diagram								
Number of contacts	1	-	1	2	-	1		
<b>Description</b>	<b>Voltage (V AC/DC)</b>	<b>Color</b>	<b>Ordering No.</b>	<b>Qty</b>	<b>Voltage (V AC/DC)</b>	<b>Color</b>	<b>Ordering No.</b>	<b>Qty</b>
Selector switch, momentary with lamp (SEI-L)	24		6070303030	12	24		6070303034	12
			6070303031	12			6070303035	12
	220		6070303012	12		6070303014	12	
			6070303013	12		6070303015	12	
			6070303016	12		6070303017	12	
		<b>Connection Capacity</b>						
Rigid Solid (mm <sup>2</sup> )				0.5-4				
Stripping Length (mm)				9				
Clamping Screw				M3				
Tightening Torque (N.m)				0.5				
<b>Insulation material</b>								
Height from the electrical panel surface (mm)				26.50				



**Overall and Installation Dimension (mm) :**

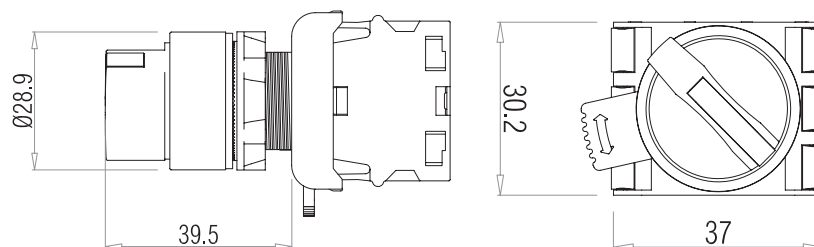











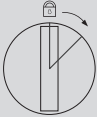
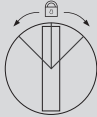



SEIC2-L



SEIC3-L



IEC 60947-5-1	SEIC2-L			SEIC3-L				
Impulse Voltage (kV)	4			4				
Rated Insulation Voltage (V)	400			400				
Current (A)	3			3				
Pollution Degree/Voltage Category/Material Group	3/III/I			3/III/I				
Utilization Category	AC-15, DC-13			AC-15, DC-13				
Ambient Temperature (°C)	-20 ~ +70			-20 ~ +70				
Type of position	 Two position momentary			 Three position momentary				
<b>Contact</b>								
Contact type	NO	NC	Lamp	NO	NC	Lamp		
Diagram								
Number of contacts	1	-	1	2	-	1		
<b>Description</b>	<b>Voltage (V AC/DC)</b>	<b>Color</b>	<b>Ordering No.</b>	<b>Qty</b>	<b>Voltage (V AC/DC)</b>	<b>Color</b>	<b>Ordering No.</b>	<b>Qty</b>
Selector switch, momentary, coated and with lamp (SEIC-L)	220		6070303112	12	220		6070303114	12
			6070303113	12			6070303115	12
			6070303117	12			6070303116	12
<b>Connection Capacity</b>								
Rigid Solid (mm <sup>2</sup> )	0.5-4							
Stripping Length (mm)	9							
Clamping Screw	M3							
Tightening Torque (N.m)	0.5							
<b>Insulation material</b>								
Height from the electrical panel surface (mm)	26.50							

Overall and Installation Dimension (mm) :

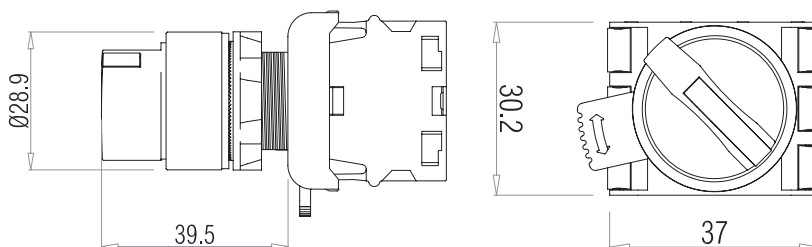









■ SES2

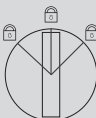

■ SES3



IEC 60947-5-1	SES2			SES3				
Impulse Voltage (kV)	4			4				
Rated Insulation Voltage (V)	400			400				
Current (A)	3			3				
Pollution Degree/Voltage Category/Material Group	3/III/I			3/III/I				
Utilization Category	AC-15, DC-13			AC-15, DC-13				
Ambient Temperature (°C)	-20 ~ +70			-20 ~ +70				
Type of position	 Two position stay-put			 Three position stay-put				
<b>Contact</b>								
Contact type	NO	NC	Lamp	NO	NC	Lamp		
Diagram								
Number of contacts	1	-	-	2	-	-		
<b>Description</b>	<b>Voltage (v)</b>	<b>Type</b>	<b>Ordering No.</b>	<b>Qty</b>	<b>Voltage (v)</b>	<b>Type</b>	<b>Ordering No.</b>	<b>Qty</b>
Selector switch, stay-put (SES)	Up to 380	SES2	6070303020	12	Up to 380	SES3	6070303021	12
<b>Connection Capacity</b>								
Rigid Solid (mm <sup>2</sup> )	0.5-4							
Stripping Length (mm)	9							
Clamping Screw	M3							
Tightening Torque (N.m)	0.5							
<b>Insulation material</b>								
Height from the electrical panel surface (mm)	26.50							

**Overall and Installation Dimension (mm) :**

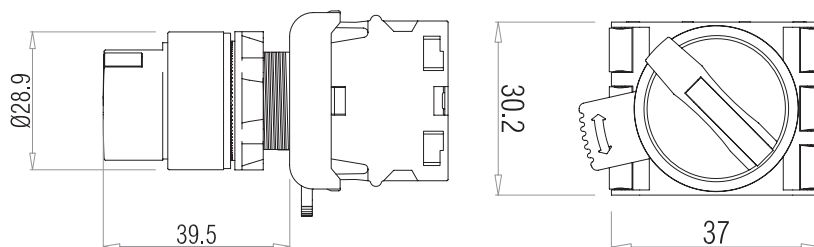











■ SESC2



■ SESC3



IEC 60947-5-1	SESC2			SESC3				
Impulse Voltage (kV)	4			4				
Rated Insulation Voltage (V)	400			400				
Current (A)	3			3				
Pollution Degree/Voltage Category/Material Group	3/III/I			3/III/I				
Utilization Category	AC-15, DC-13			AC-15, DC-13				
Ambient Temperature (°C)	-20 ~ +70			-20 ~ +70				
Type of position	 Two position stay-put			 Three position stay-put				
<b>Contact</b>								
Contact type	NO	NC	Lamp	NO	NC	Lamp		
Diagram								
Number of contacts	1	-	-	2	-	-		
<b>Description</b>	<b>Voltage (v)</b>	<b>Type</b>	<b>Ordering No.</b>	<b>Qty</b>	<b>Voltage (v)</b>	<b>Type</b>	<b>Ordering No.</b>	<b>Qty</b>
Selector switch, stay-put, coated (SESC)	Up to 380	SESC2	6070303120	12	Up to 380	SESC3	6070303121	12
<b>Connection Capacity</b>								
Rigid Solid (mm <sup>2</sup> )	0.5-4							
Stripping Length (mm)	9							
Clamping Screw	M3							
Tightening Torque (N.m)	0.5							
<b>Insulation material</b>								
Height from the electrical panel surface (mm)	PA							
	26.50							

Overall and Installation Dimension (mm) :

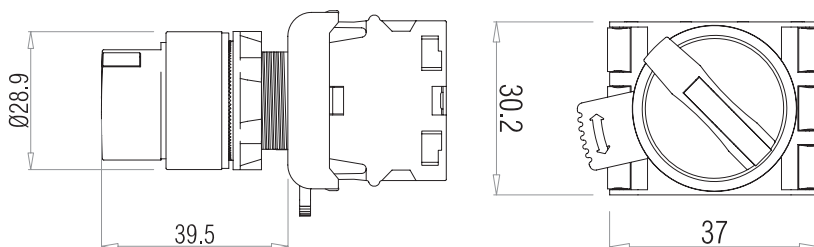



■ SES2-L



■ SES3-L



IEC 60947-5-1	SES2 - L			SES3-L				
Impulse Voltage (kV)	4			4				
Rated Insulation Voltage (V)	400			400				
Current (A)	3			3				
Pollution Degree/Voltage Category/Material Group	3/III/I			3/III/I				
Utilization Category	AC-15, DC-13			AC-15, DC-13				
Ambient Temperature (°C)	-20 ~ +70			-20 ~ +70				
Type of position	 Two position stay-put			 Three position stay-put				
<b>Contact</b>								
Contact type	NO	NC	Lamp	NO	NC	Lamp		
Diagram								
Number of contacts	1	-	1	2	-	1		
<b>Description</b>	<b>Voltage (V AC/DC)</b>	<b>Color</b>	<b>Ordering No.</b>	<b>Qty</b>	<b>Voltage (V AC/DC)</b>	<b>Color</b>	<b>Ordering No.</b>	<b>Qty</b>
Selector switch, stay-put with lamp (SES-L)	24		6070303028	12	24		6070303032	12
			6070303029	12			6070303033	12
	220		6070303022	12		6070303024	12	
			6070303023	12		6070303025	12	
			6070303026	12		6070303027	12	
<b>Connection Capacity</b>								
Rigid Solid (mm <sup>2</sup> )				0.5-4				
Stripping Length (mm)				9				
Clamping Screw				M3				
Tightening Torque (N.m)				0.5				
<b>Insulation material</b>								
Height from the electrical panel surface (mm)				PA				
				26.50				



**Overall and Installation Dimension (mm) :**

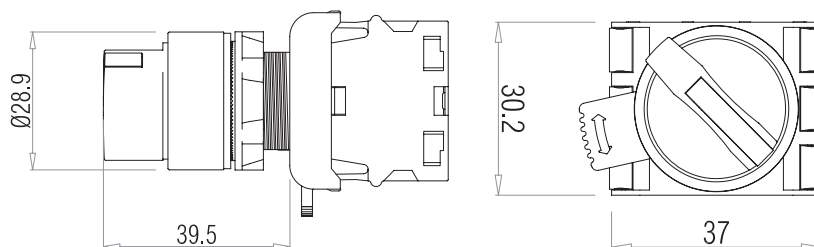



■ SESC2-L



■ SESC3-L



IEC 60947-5-1	SESC2-L			SESC3-L				
Impulse Voltage (kV)	4			4				
Rated Insulation Voltage (V)	400			400				
Current (A)	3			3				
Pollution Degree/Voltage Category/Material Group	3/III/I			3/III/I				
Utilization Category	AC-15, DC-13			AC-15, DC-13				
Ambient Temperature (°C)	-20 ~ +70			-20 ~ +70				
Type of position	 Two position stay-put			 Three position stay-put				
<b>Contact</b>								
Contact type	NO	NC	Lamp	NO	NC	Lamp		
Diagram								
Number of contacts	1	-	1	2	-	1		
<b>Description</b>	<b>Voltage (V AC/DC)</b>	<b>Color</b>	<b>Ordering No.</b>	<b>Qty</b>	<b>Voltage (V AC/DC)</b>	<b>Color</b>	<b>Ordering No.</b>	<b>Qty</b>
Selector switch, stay-put, coated with lamp (SESC-L)	220		6070303122	12	220		6070303124	12
			6070303123	12			6070303125	12
			6070303127	12			6070303126	12
<b>Connection Capacity</b>								
Rigid Solid (mm <sup>2</sup> )				0.5-4				
Stripping Length (mm)				9				
Clamping Screw				M3				
Tightening Torque (N.m)				0.5				
<b>Insulation material</b>								
Height from the electrical panel surface (mm)				PA				
				26.50				

**Overall and Installation Dimension (mm) :**

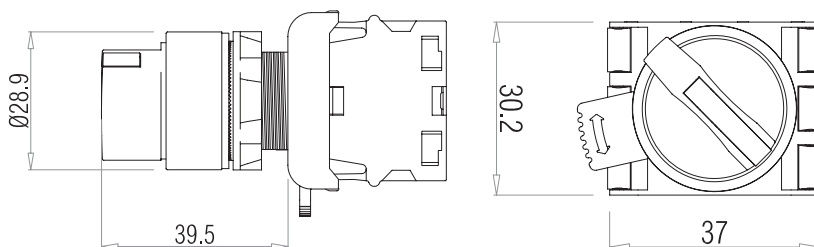

## Flush Buttons Protection cover (C-FB)



C-FB is a protection cover used as an encase made of silicone rubber material offering further protection from chemicals, oil, etc. This accessory's applications and details can be found in the following table.

Type	Ordering No.	Application	Material	Color	Qty.
C-FB	6070306008	FB-O, FB-C, FBC-O, FBC-C FBL-O, FBL-C, FBCL-O, FBCL-C	Silicon Rubber	Transparent	50

## Double Push Buttons Protection cover (C-DPB)



C-DPB is a protection covers used as an encase made of silicone rubber material offering further protection from chemicals, oil, etc. This accessory's applications and details can be found in the following table.

Type	Ordering No.	Application	Material	Color	Qty.
C-DPB	6070306009	DPB, DPBC, DPBL, DPBCL	Silicon Rubber	Transparent	50

## Emergency-button Guard (G-ESTR)



G-ESTR is a guard for preventing the unwanted touch of ESTR

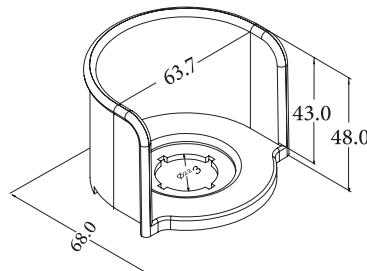

Type	Ordering No.	Application	Material	Qty.
G-ESTR	6070306007	ESTR	PA	5



■ RNCC



■ RNOC



■ RSC



IEC 60947-5-1	RNCC		RNOC		RSC
Diagram					
Utilization category	AC-15 / DC-13				-
Rated insulation voltage (V)	400				400
Rated operational Voltage (V)	250 (DC)	380 (AC)	240 (AC)	120 (AC)	Refer to Page 184
Rated operational current (A)	0.27 (DC)	1.9 (AC)	3 (AC)	6 (AC)	Refer to Page 184
Conventional free air thermal current (A)					10
Pollution Degree/VoltageCategory/Material Group					3/III/I

Description	Voltage (v)	Ordering No.	Qty.
Single normally open contact	Up to 380V	6070401001	50
Single normally close contact		6070402001	50
Single lamp contact		6070403001	50
Connection Capacity			
Rigid Solid (mm <sup>2</sup> )		0.5-4	
Stripping Length (mm)		9	
Clamping Screw		M3	
Tightening Torque (N.m)		0.5	
Insulation material		PA	

Overall and Installation Dimension (mm) :

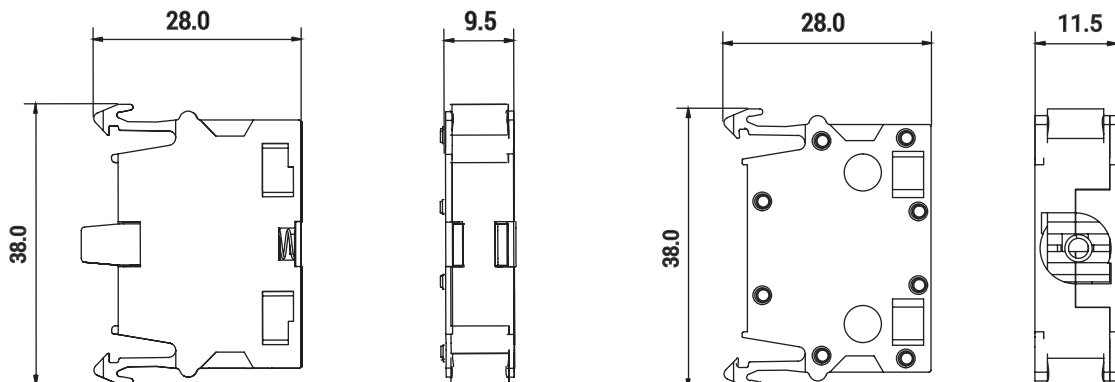



**RAAD**  <sup>®</sup> Electrical Connection for  
Technological Components  
*Confidence in Connection*

# Panel Signal Lights



- The range of 22mm diameter Panel Signal Lights is designed in accordance with IEC 60947-5-1 and IEC 60947-5-5 standards
- Easy and rapid installation
- Made of flame resistant material
- Provided in different colors and voltage levels
- The amount of exposure suitable for use in the industry
- It has two designs with a fixed PCB (IN22) and a interchangeable lamp (RSL22)
- RSL22 Certified by KEMA company



IN 22  
CE



RSL 22  
KEMA CE

IEC 60947-5-1	IN 22				RSL 22			
Light source	fixed				Interchangeable			
Max current (mA)	20				-			
Max power dissipation (W)	-				2.4			
Pollution Degree/Voltage Category/Material Group	3/III/1				3/III/1			
Ambient Temperature (°C)	-5~40				-5~40			
Description	Voltage	Color	Ordering Number	Qty.	Voltage	Color	Ordering Number	Qty.
Panel Signal lights	24V AC/DC	Blue	6070105001	25	24V AC/DC	Blue	6070110001	25
	24V AC/DC	Green	6070105002	25	24V AC/DC	Green	6070110002	25
	24V AC/DC	White	6070105003	25	24V AC/DC	White	6070110003	25
	24V AC/DC	Yellow	6070105004	25	24V AC/DC	Yellow	6070110004	25
	24V AC/DC	Red	6070105005	25	24V AC/DC	Red	6070110005	25
	110V AC/DC	Blue	6070103001	25	48V AC/DC	Blue	6070120001	25
	110V AC/DC	Green	6070103002	25	48V AC/DC	Green	6070120002	25
	110V AC/DC	White	6070103003	25	48V AC/DC	White	6070120003	25
	110V AC/DC	Yellow	6070103004	25	48V AC/DC	Yellow	6070120004	25
	110V AC/DC	Red	6070103005	25	48V AC/DC	Red	6070120005	25
	220V AC	Blue	6070102401	25	110V AC/DC	Blue	6070130001	25
	220V AC	Green	6070102402	25	110V AC/DC	Green	6070130002	25
	220V AC	White	6070102403	25	110V AC/DC	White	6070130003	25
	220V AC	Yellow	6070102404	25	110V AC/DC	Yellow	6070130004	25
	220V AC	Red	6070102405	25	110V AC/DC	Red	6070130005	25
	220V DC	Blue	6070102421	25	220V AC/DC	Blue	6070140001	25
	220V DC	Green	6070102422	25	220V AC/DC	Green	6070140002	25
	220V DC	White	6070102423	25	220V AC/DC	White	6070140003	25
220V DC	Yellow	6070102424	25	220V AC/DC	Yellow	6070140004	25	
220V DC	Red	6070102425	25	220V AC/DC	Red	6070140005	25	
Connection Capacity								
Rigid Solid (mm <sup>2</sup> )					0.5-4			
Stripping Length (mm)					9			
Clamping Screw					M3			
Tightening Torque (N.m)					0.5			
Insulation material					PA			
Height from the electrical panel surface (mm)					10			

**Overall and Installation Dimension (mm) :**

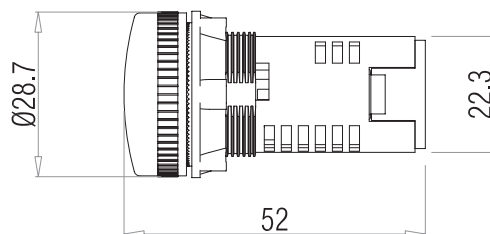



■ RCI 22

CE

IEC 60947-5-1		RCI 22		
Light source	fixed			
Max current (mA)	20			
Pollution Degree/Voltage Category/Material Group	3/III/I			
Ambient Temperature (°C)	-5~40			
Description	Voltage	Color	Ordering Number	Qty.
Panel Signal lights	24V AC/DC	Yellow	6070150001	25
	24V AC/DC	Green	6070150002	25
	24V AC/DC	Blue	6070150003	25
	24V AC/DC	White	6070150004	25
	24V AC/DC	Red	6070150005	25
	48V AC/DC	Blue	6070160001	25
	48V AC/DC	Yellow	6070160002	25
	48V AC/DC	Green	6070160003	25
	48V AC/DC	White	6070160004	25
	48V AC/DC	Red	6070160005	25
	110V AC/DC	Blue	6070170001	25
	110V AC/DC	Yellow	6070170002	25
	110V AC/DC	Green	6070170003	25
	110V AC/DC	White	6070170004	25
	110V AC/DC	Red	6070170005	25
	220V DC	Blue	6070180006	25
	220V DC	Yellow	6070180007	25
	220V DC	Green	6070180008	25
	220V DC	White	6070180009	25
	220V DC	Red	6070180010	25
220V AC	Blue	6070180001	25	
220V AC	Yellow	6070180002	25	
220V AC	Green	6070180003	25	
220V AC	White	6070180004	25	
220V AC	Red	6070180005	25	
Connection Capacity				
Rigid Solid (mm <sup>2</sup> )	0.5-4			
Stripping Length (mm)	9			
Clamping Screw	M3			
Tightening Torque (N.m)	0.5			
Insulation material	PA			
Height from the electrical panel surface (mm)	14			

Overall and Installation Dimension (mm) :

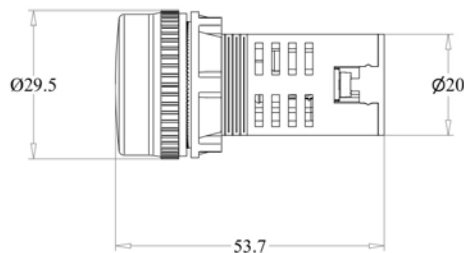



■ Lamp

CE

IEC 60947-5-1		Lamp			
Diagram					
Pollution Degree/Voltage Category/Material Group		3/III/1			
Ambient Temperature (°C)		-5~40			
Description	Voltage (V AC/DC)	Color	Power (W)	Ordering No.	Qty
BA9S/M-W 24VAC/DC	24		0.17	6070204001	25
BA9S/M-W 48VAC/DC	48		0.41	6070204002	25
BA9S/M-W 110VAC/DC	110		0.44	6070204003	25
BA9S/M-W 220VAC/DC	220		0.48	6070204004	25
BA9S/M-G 24VAC/DC	24		0.17	6070205001	25
BA9S/M-G 48VAC/DC	48		0.41	6070205002	25
BA9S/M-G 110VAC/DC	110		0.44	6070205003	25
BA9S/M-G 220VAC/DC	220		0.48	6070205004	25
BA9S/M-R 24VAC/DC	24		0.17	6070206001	25
BA9S/M-R 48VAC/DC	48		0.41	6070206002	25
BA9S/M-R 110VAC/DC	110		0.44	6070206003	25
BA9S/M-R 220VAC/DC	220		0.48	6070206004	25
BA9S/M-B 24VAC/DC	24		0.17	6070207001	25
BA9S/M-B 48VAC/DC	48		0.41	6070207002	25
BA9S/M-B 110VAC/DC	110		0.44	6070207003	25
BA9S/M-B 220VAC/DC	220		0.48	6070207004	25
BA9S/M-Y 24VAC/DC	24		0.17	6070208001	25
BA9S/M-Y 48VAC/DC	48		0.41	6070208002	25
BA9S/M-Y 110VAC/DC	110		0.44	6070208003	25
BA9S/M-Y 220VAC/DC	220		0.48	6070208004	25

Overall and Installation Dimension:

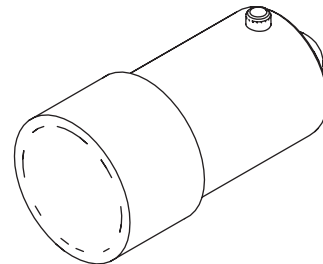
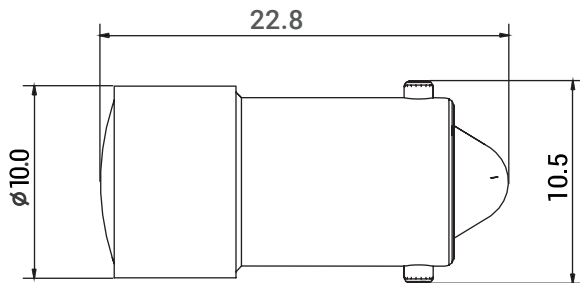





**RAAD**  <sup>®</sup> Electrical Connection for  
Technological Components  
*Confidence in Connection*

# Crimping Terminal



Tbloc Accessories for the Basket of Crimp Terminal Products are Presented by Three Distinct Types Including Ferrule, Connector and Lug.

- Accessories in **Ferrule** type are presented by three distinct categories as follows.
  - Non-insulated Cord End
  - Cord End
  - Twin Cord End
- Accessories in **Connector** type are presented by five distinct categories as follows.
  - Male Bullet
  - Female Bullet
  - Male Slip-on
  - Female Slip-on
  - Fully-Insulated Female Slip-on
- Accessories in **Lug** type are presented by three distinct categories as follows.
  - Butt
  - Ring
  - Spade

# Ferrule

Tbloc's Accessories in ferrule type are presented by three distinct category including Non-insulated Cord End, Cord End and Twin Cord End.



## Non-insulated Cord End

Tbloc non-insulated cord end ferrule is made from tin-plated copper. They ensure a reliable connection when wires are connected to terminal blocks and captive terminals.

TBloc Name	Ordering No.	Dimension (mm)				Cable Size (mm <sup>2</sup> )	Qty.
		L	D $\Phi$	C $\Phi$	W		
ES 0,50/10 E	8017435220	10.0	1.3	1.0	1.7	0.5	100
ES 0,75/10 E	8017435230	10.0	1.6	1.3	2.2	0.75	100
ES 1,0/10 E	8017435240	10.0	1.8	1.5	2.3	1.0	100
ES 1,5/10 E	8017435250	10.0	2.1	1.8	2.5	1.5	100
ES 1,5/8 E	8017435258	8.0	2.1	1.8	2.5	1.5	100
ES 2,5/12 E	8017435260	12.0	2.6	2.3	3.2	2.5	100
ES 2,5/8 E	8017435268	8.0	2.6	2.3	3.2	2.5	100
ES 4,0/12 E	8017435270	12.0	3.2	2.8	3.9	4.0	100
ES 6,0/12 E	8017435280	12.0	3.9	3.5	4.8	6.0	100
ES 10,0/15 E	8017435290	15.0	4.9	4.5	5.8	10.0	100
ES 16,0/15 E	8017435300	15.0	6.2	5.8	7.2	16.0	100
ES 25,0/16 E	8017435310	16.0	7.9	7.5	9.2	25.0	100
ES 35,0/16 E	8017435320	16.0	8.7	8.3	10.2	35.0	100
ES 50,0/20 E	8017435330	20.0	10.9	10.5	12.6	50.0	100

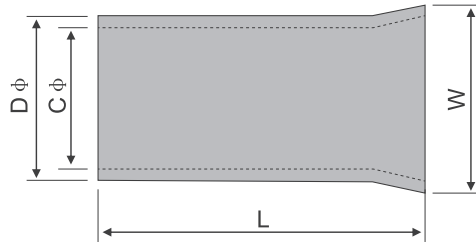

ES □/□ E

ES= Non-Insulated End Sleeve

Cable Size (mm<sup>2</sup>)= 0,50 ... 50,0

Contact Length (mm)= 8 ... 20

## Cord End



Tbloc Insulated cord end ferrule, ensures a reliable connection when wires are connected to captive terminals and terminal blocks. The ferrule has a tin plated copper tube. The insulation is color coded to provide quick identification of the terminal size as well as the protection to the terminal. Insulation sleeve of the insulated cord end ferrules is made from PA66. The insulation voltage,  $U_i$ , is 300V.

TBloc Name	Ordering No.	Dimension (mm)					Cable Size (mm <sup>2</sup> )	Color	Qty.
		F	L	W	D $\Phi$	C $\Phi$			
IES 0,50/8 E White	8017435005	8.0	14.4	2.6	1.3	1.0	0.5		100
IES 0,75/8 E Blue	8017435015	8.0	14.4	2.8	1.6	1.3	0.75		100
IES 1,0/8 E Red	8017435025	8.0	14.4	3.0	1.8	1.5	1.0		100
IES 1,5/8 E Black	8017435035	8.0	14.4	3.3	2.1	1.8	1.5		100
IES 2,5/8 E Gray	8017435045	8.0	15.8	4.0	2.6	2.3	2.5		100
IES 4,0/9 E Orange	8017435155	9.0	17.0	4.8	3.2	2.8	4.0		100
IES 6,0/12 E Green	8017435065	12.0	20.2	6.1	3.9	3.5	6.0		100
IES 10,0/12 E Brown	8017435075	12.0	21.5	7.4	4.9	4.5	10.0		100
IES 16,0/12 E Beige	8017435085	12.0	22.2	8.5	6.2	5.8	16.0		100
IES 25,0/16 E Black	8017435095	16.0	28.0	11.0	7.9	7.5	25.0		100
IES 35,0/16 E Red	8017435105	16.0	30.0	12.3	8.7	8.3	35.0		100
IES 50,0/20 E Blue	8017435115	20.0	36.0	14.8	10.9	10.3	50.0		100

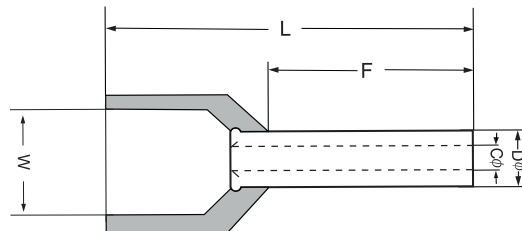

IES □/□ E □

**IES = Insulated End Sleeve**

Cable Size (mm<sup>2</sup>) = **0,50 ... 50,0**

**Color:**

White  
Blue  
Red  
Black  
Gray  
Orange  
Green  
Brown  
Beige  
Black  
Red  
Blue

Contact Length (mm) = **8 ... 20**

## Twin Cord End



TBloc twin cord end ferrules, provide an economical and effective method of terminating multi-stranded wires. Insulation sleeve accepts two multi-stranded wires. They ensure a reliable connection when wires are connected to terminal blocks and captive terminals. These ferrules have a tin plated copper tube with a color coded insulation sleeve made from PA66. The insulation voltage,  $U_i$ , is 300V.

TBloc Name	Ordering No.	Dimension (mm)						Cable Size (mm <sup>2</sup> )	Color	Qty.
		F	L	W	B	D $\phi$	C $\phi$			
IES 2x0,50/8 E White	8017435405	8.0	15.0	5.0	7.0	1.8	1.5	2*0.5		100
IES 2x0,75/8 E Blue	8017435415	8.0	15.8	5.3	7.8	2.1	1.8	2*0.75		100
IES 2x1,0/8 E Red	8017435425	8.0	16.0	5.3	8.0	2.4	2.1	2*1.0		100
IES 2x1,5/8 E Black	8017435435	8.0	16.5	6.2	8.5	2.6	2.3	2*1.5		100
IES 2x2,5/10 E Gray	8017435445	10.0	19.8	7.8	9.8	3.3	2.9	2*2.5		100
IES 2x4,0/12 E Orange	8017435455	12.0	22.2	8.5	10.2	4.2	3.8	2*4.0		100
IES 2x6,0/14 E Green	8017435465	14.0	25.2	9.5	11.2	5.3	4.9	2*6.0		100
IES 2x10,0/14 E Brown	8017435475	14.0	26.0	12.6	12.1	6.9	6.5	2*10.0		100
IES 2x16,0/14 E Beige	8017435485	14.0	30.3	19.0	16.3	8.7	8.3	2*16.0		100

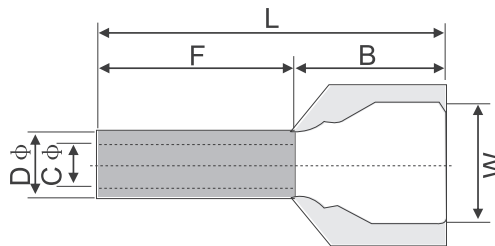

IES 2x □/□ E □

IES 2x = Twin Insulated Cord End Sleeve

Cable Size (mm<sup>2</sup>) = 0,50 ... 16,0

**Color:**

White  
Blue  
Red  
Black  
Gray  
Orange  
Green  
Brown  
Beige

Contact Length (mm) = 8 ... 14

# Connector

Tbloc's Accessories in Connector type are presented by five distinct category including Male Bullet, Female Bullet, Male Slip-on, Female Slip-on and Fully-Insulated Female Slip-on.



## Male Bullet

Tbloc Bullet Connectors are designed to provide reliable and easy connection/disconnection. The insulation part of the male bullet connector is made from the high quality PVC. The conductive part of the connector is produced by highly conductive brass.

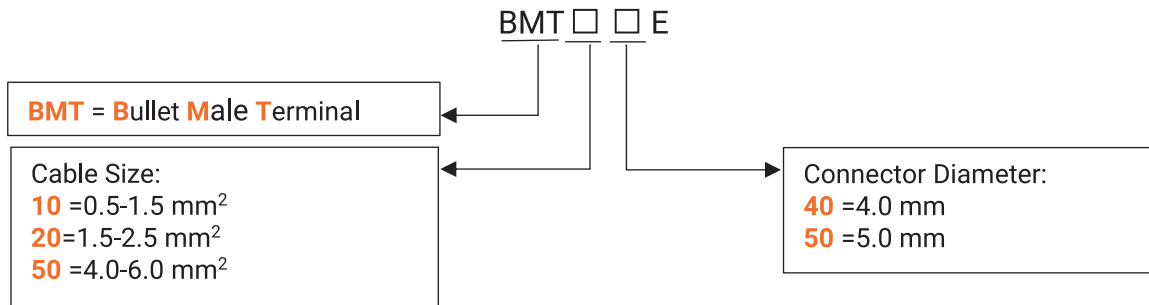
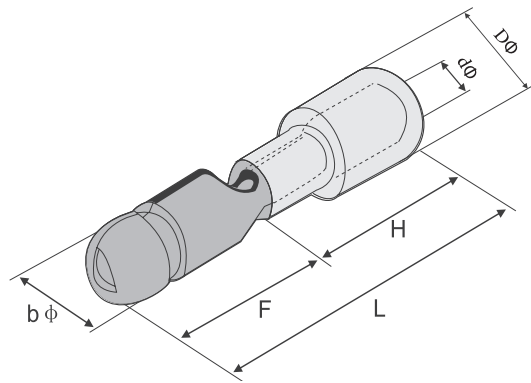

TBloc Name	Ordering No.	Dimension (mm)						Cable Size (mm <sup>2</sup> )	I <sub>Max</sub>	Color	Qty.
		bΦ	L	F	DΦ	H	dΦ				
BMT 1040 E	8018436700	4.0	21.5	11.0	3.8	10.5	1.8	0.5- 1.5	10.0	Red	100
BMT 2050 E	8018436710	5.0	20.8	10.3	4.3	10.5	2.3	1.5- 2.5	15.0	Blue	100
BMT 5050 E	8018436720	5.0	25.2	11.7	5.4	13.5	3.6	4.0-6.0	24.0	Yellow	100



## Female Bullet



Tbloc Bullet Connectors are designed to provide reliable and easy connection/disconnection. The female bullet connector is fully insulated with high-quality PVC. The conductive part of the connectors are produced by highly conductive brass.

Tbloc Name	Ordering No.	Dimension (mm)						Cable Size (mm <sup>2</sup> )	I <sub>Max</sub>	Color	Qty.
		bΦ	L	F	DΦ	H	dΦ				
BFT 1040 E	8018436600	4.0	24.0	12.5	3.8	11.5	1.8	0.5-1.5	10.0		100
BFT 2050 E	8018436610	5.0	24.0	13.5	4.3	10.5	2.3	1.5-2.5	15.0		100
BFT 5050 E	8018436620	5.0	24.0	13.5	5.4	10.5	3.6	4.0-6.0	24.0		100

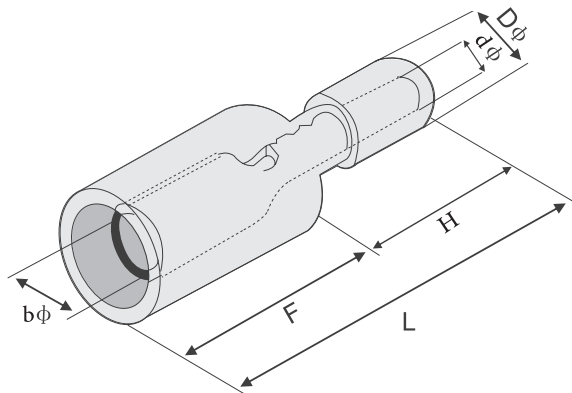

BFT □ □ E

**BFT** = Bullet Female Terminal

Cable Size:

**10** = 0.5-1.5 mm<sup>2</sup>

**20** = 1.5-2.5 mm<sup>2</sup>

**50** = 4.0-6.0 mm<sup>2</sup>

Connector Diameter:

**40** = 4.0 mm

**50** = 5.0 mm

## Male Slip-On



Easy and quick connection/disconnection are provided by Tbloc slip-on connectors. The male slip-on connectors are produced by highly conductive brass. The insulation of these connectors are made from PVC and coded relating to the wire used with.

TBloc Name	Ordering No.	Dimension (mm)					Cable Size (mm <sup>2</sup> )	I <sub>Max</sub>	Color	Qty.
		D $\phi$	L	B	d $\phi$	H				
FMT 1638 E	8018436170	3.8	21.5	6.35	1.8	10.5	0.5- 1.5	10.0	<span style="color: red;">■</span>	100
FMT 2488 E	8018436180	4.8	20.5	4.75	2.3	10.5	1.5- 2.5	15.0	<span style="color: blue;">■</span>	100
FMT 2638 E	8018436190	4.3	21.5	6.35	2.3	10.5				100

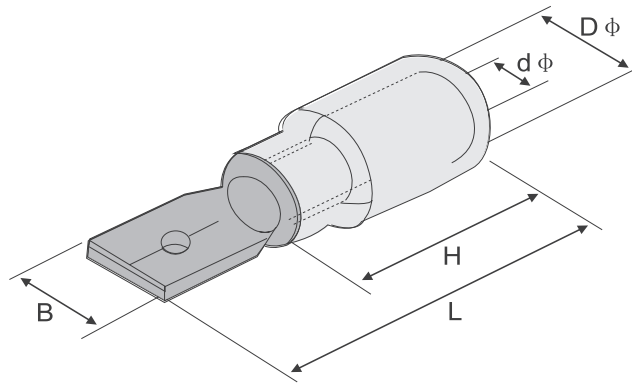

FMT □ □ E

**FMT** = Fast-on **M**ale **T**erminal

Cable Size:  
**1** = 0.5-1.5 mm<sup>2</sup>  
**2** = 1.5 -2.5 mm<sup>2</sup>

Connector Width:  
**488** = 4.88 mm  
**638** = 6.38 mm

## Female Slip-On



Easy and quick connection/disconnection are provided by Tbloc slip-on connectors. The female slip-on connector or receptacle is crimped onto the end of the stranded electrical wire without soldering. These connectors are produced by highly conductive brass. Also the insulation of the connector is made from PVC.

TBloc Name	Ordering No.	Dimension (mm)					Cable Size (mm <sup>2</sup> )	I <sub>Max</sub>	Color	Qty.
		dΦ	L	B	DΦ	H				
FFT 1638 E	8018436110	1.8	20.5	6.6	3.8	10.5	0.5- 1.5	10.0	<span style="color: red;">■</span>	100
FFT 2488 E	8018436120	2.3	19.5	5.0	4.3	10.5	1.5- 2.5	15.0	<span style="color: blue;">■</span>	100
FFT 2638 E	8018436130	2.3	20.5	6.6	4.3	10.5				100
FFT 5638 E	8018436140	3.6	23.5	6.6	5.4	13.5	4.0- 6.0	24.0	<span style="color: yellow;">■</span>	100

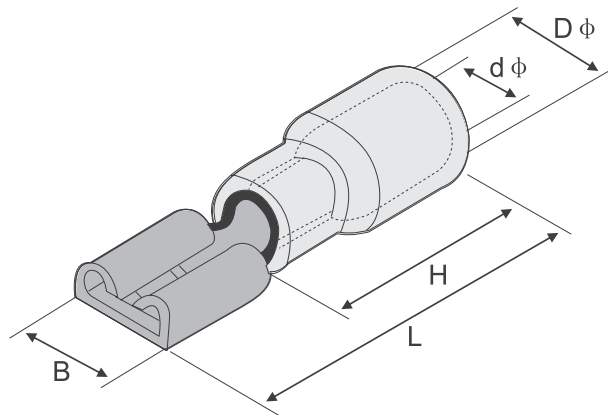

FFT □ □ E

FFT = Fast-on Female Terminal



Cable Size:  
**1** =0.5 -1.5 mm<sup>2</sup>  
**2** =1.5 -2.5 mm<sup>2</sup>  
**5** =4.0-6.0 mm<sup>2</sup>

Connector Width:  
**488** =4.88 mm  
**638** =6.38 mm

# Fully-Insulated Female Slip-On



Easy and quick connection/disconnection are provided by Tbloc slip-on connectors. The fully insulated female slip-on connector protects electrical connection and prevents shorting from exposed leads of connectors. These connectors are produced by highly conductive brass. Also, the insulation of the connector is produced by PVC.

TBloc Name	Ordering No.	Dimension (mm)				Cable Size (mm <sup>2</sup> )	I <sub>Max</sub>	Color	Qty.
		dΦ	L	B	DΦ				
IFFT 1288 E	8018436300	1.8	20.0	3.2	3.8	0.5-1.5	10.0		100
IFFT 1488 E	8018436310	1.8	20.0	5.0	3.8				100
IFFT 1638 E	8018436320	1.8	22.5	6.6	3.8				100
IFFT 2288 E	8018436325	2.3	20.5	3.2	4.2	1.5-2.5		100	
IFFT 2488 E	8018436330	2.3	20.5	5.0	4.2			100	
IFFT 2638 E	8018436340	2.3	23.5	6.6	4.2			100	
IFFT 5638 E	8018436350	3.6	24.0	6.6	5.7	4.0-6.0	24.0		100

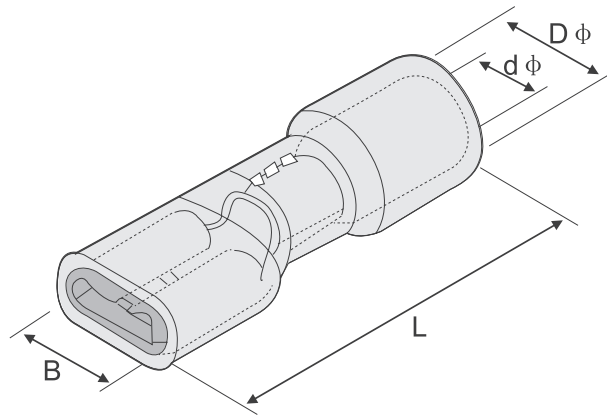

IFFT □ □ E

IFFT = Insulated Fast-on Female Terminal

Cable Size:  
**1** = 0.5 - 1.5 mm<sup>2</sup>  
**2** = 1.5 - 2.5 mm<sup>2</sup>  
**5** = 4.0 - 6.0 mm<sup>2</sup>

Connector Width:  
**288** = 2.88 mm  
**488** = 4.88 mm  
**638** = 6.38 mm

# Lug

Tbloc's Accessories in cable lug type is presented by three distinct category including Butt, Ring and Spade.

## Butt



Tbloc butt cable lugs also known as insulated crimp butt splice terminals are designed for crimping electrical wires and act as the solderless cable joint. The tube-shaped of these cable lugs allows electrical current to flow safely from one wire to another. Tbloc butt cable lugs are used to lengthen electrical circuits. These butt cable lugs are produced by highly conductive copper with Matt-Tin plating to ensure maximum electrical conductivity. The color coded PVC insulation provides quick identification of the terminal size as well as the protection to the terminal.

TBloc Name	Ordering No.	Dimension (mm)				Cable Size (mm <sup>2</sup> )	I <sub>Max</sub>	Color	Qty.
		L	I	dΦ	DΦ				
IBT 251 E	8018436500	25.0	15.0	2.0	4.3	0.5- 1.5	19.0	Red	100
IBT 252 E	8018436510	25.0	15.0	2.6	5.0	1.5- 2.5	27.0	Blue	100
IBT 256 E	8018436520	25.0	15.0	3.5	6.5	4.0-6.0	48.0	Yellow	100

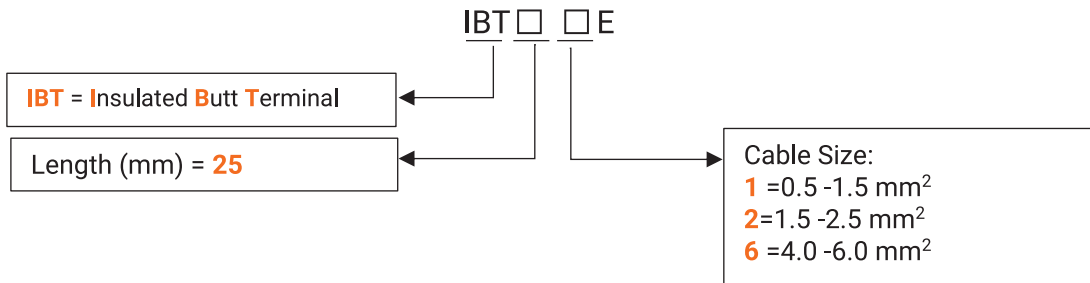
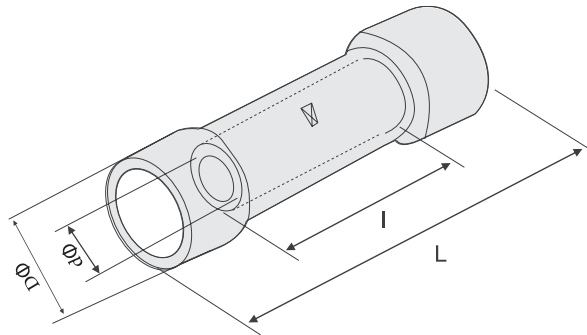



## Ring

Tbloc ring cable lugs, are used for connecting a wire or electrical cable to a stud or a post on an electrical component such as a battery terminal. The lug is produced by highly conductive copper with Matt-Tin plating to ensure maximum electrical conductivity. The color coded PVC insulation provides quick identification of the terminal size and protection to the terminal.

TBloc Name	Ordering No.	Screw USA	Dimension (mm)						D $\phi$	d $\phi$	Cable Size (mm <sup>2</sup> )	I <sub>Max</sub>	Color	Qty.
			d2 $\phi$	B	L	F	H							
IRT 301 E	8018435500	#4	3.2	5.7	18.8	5.0	11.0	4.3	1.7	0.5-1.5	19.0	■	100	
IRT 351 E	8018435510	#6	3.7	5.7	17.8	4.95							100	
IRT 401 E	8018435520	#8	4.3	6.6	20.4	6.3							100	
IRT 501 E	8018435530	#10	5.3	8.0	21.5	7.0							100	
IRT 601 E	8018435540	1/4	6.4	11.6	27.8	11.1							100	
IRT 801 E	8018435550	5/16	8.4	11.6	27.8	11.1							100	
IRT 302 E	8018435560	#4	3.2	6.6	19.0	4.8	11.0	5.2	2.3	1.5-2.5	■	100		
IRT 402 E	8018435570	#8	4.3	6.6	20.4	6.2						100		
IRT 502 E	8018435580	#10	5.3	8.5	22.8	7.7						100		
IRT 602 E	8018435590	1/4	6.4	12.0	27.8	11.0						100		
IRT 802 E	8018435600	5/16	8.4	12.0	27.8	11.0						100		
IRT 1002 E	8018435610	3/8	10.5	13.6	31.5	14.0						100		
IRT 406 E	8018435620	#8	4.3	7.2	23.2	5.9	14.0	6.5	3.4	4.0-6.0	■	100		
IRT 506 E	8018435630	#10	5.3	9.5	26.7	8.3						100		
IRT 606 E	8018435640	1/4	6.4	12.0	30.2	10.6						100		
IRT 806 E	8018435650	5/16	8.4	15.0	34.8	13.7						100		
IRT 1006 E	8018435660	3/8	10.5	15.0	34.8	13.7						100		
IRT 1206 E	8018435670	1/2	13.0	19.3	39.5	16.5						100		
IRT 510 E	8018435680	#10	5.3	8.8	32.7	11.0	17.5	8.3	4.5	6.0-10.0	■	100		
IRT 610 E	8018435690	1/4	6.4	12.0	32.5	9.2						100		

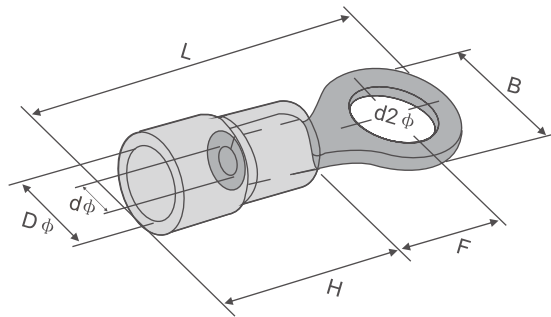

IRT □ □ E

IRT = Insulated Ring Terminal

Screw Diameter:

**30** = 3.0 mm      **60** = 6.0 mm  
**35** = 3.5 mm      **80** = 8.0 mm  
**40** = 4.0 mm      **100** = 10.0 mm  
**50** = 5.0 mm      **120** = 12.0 mm

Cable Size:

**1** = 0.5 - 1.5 mm<sup>2</sup>  
**2** = 1.5 - 2.5 mm<sup>2</sup>  
**6** = 4.0 - 6.0 mm<sup>2</sup>  
**10** = 6.0 - 10.0 mm<sup>2</sup>

# Spade



Tbloc insulated spade cable lugs are used to connect electrical wires with screws and studs safely and reliably. These ring cable lugs are produced by highly conductive copper with Matt-Tin plating to ensure maximum electrical conductivity. The color coded PVC insulation provides quick identification of the terminal size as well as the protection to the terminal.

Tbloc Name	Ordering No.	Screw USA	Dimension (mm)					H	DΦ	dΦ	Cable Size (mm <sup>2</sup> )	I <sub>Max</sub>	Color	Qty.
			d2Φ	B	L	F								
IFT 301 E	8018435700	#4	3.2	5.7	21.5	6.5	10.5	4.3	1.7	0.5-1.5	19.0	■	100	
IFT 401 E	8018435720	#8	4.3	6.4	21.5	6.5							100	
IFT 501 E	8018435730	#10	5.3	8.1	21.5	6.3							100	
IFT 601 E	8018435740	1/4	6.4	12.0	27.2	11.0							100	
IFT 352 E	8018435750	#4	3.2	5.7	21.5	6.5	10.5	4.8	2.3	1.5-2.5	27.0	■	100	
IFT 402 E	8018435760	#8	4.3	6.4	21.5	6.3							100	
IFT 502 E	8018435770	#10	5.3	9.4	21.5	6.3							100	
IFT 602 E	8018435780	1/4	6.4	12.0	27.5	11.0							100	
IFT 406 E	8018435790	#8	4.3	8.3	26.0	7.5	13.5	6.3	3.4	4.0-6.0	48.0	■	100	
IFT 506 E	8018435800	#10	5.3	9.0	26.0	7.5							100	
IFT 606 E	8018435810	1/4	6.4	9.0	26.0	7.0							100	
IFT 806 E	8018435820	5/16	8.4	14.0	31.0	11.0							100	

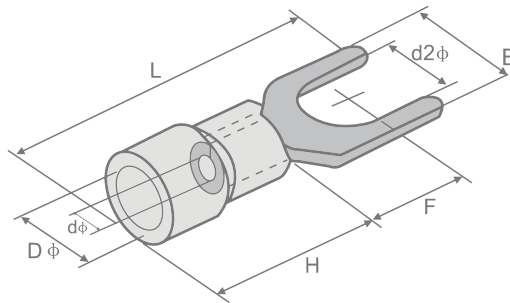

IFT □ □ E

**IFT = Insulated Fork Terminal**

Screw Diameter:  
**30** = 3.0 mm  
**35** = 3.5 mm  
**40** = 4.0 mm  
**50** = 5.0 mm  
**60** = 6.0 mm  
**80** = 8.0 mm

Cable Size:  
**1** = 0.5 - 1.5 mm<sup>2</sup>  
**2** = 1.5 - 2.5 mm<sup>2</sup>  
**6** = 4.0 - 6.0 mm<sup>2</sup>

## Kit

Tbloc Accessories for the Basket of Crimp Terminal Products are also presented by two Distinct Types Including Circular and Rectangular kits.

### Circular Kit



Tbloc Name	Ordering No.	Contents	Qty.
Circular Assortment 1	8017455480	IES 0,50/8 E White	50
		IES 0,75/8 E Blue	100
		IES 1,0/8 E Red	100
		IES 1.5/8 E Black	100
		IES 2.5/8 E Gray	50
Circular Assortment 2	8017455481	IES 2x0,50/8 E White	50
		IES 2x0,75/8 E Blue	50
		IES 2x1,0/8 E Red	50
		IES 2x1.5/8 E Black	50
		IES 2x2.5/10 E Gray	50
Circular Assortment 3	8017455482	IES 4,0/10 E Orange	50
		IES 6,0/12 E Green	20
		IES 10,0/12 E Brown	20
		IES 16,0/12 E Ivory	10

# Rectangular Kit



Tbloc Name	Ordering No.	Contents	Qty.
Rectangular Assortment 1	8018536721	IES 0,50/8 E White	200
		IES 0,75/8 E Blue	200
		IES 1,0/8 E Red	200
		IES 1.5/8 E Black	250
		IES 2.5/8 E Gray	250
		IES 4,0/9 E Orange	50
		IES 6,0/12 E Green	25
		IES 10,0/12 E Brown	25
Rectangular Assortment 2	8018536722	IES 0,50/8 E White	100
		IES 0,75/8 E Blue	100
		IES 1,0/8 E Red	100
		IES 1.5/8 E Black	100
		IES 2.5/8 E Gray	100
		IES 4,0/9 E Orange	50
		IES 6,0/12 E Green	25
		IES 2x0,50/8 E White	50
		IES 2x0,75/8 E Blue	50
		IES 2x1,0/8 E Red	50
IES 2x1.5/8 E Black	25		
IES 2x2.5/10 E Gray	25		

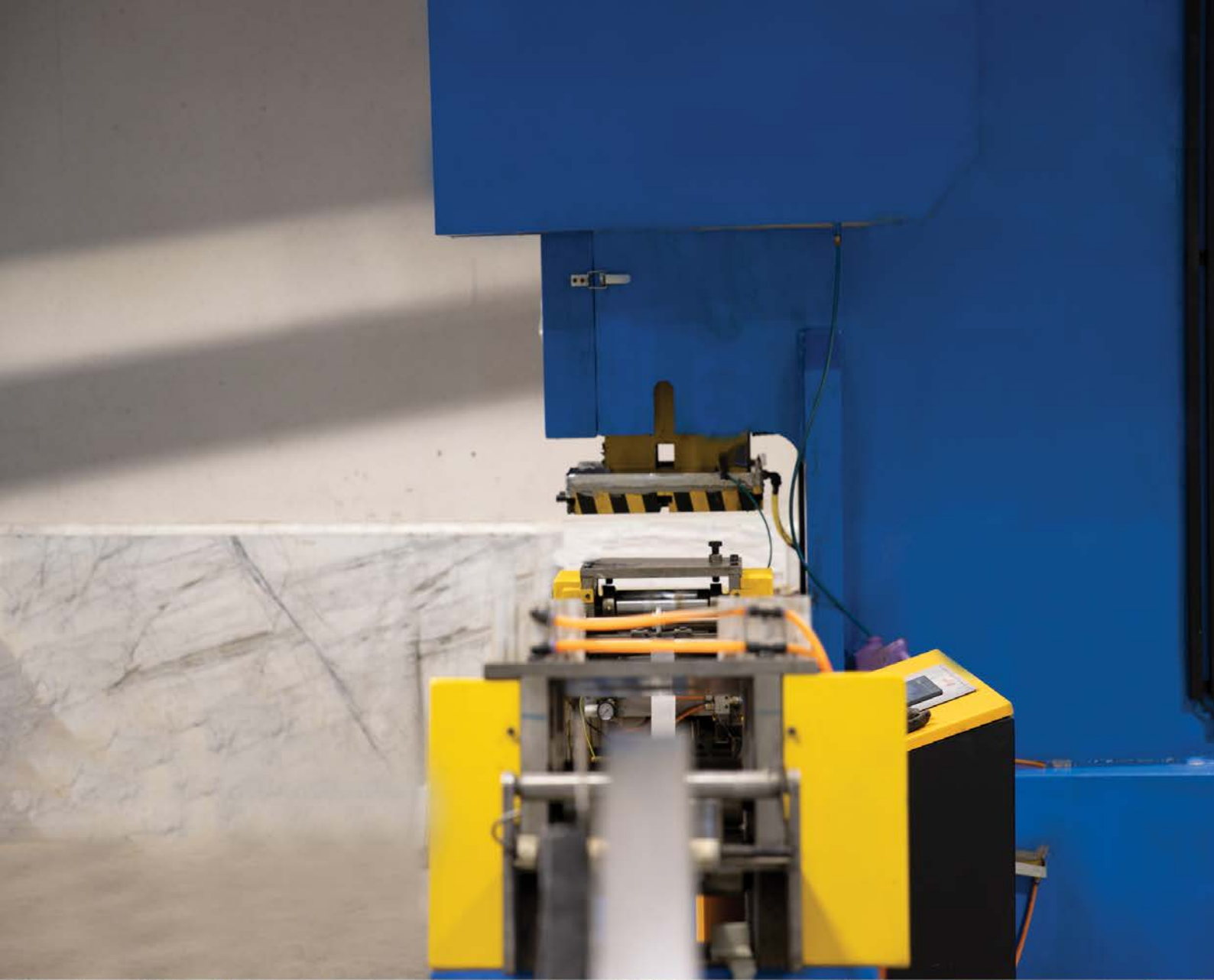

**RAAD**  <sup>®</sup> Electrical Connection for  
Technological Components

*Confidence in Connection*

# Marking Solution



RAAD's marking solution consist of below product portfolios:

- CM : Marking solution for cable marking with cable ties
- TBET : Marking accessories for control switches with 22 mm diameter
- TYPET: Self-adhesive panel labels holders for panel marking
- ASE60: Label of emergency stop button with 22 mm diameter labels
- TBSL: Strip label for group of terminal blocks

## CM

This product group includes holder and suitable paper for inserting information. The application of these products is for cable marking, which is placed on the cable by a cable tie.



Type	Ordering No.	Qty.	Dimension of print area (mm)
CM 1	8021334009	100	30×7
CM 2	8021334019	100	40×17

## TBET

This product group is for marking switch control products with a diameter of 22 mm. This product group has two products with two different sizes for printing information.



Type	Ordering No.	Qty.	Dimensions of print area (mm)
TBET 40×30	8022130330	60	8×25
TBET 50×30	8022130340	60	18×25

## TYPET

This product group will be used for equipment marking on the electrical panels. These products include a rectangular holder with a self-adhesive sticker with a paper that fits the dimensions of the holder.



Type	Ordering No.	Qty.	Dimension of print area (mm)
TYPET 17×75	8022130320	25	15×72
TYPET 17×50	8022130310	50	15×49
TYPET 17×30	8022130300	100	14×27

## ASE60

This product is used for marking emergency stop button products with a diameter of 22 mm.



Type	Ordering No.	Qty.	Dimensions of body	
			Label diameter (mm)	Hole diameter (mm)
ASE60	8022130350	1	60	23.5

## TBSL

This type of strip label is used in terminal blocks on a specific place in the body and can be printed by our thermal printers easily. The material of the strip is PVC which has an 11.2 mm width and is arranged in 2 rows in each roll. The length of strip label is 20 meters.



Type	Ordering No.	Qty.	Push-in terminal blocks	Applicable on		Accessories
				Screw terminal blocks		
TBSL 22x20	8020384009	1	RT/PG series	RT/SG series, RT/SU10-2L, RT/SU2.5-3LOE5, for other screw terminals use with marking holder		EB4, for other accessories use with marking holder



**RAAD**  <sup>®</sup> Electrical Connection for  
Technological Components  
*Confidence in Connection*

# Relay Modules

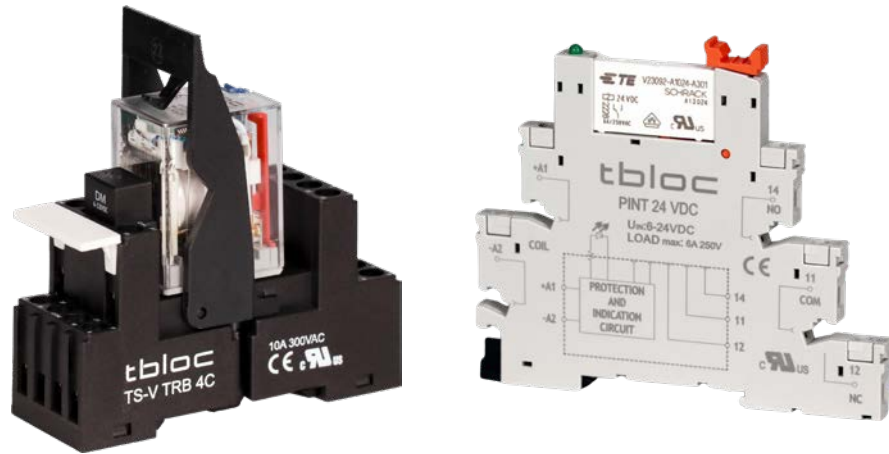

Electromechanical relays are a varied solution for a wide range of switching processes. They can be used for level and power adaptation and form interfaces between control, signaling and regulating equipment and peripherals. They can be easily integrated into a wide variety of circuit types.

TBLOC relay modules are offered in the following two groups in accordance with IEC 61810-1, IEC 61810-7 and IEC 61984:

- **TRB industrial relay modules** provide users with excellent reliability and service convenience. These relays design for all-purpose use in a wide range of industrial applications. Also these products are offered in different AC or DC voltage levels and are presented to the market in two and four change-over structures. The 27.2 mm wide TRB socket series is designed for industrial relays with up to 4 contacts. Currents up to 12 A are no problem for these sockets. This relay is ideal for applications that require power and signal multiplication.
- **PINT series** offer you, ability to work on complex systems with numerous sensor connections and the reliability of the actuator connections in terms of lifetime and speed. The narrow 6.3 mm PINT sockets is designed for miniature relays with one change-over contact. Switching currents up to 6 A and PINT module is therefore a good choice for all coupling applications. Also PINT module series design with 24 V DC and 230 V UC for input voltages.

## TRB LT series

TBLOC's TRB series relays have the following specifications:

- Two type of contact configuration including:
  - 2 change over contact configuration with 10A switching capacity
  - 4 change over contact configuration with 5A switching capacity
- Different levels of coil voltage including:
  - 12/24/48/110/220 V DC
  - 24/48/115/230V AC
- Blue test button for DC coil voltage and Red test button for AC coil voltage
- Red plastic flag
- Green LED coil statues indicating the state for DC coil voltage and Red LED for AC coil voltage
- Contact gold plating for better switching of low current loads
- Special contact material with high switching power to increase mechanical and electrical life
- UL and EAC certificates approved
- Compliant with IEC 61810-1 and IEC 61810-7 standards and CE low voltage directive
- Has accessories such as socket, relay holder on the socket and coil protection module

Tbloc TRB relay product selection guide is shown below:

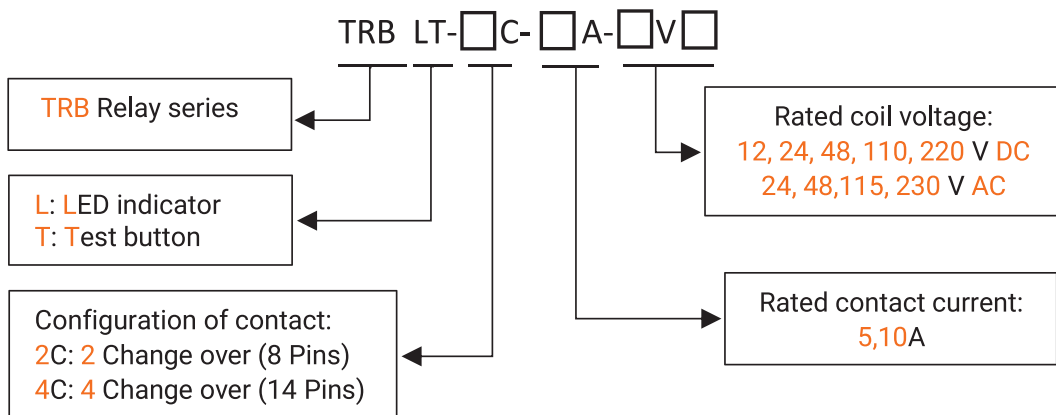





■ TRB LT-2C



## Technical data

### Coil specification and Ordering code

Type	Rated coil voltage	at +20°C		Coil resistance(Ω)	Coil consumption	Ordering No.	Qty.
		Pick-up voltage	Drop-out voltage				
TRB LT-2C-10A-12 V DC	12 VDC	9.0 Vdc	1.2 Vdc	160±10%	0.9 W	8036322000	20
TRB LT-2C-10A-24 V DC	24 VDC	18.0 Vdc	2.4 Vdc	650±10%	0.9 W	8036322010	20
TRB LT-2C-10A-48 V DC	48 VDC	36.0 Vdc	4.8 Vdc	2560±10%	0.9 W	8036322020	20
TRB LT-2C-10A-110 V DC	110 VDC	82.5 Vdc	11.0 Vdc	13400±10%	0.9 W	8036322030	20
TRB LT-2C-10A-220 V DC	220 VDC	165.0 Vdc	22.0 Vdc	53700±15%	0.9 W	8036322032	20
TRB LT-2C-10A-24 V AC	24 VAC	19.2 Vac	7.2 Vac	180±10%	1.2VA	8036322040	20
TRB LT-2C-10A-48 V AC	48 VAC	38.4 Vac	14.4 Vac	790±10%	1.2VA	8036322050	20
TRB LT-2C-10A-115 V AC	115 VAC	92.0 Vac	34.5 Vac	4550±15%	1.2VA	8036322060	20
TRB LT-2C-10A-230 V AC	230 VAC	184.0 Vac	69.0 Vac	15920±10%	1.2VA	8036322070	20

### Contact Specification

Contact configuration	2 Change-over
Contact rating	10A -250VAC / 30VDC
UL contact rating	10A – 250VAC / 30VDC 1/3HP@240VAC
Material	AgNi-Gold plated
Minimum current	10mA@12VDC
Maximum switching voltage	250 VAC / 30VDC @ 10A
Maximum switching power	2500VA / 300W @ 10A
Electrical life (Cycles)	>1x10 <sup>5</sup>
Mechanical life (Cycles)	>1x10 <sup>7</sup>

### Insulation

Rated insulation voltage (V)	250
Impulse voltage (kV(1.2/50µs))	4
	2.5
Pollution degree	2
Overvoltage category	II
Dielectric strength (1 min, 50/60Hz)	Between coil and contacts Between open contacts Between contact/contact
	2500 VAC (Vrms) 1000 VAC (Vrms) 2000 VAC (Vrms)
Insulation resistance (coil-contact circuit)	1000 MΩ (at 500.0VDC)

### General data

Operating time (at nominal voltage)	<20 ms max.
Release time (at nominal voltage)	<20 ms max.
Ambient temperature (°C)	-40 ~ +70
Vibration resistance (g)	10
Shock resistance(g)	Functional Destructive
	10 100
Humidity	5%~85% RH non-condensing
Terminals	PCB or Soldering Lugs (Plug-in)
Weight (g)	35

**Dimension (mm) :**

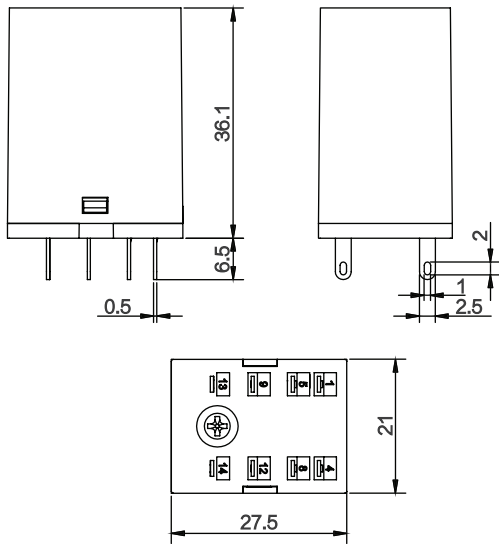

**Wiring diagram:**

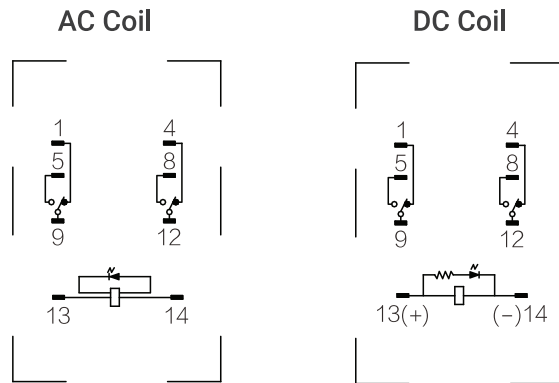

**Operating voltage range DC**

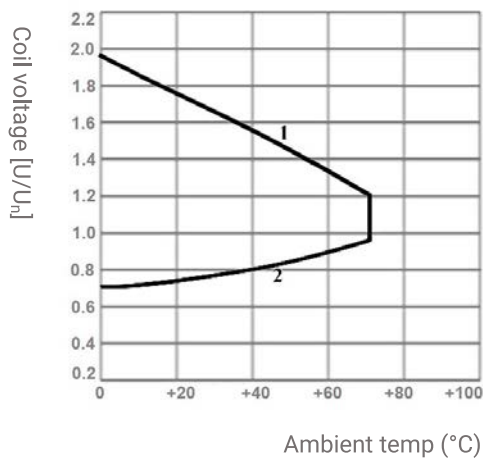

- 1- Max permitted coil voltage
- 2- Min pick-up voltage with coil at ambient temperature

**Operating voltage range AC**

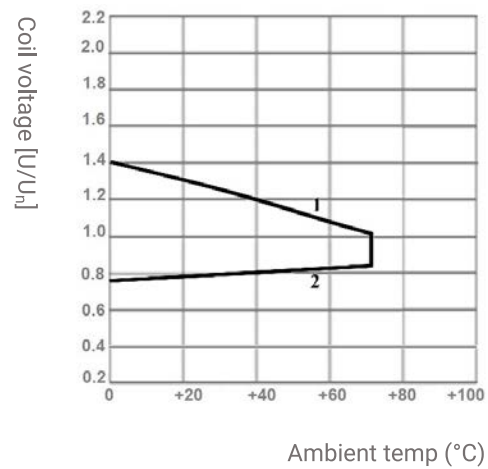

- 1- Max permitted coil voltage
- 2- Min pick-up voltage with coil at ambient temperature

**Maximum switching current**

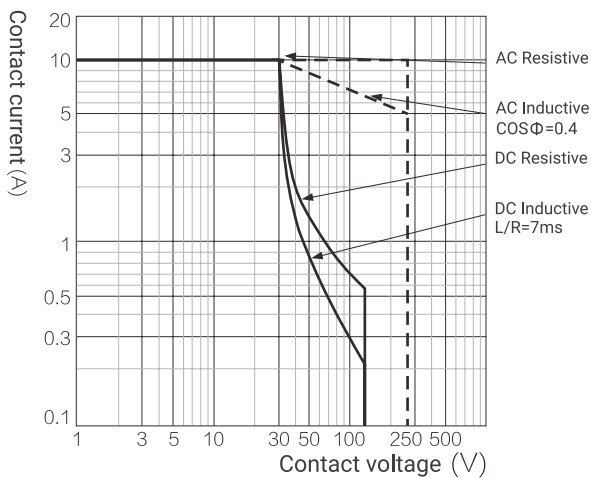

**Electrical endurance-Resistive load**

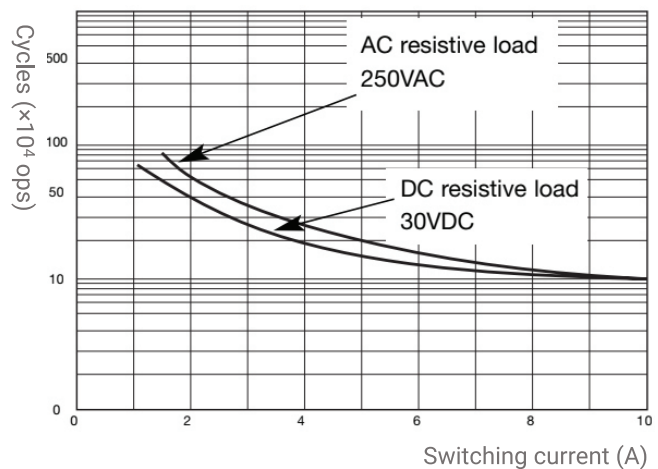

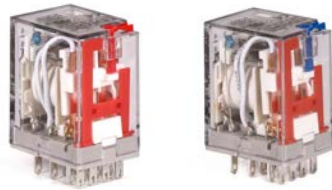

■ TRB LT-4C



## Technical data

### Coil specification and Ordering code

Type	Rated coil voltage	at +20°C		Coil resistance(Ω)	Coil consumption	Ordering No.	Qty.
		Pick-up voltage	Drop-out voltage				
TRB LT-4C-5A-12 V DC	12 VDC	9.0 Vdc	1.2 Vdc	160±10%	0.9 W	8036324500	20
TRB LT-4C-5A-24 V DC	24 VDC	18.0 Vdc	2.4 Vdc	650±10%	0.9 W	8036324510	20
TRB LT-4C-5A-48 V DC	48 VDC	36.0 Vdc	4.8 Vdc	2560±10%	0.9 W	8036324520	20
TRB LT-4C-5A-110 V DC	110 VDC	82.5 Vdc	11.0 Vdc	13400±10%	0.9 W	8036324530	20
TRB LT-4C-5A-220 V DC	220 VDC	165.0 Vdc	22.0 Vdc	53700±15%	0.9 W	8036324532	20
TRB LT-4C-5A-24 V AC	24 VAC	19.2 Vac	7.2 Vac	180±10%	1.2 VA	8036324540	20
TRB LT-4C-5A-48 V AC	48 VAC	38.4 Vac	14.4 Vac	790±10%	1.2 VA	8036324550	20
TRB LT-4C-5A-115 V AC	115 VAC	92.0 Vac	34.5 Vac	4550±15%	1.2 VA	8036324560	20
TRB LT-4C-5A-230 V AC	230 VAC	184.0 Vac	69.0 Vac	15920±10%	1.2 VA	8036324570	20

### Contact Specification

Contact configuration	4 Change-over
Contact rating	5A -250VAC / 30VDC
UL contact rating	5A - 250VAC/30VDC 1/6HP @ 240VAC
Material	AgNi-Gold pated
Minimum current	10mA@12VDC
Maximum switching voltage	250VAC / 30VDC @ 5A
Maximum switching power	1250VA / 150W @ 5A
Electrical life (Cycles)	1x10 <sup>5</sup>
Mechanical life (Cycles)	1x10 <sup>7</sup>

### Insulation

Rated insulation voltage (V)	250
Impulse voltage (kV(1.2/50μs))	Between coil and contact circuit Between contact/contact
	4 2.5
Pollution degree	2
Overtoltage category	II
Dielectric strength (1 min, 50/60Hz)	Between coil and contacts Between open contacts Between contact/contact
	2500 VAC (Vrms) 1000 VAC (Vrms) 2000 VAC (Vrms)
Insulation resistance (coil-contact circuit)	1000 MΩ (at 500.0VDC)

### General data

Operating time (at nominal voltage)	<20 ms max.
Release time (at nominal voltage)	<20 ms max.
Ambient temperature (°C)	-40 ~ +70
Vibration resistance (g)	10
Shock resistance(g)	Functional Destructive
	10 100
Humidity	5%~85% RH non-condensing
Terminals	PCB or Soldering Lugs (Plug-in)
Weight (g)	35

**Dimension (mm) :**

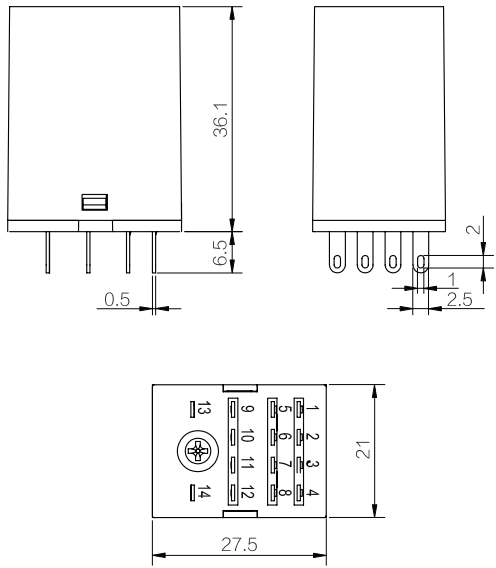

**Wiring diagram:**

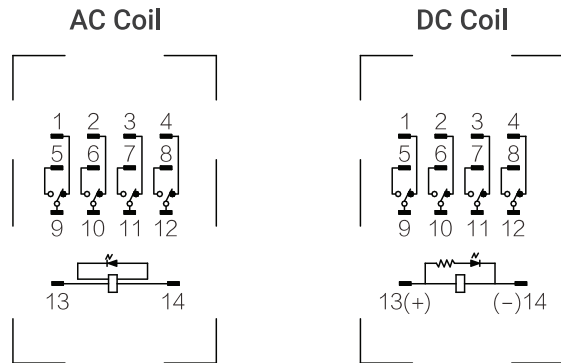

**Operating voltage range DC**

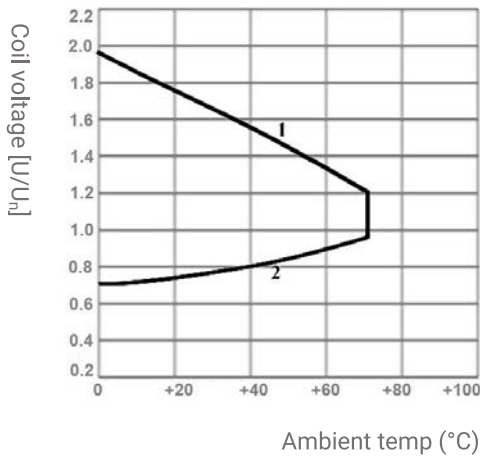

**Operating voltage range AC**

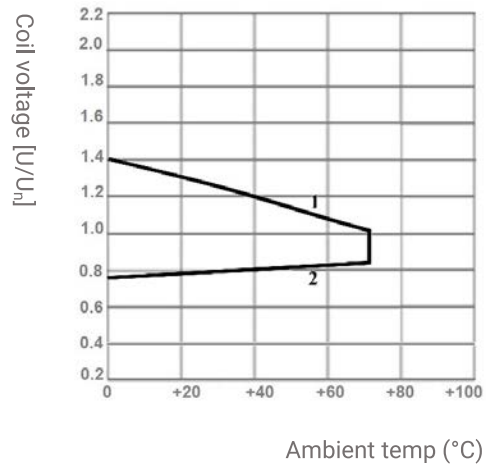

1- Max permitted coil voltage

1- Max permitted coil voltage

2- Min pick-up voltage with coil at ambient temperature

2- Min pick-up voltage with coil at ambient temperature

**Maximum switching current**

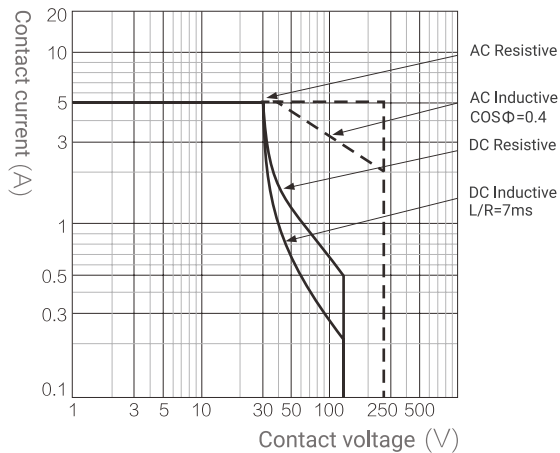

**Electrical endurance-Resistive load**

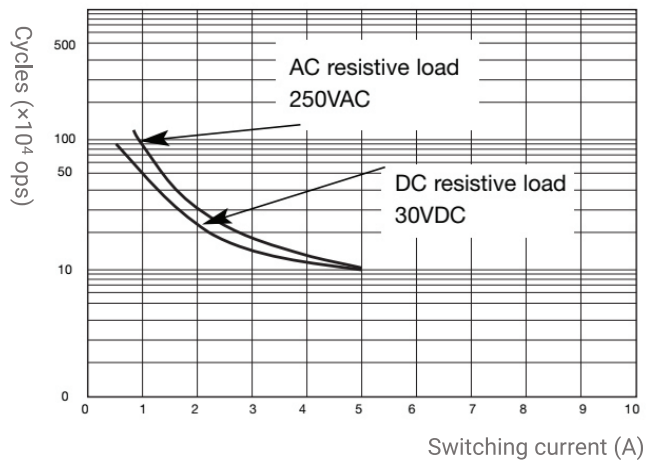

## TS-V TRB

TBLOC's TS-V TRB sockets have the following specifications:

- Compatible with TRB relay series
- Wiring with screw connection methodology
- Two type of contact configuration including:
  - 2 change over contact configuration with 12A rated current contact
  - 4 change over contact configuration with 10A rated current contact
- Plugs with special material and plating to reduce the contact resistance between the relay and the socket
- Insulating material PA6.6 with self-extinguishing properties
- Providing marking accessories with each socket
- Mounting on TH35 DIN rails
- UL and EAC certificates approved
- Compliant with IEC 61810-1 and IEC 61984 standards and CE low voltage directive
- Has accessories such as relay holder and coil protection modules



Tbloc TS-V TRB product selection guide is shown below:

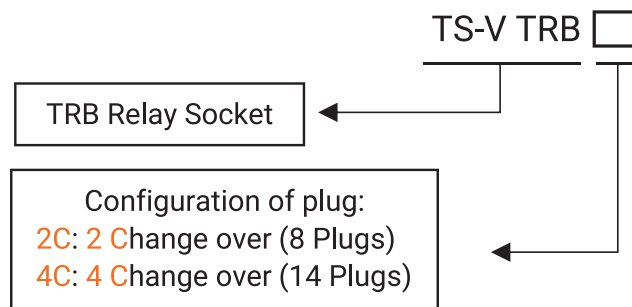



## TS-V TRB



Technical data		TS-V TRB 2C	TS-V TRB 4C
Contact configuration		2 Change-over	4 Change-over
Ordering No.		8036024000	8036024002
Qty.		10	10
Contact rating	Current(A) Voltage(V)	12 300	10 300
Insulation material (Flammability class)		PA66 +GF (V2)	
Socket color		Black	
Contact material		CuNi	
Contact surface		Tin plated	
Terminal type		Screw cage	
Screw material		Steel with 5µm nickel plated	
Screw type		M3	
Operating temperature (°C)		-25 ~ +70	
Protection degree		IP 20	
Mounting		DIN rail mounting	
Connection data			
Rigid solid (mm <sup>2</sup> )		0.5 - 4	
Rigid stranded (mm <sup>2</sup> )		0.5 - 4	
Flexible unprepared (mm <sup>2</sup> )		0.5 - 2.5	
Flexible prepared with ... (mm <sup>2</sup> )	Ferrules without plastic sleeve Ferrules with plastic sleeve	0.5 - 4 0.5 - 2.5	
Stripping length (mm)		8	
Maximum screw torque (N.m)		1	
Weight (g)		49.9 (2C) / 58.7 (4C)	
Dimension			
TS-V TRB 2C		TS-V TRB 4C	
Wiring Diagram			
Accessories			
Description	Type	Order Number	
Plastic holder	CP- TRB	8036330001	
RC Module	RCM (110-230VAC)	8036330042	
Diode module	DM (6-230VDC)	8036330011	

## TS-V TRB Accessories



### Plastic holder

Plastic holder keep the TRB relays firmly on the TS-V TRB sockets. This accessory is useful for environments with vibration.

Type	Ordering No.	Qty.	Material	Dimensions (W/H/L) (mm)
CP-TRB	8036330001	10	PA	26.5/60/22.5



### RC module

RC module consists of a resistor series with a capacitor as a harmonic filter. This module protects 110-230 VAC coil of TRB relay against voltage harmonics.

Type	Ordering No.	Qty.	Material	Dimensions (W/H/L) (mm)
RCM (110-230 VAC)	8036330042	10	PA	11.5/31/12.4



### Diode module

Diode module consists of a diode as a freewheeling diode. This module protects 6-230 VDC coil of TRB relays.

Type	Ordering No.	Qty.	Material	Dimensions (W/H/L) (mm)
DM (6-230 VDC)	8036330011	10	PA	11.5/31/12.4



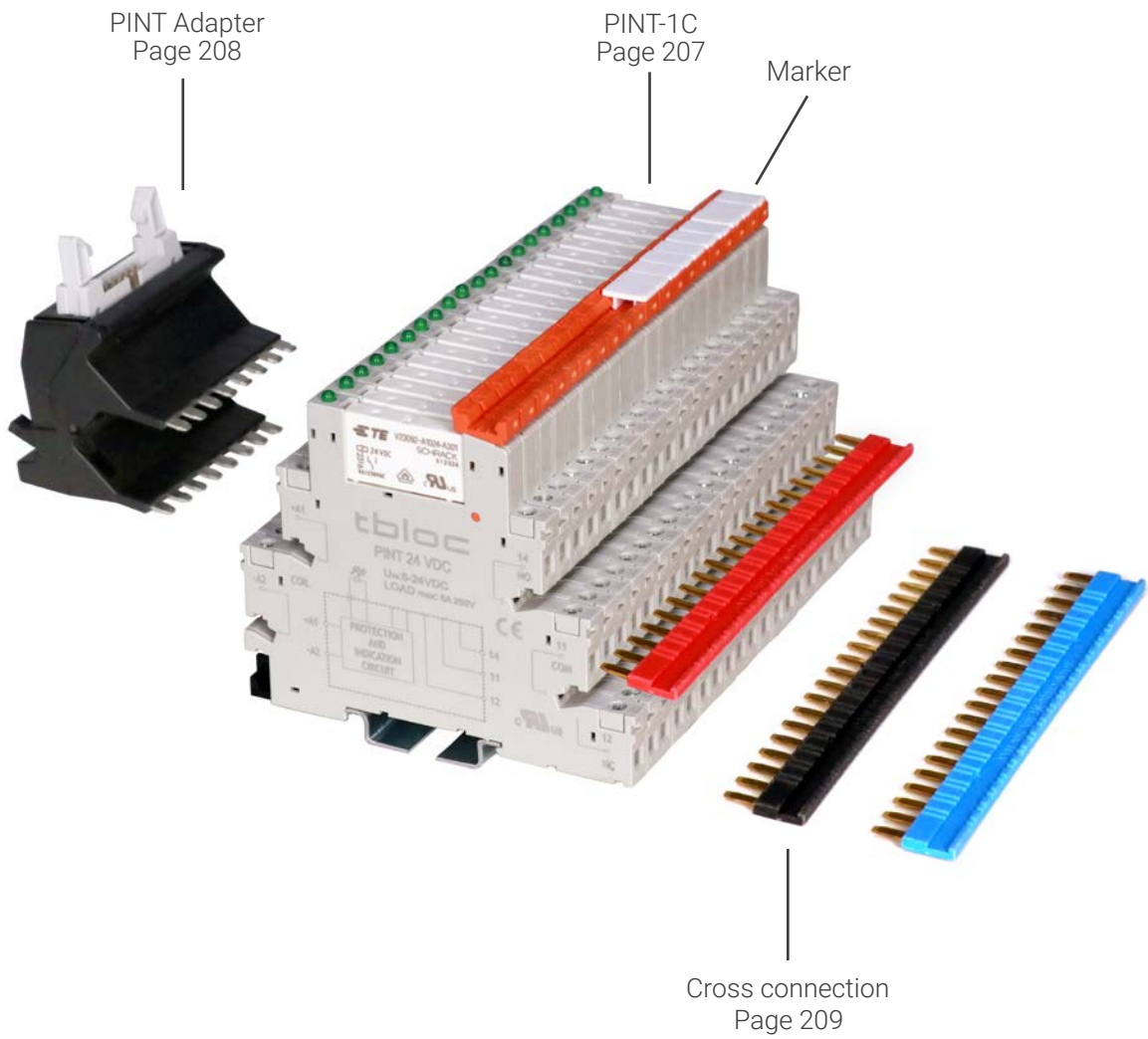

## ■ PINT-R1 series

TBLOC's PINT-R1 relays have the following specifications:

- Contact configuration including:
  - 1 change over contact configuration with 6A switching capacity
- Different levels of coil voltage including:
  - 24 V DC (Suitable for PINT-1C-24 VDC-6A)
  - 60 V DC (Suitable for PINT-1C-220-240 VAC/DC-6A)
- Sensitive coil with a power consumption of 170mW
- Special contact material with high switching power to increase mechanical and electrical life
- Compact structure with a width of 5 mm
- UL and VDE certificates approved
- Compliant with IEC 61810-1 and IEC 61810-7 standards and CE low voltage directive
- Has accessory such as socket

Tbloc PINT-R1 product selection guide is shown below:

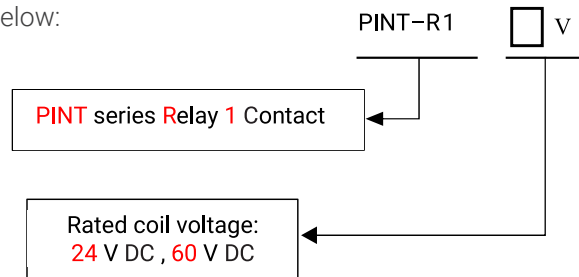

**Dimension(mm):**

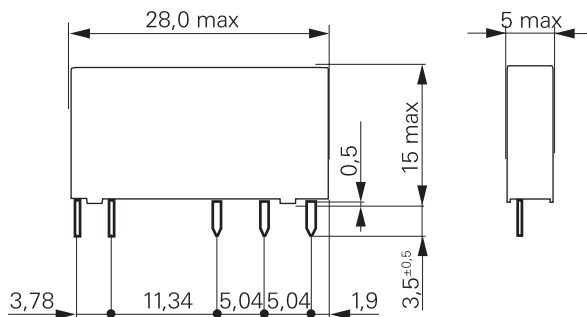

**Wiring diagram:**

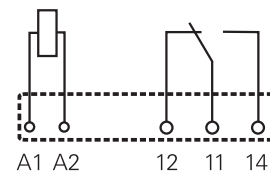



## Technical data

### Coil specification and Ordering code

Type	Rated coil voltage	at +23 °C		Coil resistance(Ω)	Coil consumption	Ordering No.	Qty.
		Pick-up voltage	Drop-out voltage				
PINT-R1 24 V	24 V DC	16.8 VDC	1.2	3390±10%	0.17W	8131241525	20
PINT-R1 60 V	60 V DC	42.0 VDC	3.0	20500 ±15%	0.176W	8131241527	20

### Electrical specification

Contact configuration	1 Change-over
Contact rating	6A, 250VAC/30VDC
UL contact rating	6A, 250VAC/30VDC
Material	AgSnO <sub>2</sub>
Minimum current	100mA@12V
Maximum inrush current	10A (Maximum 4 second, duty factor 10%)
Maximum switching voltage (VAC)	400
Maximum switching power (VA)	1500
Electrical life (Cycles)	>6x10 <sup>4</sup>
Mechanical life (Cycles)	>1x10 <sup>7</sup>

### Insulation

Rated insulation voltage (VAC)	250
Pollution degree	3
Overtoltage category	III
Dielectric strength (1 min, 50/60Hz)	Between coil and contacts(Vrms) 4000
	Between two open contacts(Vrms) 1000
Insulation resistance	>1000 MΩ (at 500.0VDC)

### General data

Operating time (at nominal voltage)	<12ms
Release time (at nominal voltage)	<5ms
Ambient temperature (°C)	-40 ~ +85
Vibration resistance (g)	10
Shock resistance(g)	Functional Destructive
	10 30
Humidity	5%-85% RH non-condensing
Terminals	PCB or Soldering Lugs (Plug-in)
Weight(g)	5

Max DC Breaking Capacity

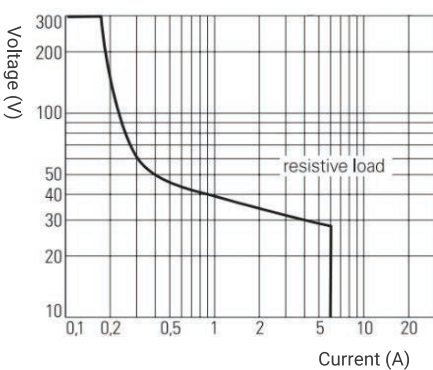

Electrical endurance-Resistive load

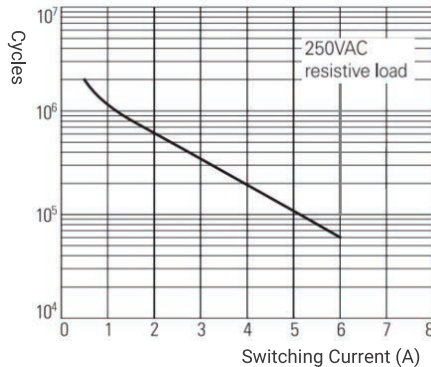

Operating voltage range DC

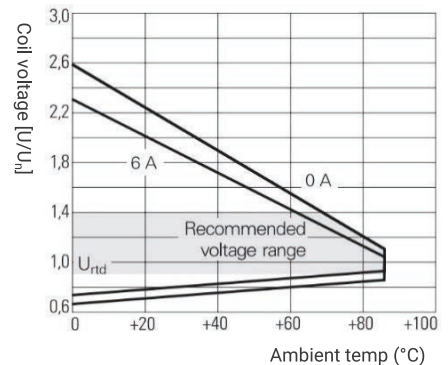

# PINT1-C series

- TBLOC's PINT-1C series modules (relay+socket) have the following specifications:
- Contact configuration including:
  - 1 change over contact configuration with 6A switching capacity
- Different levels of coil voltage including:
  - 24 VDC (with relay PINT-R1 24 V)
  - 220-240 VAC/DC (with relay PINT-R1 60 V)
- Reduced system width due to 6.3 mm module width
- Special relay contact material with high switching power to increase mechanical and electrical life
- Socket's orange lever to remove the relay from the socket
- Socket's green LED coil status indicator
- Socket's plugs with special material and plating to reduce the contact resistance between the relay and the socket
- Insulating material PA6.6 with self-extinguishing properties
- Providing marking tags with each modules
- Mounting on TH35 DIN rails
- UL and EAC certificates approved
- Compliant with IEC 61810-1 and IEC 61810-7 standards and CE low voltage directive
- Has accessories such as replaceable relay, marking tag, cross connections, and adapter

Tbloc PINT1-C product selection guide is shown below:

PINT- 1C -  V  - 6A

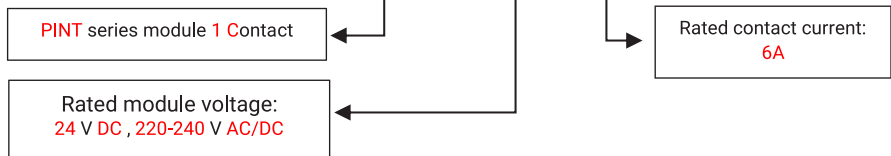

Dimension(mm):

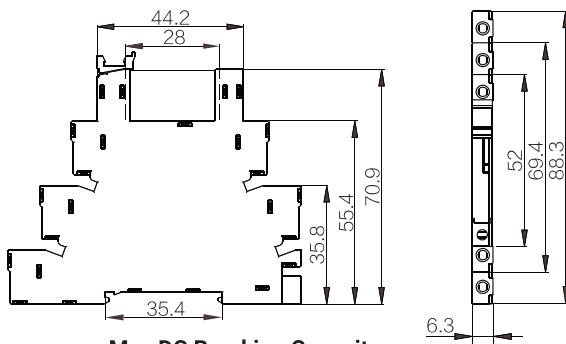

Max DC Breaking Capacity

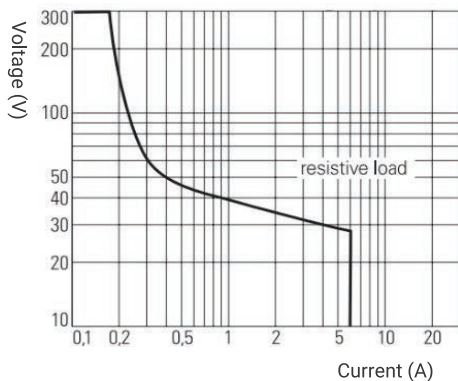

Wiring diagram:

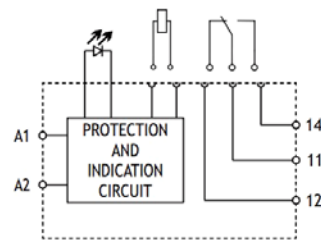

Electrical endurance-Resistive load

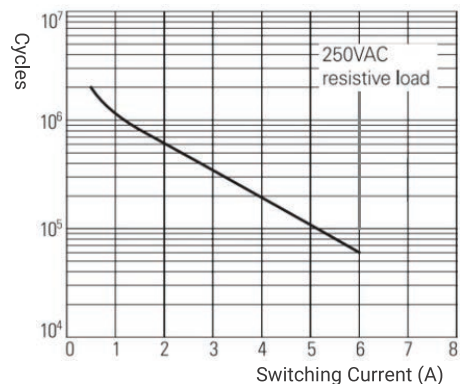



## Technical data

### Coil specification and Ordering code

Type	Rated module voltage	at +23 °C		Relay type	Ordering No.	Qty.
		Pick-up voltage	Drop-out voltage			
PINT-1C 24 V DC-6A	24 VDC	16.8	1.2	PINT-R1 24 V	8031241500	20
PINT-1C 220-240 V AC/DC-6A	220-240 VAC/DC	157 VAC/DC	13 VAC/DC	PINT-R1 60 V	8031241513	20

### Electrical specification

Contact configuration	1 Change-over
Contact rating	6A, 250VAC/30VDC
UL contact rating	6A, 250VAC/30VDC
Operating time (at nominal voltage)	<12ms
Release time (at nominal voltage)	<10ms
Minimum current	100mA@12V
Maximum inrush current	10A (Maximum 4 second, duty factor 10%)
Maximum switching voltage (VAC)	250
Maximum switching power (VA)	1500
Electrical life (Cycles)	> 6x10 <sup>4</sup>
Mechanical life (Cycles)	>1x10 <sup>7</sup>

### Insulation

Rated insulation voltage (VAC)	300	
Pollution degree	2	
Overvoltage category	III	
Dielectric strength (1 min, 50/60Hz)	Between coil and contacts(Vrms)	3000
	Between two open contacts(Vrms)	1000

### General data

Terminal type	Screw cage
Operating temperature (°C)	-40 ~ +70
Terminal protection degree	IP20
Mounting	DIN rail mounting
Socket material (Flammability class)	PA66+GF (V0)
Weight (g)	30.5

### Connection data

Rigid solid (mm <sup>2</sup> )	0.5 - 2.5	
Rigid stranded (mm <sup>2</sup> )	0.5 - 2.5	
Flexible unprepared (mm <sup>2</sup> )	0.5 - 2.5	
Flexible prepared with ... (mm <sup>2</sup> )	Ferrules without plastic sleeve	0.5 - 2.5
	Ferrules with plastic sleeve	0.5 - 2.5
Stripping length (mm)	7	
Maximum screw torque (N.m)	0.8	
Screw type	M3	

### Accessories

Description	Type	Ordering No.
Adapter	PINT Adapter	8031241533
Cross connection	JP PINT-20-Blue	8036331000
	JP PINT-20-Black	8036331001
	JP PINT-20-Red	8036331002

# PINT1-C Accessories



## PINT adapters

It is used to connect control systems (such as PLC) to the PINT-1C series module, which will save wiring and time.

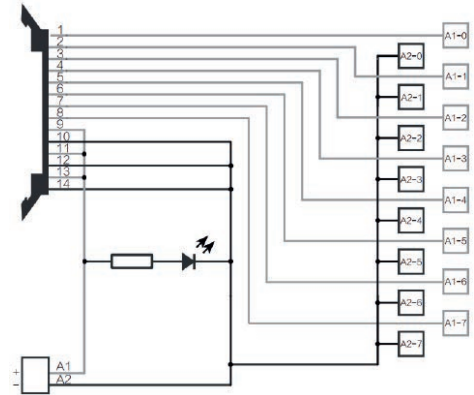

### Ordering code

Type	PINT adapter
Ordering No.	8031241533
Qty.	1

### Technical data

Supply	
Supply voltage (V DC)	24
Operating voltage range (V DC)	19.2-26.4
Status indicator	Green LED
Signals	
Rated voltage (V DC)	24
Maximum voltage (V DC)	30
Rated current (per signal path) (mA)	125
Maximum current (per signal path) (A)	1
Maximum total current for all signals (A)	1
Number of signal paths	8
Connection data (Supply)	
Terminal type	Screw cage
Rigid solid (mm <sup>2</sup> )	0.5-4
Flexible (mm <sup>2</sup> )	0.5-2.5
Stripping length (mm)	9.5
Screw torque (N.m)	0.5
Connection data (Signals)	
Plug type	14 plugs According to IEC60603-13
General data	
Operating temperature (°C)	-40 ~ +70
Humidity	5%-85% RH (non-condensing)
Insulation	
Pollution degree	2
Overvoltage category	III
Impulse withstand voltage (kV)	1.5
Dimension	
Width/Height/Length (mm)	46.9/60/49.6

## Cross Connections

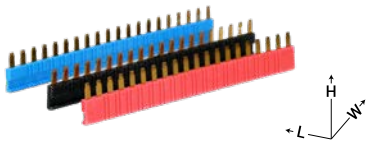

It is a pluggable cross connection used to connect up to twenty of PINT-1C series terminals together. It is available with plastic insulation, red, black and blue colors.

### Ordering code

Type	Ordering No.	Qty.	Insulation color	Dimensions (W/H/L) (mm)
JP-PINT-20-Blue	8036331000	5	Blue	3/17.4/122.2
JP-PINT-20-Black	8036331001	5	Black	
JP-PINT-20-Red	8036331002	5	Red	



**RAAD**  <sup>®</sup> Electrical Connection for  
Technological Components  
*Confidence in Connection*

# Distribution Terminal Blocks



The use of tbloc company's distribution terminal blocks instead of copper busbars in electrical panels leads to a reduction in the cost and time of panel building and ease in the distribution of electricity in electrical panels. tbloc's distribution terminal blocks include the following three product categories:

1- SDB is a single-pole distribution terminal block with a rated current from 80A to 500A. These products can be installed on 35 mm rails and flat plates, and also the variety in the number of inputs and outputs of these products leads to facilitating the distribution of electricity in the electrical panel.

2- TDB is a two-pole distribution terminal block used for wiring two-phase or one-phase with neutral systems. The presence of a transparent partition plate between each pole leads to a safe connection in these terminals. Also, the transparent cover with the ability to separate from the terminal body creates a better situation in the wiring of the product.

This product group is offered to the market with a rated current of 80A, 100A and 125A. Also, these products can be installed on 35mm rails as well as flat surfaces.

3- FDB is a four-pole distribution terminal block used for wiring three-phase with neutral systems. The presence of a transparent partition plate between each pole leads to a safe connection in these terminals. The transparent cover with the ability to separate from the terminal body creates a better situation in the wiring of these products.

The rated current of these products is 80A, 100A and 125A.

Also, these products can be installed on 35mm rails as well as flat surfaces.



**SDB 80A**

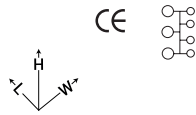

**SDB 125A**

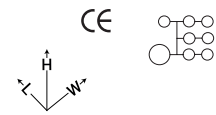

Technical data	SDB 80A		SDB 125A			
	Voltage(V)	Current(A)	Voltage(V)	Current(A)		
IEC 60947-7-1 UL 1059	1000 600	80 85	1000 600	125 150		
<b>IEC 60947-7-1 rated data</b>						
Impulse voltage (kV)	12		12			
Pollution degree/Voltage category/Material group	3/III/I		3/III/I			
I <sub>cw</sub> (kA)	3		4.2			
I <sub>pk</sub> (kA)	22		30			
<b>Description</b>	<b>Type</b>	<b>Ordering No.</b>	<b>Qty.</b>	<b>Type</b>	<b>Ordering No.</b>	<b>Qty.</b>
Terminal block, for mounting on TH 35-7.5, 15	SDB 80A	8037000100	1	SDB 125A	8037000110	1
<b>Connection data</b>						
<b>Input</b>		<b>Line</b>		<b>Line</b>		
Connection Points		1		1		
Diameter (mm)		6.8		10		
Connection capacity	(mm <sup>2</sup> )	6 - 16		10 - 35		
	(AWG)	10 - 6		8 - 2		
Tightening torque (N·m)		3.5		8.5		
Stripping length (mm)		17		15.2		
<b>Output</b>		<b>Load 1</b>		<b>Load 1</b>		
Connection Points		4		1		
Diameter (mm)		4.5		6.8		
Connection capacity	(mm <sup>2</sup> )	2.5 - 6		6 - 16		
	(AWG)	14 - 6		10 - 6		
Tightening torque (N·m)		1.2		3.5		
Stripping length (mm)		10.2		14.7		
<b>Output</b>		<b>Load 2</b>		<b>Load 2</b>		
Connection Points		2		6		
Diameter (mm)		6.8		6.8		
Connection capacity	(mm <sup>2</sup> )	2.5 - 16		2.5 - 16		
	(AWG)	14 - 6		14 - 6		
Tightening torque (N·m)		3.5		3.5		
Stripping length (mm)		17				
Color	Body	Gray		Gray		
	Cover	Dark gray		Dark gray		
<b>Dimensions (mm)</b>		<b>W / L / H</b>		<b>W / L / H</b>		
Width/Length/Height		27/66/46		29/77/46		
<b>Insulation material</b>						
Body		PA 6.6 / V-0		PA 6.6 / V-0		
Cover		PC		PC		



### SDB 160A

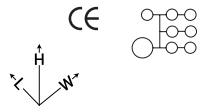

### SDB 250A

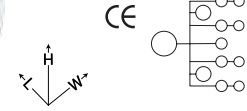

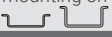
Technical data	SDB 160A			SDB 250A		
	Voltage(V)	Current(A)		Voltage(V)	Current(A)	
IEC 60947-7-1 UL 1059	1000 600	160 200		1000 600	250 255	
<b>IEC 60947-7-1 rated data</b>						
Impulse voltage (kV)	12			12		
Pollution degree/Voltage category/Material group	3/III/I			3/III/I		
$I_{cw}$ (kA)	11.8			24.5		
$I_{pk}$ (kA)	30			51		
<b>Description</b>						
Terminal block, for mounting on TH 35-7.5, 15 	Type	Ordering No.	Qty.	Type	Ordering No.	Qty.
	SDB 160A	8037000120	1	SDB 250A	8037000130	1
<b>Connection data</b>						
<b>Input</b>		<b>Line</b>		<b>Line</b>		
Connection Points		1		1		
Diameter (mm)		12.3		15		
Connection capacity	(mm <sup>2</sup> )	10 – 70		35 – 120		
	(AWG)	8 - 00		2 – 250 kcmil		
Tightening torque (N·m)		8.5		19		
Stripping length (mm)		15.2		26.4		
<b>Output</b>		<b>Load 1</b>		<b>Load 1</b>		
Connection Points		1		2		
Diameter (mm)		6.8		9		
Connection capacity	(mm <sup>2</sup> )	6 – 16		6 – 35		
	(AWG)	10 – 6		10 – 2		
Tightening torque (N·m)		3.5		4.4		
Stripping length (mm)		14.7		15.9		
<b>Output</b>		<b>Load 2</b>		<b>Load 2</b>		
Connection Points		6		4		
Diameter (mm)		6.8		6.1		
Connection capacity	(mm <sup>2</sup> )	2.5 – 16		2.5 – 10		
	(AWG)	14 – 6		14 – 8		
Tightening torque (N·m)		3.5		2.7		
Stripping length (mm)				9.8		
<b>Output</b>				<b>Load 3</b>		
Connection Points				5		
Diameter (mm)				6.8		
Connection capacity	(mm <sup>2</sup> )			2.5 – 16		
	(AWG)			14 - 8		
Tightening torque (N·m)				2.7		
Stripping length (mm)				10.2		
Color	Body	Gray		Gray		
	Cover	Dark gray		Dark gray		
<b>Dimensions (mm)</b>		<b>W / L / H</b>		<b>W / L / H</b>		
Width/Length/Height		29/77/46		46/96/50		
<b>Insulation material</b>						
Body		PA 6.6 / V-0		PA 6.6 / V-0		
Cover		PC		PC		



■ SDB 400A

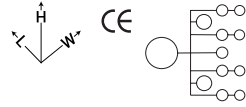

■ SDB 500A

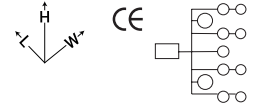

Technical data	SDB 400A		SDB 500A	
	Voltage(V)	Current(A)	Voltage(V)	Current(A)
IEC 60947-7-1	1000	400	1000	500
UL 1059	600	335	600	335
<b>IEC 60947-7-1 rated data</b>				
Impulse voltage (kV)	12		12	
Pollution degree/Voltage category/Material group	3 / III / I		3 / III / I	
I <sub>cw</sub> (kA)	24.5		24.5	
I <sub>pk</sub> (kA)	51		51	

Description	Type	Ordering No.	Qty.	Type	Ordering No.	Qty.
Terminal block, for mounting on TH 35-7.5, 15	SDB 400A	8037000140	1	SDB 500A	8037000150	1
<b>Connection data</b>						
<b>Input</b>		<b>Line</b>		<b>Line</b>		
Connection Points		1		1		
Diameter (mm)		19		-		
Connection capacity	(mm <sup>2</sup> )	95 – 185		2x20x1 – 8x24x1		
	(AWG)	000 – 350 kcmil		-		
Tightening torque (N·m)		25		13.5		
Stripping length (mm)		26.4		28		
<b>Output</b>		<b>Load 1</b>		<b>Load 1</b>		
Connection Points		2		2		
Diameter (mm)		9		9		
Connection capacity	(mm <sup>2</sup> )	6 – 35		6 – 35		
	(AWG)	10 – 2		10 - 2		
Tightening torque (N·m)		4.4		4.4		
Stripping length (mm)		15.9		15.9		
<b>Output</b>		<b>Load 2</b>		<b>Load 2</b>		
Connection Points		4		4		
Diameter (mm)		6.1		6.1		
Connection capacity	(mm <sup>2</sup> )	2.5 – 10		2.5 – 10		
	(AWG)	14 – 8		14 – 8		
Tightening torque (N·m)		2.7		2.7		
Stripping length (mm)		9.8		9.8		
<b>Output</b>		<b>Load 3</b>		<b>Load 3</b>		
Connection Points		5		5		
Diameter (mm)		6.8		6.8		
Connection capacity	(mm <sup>2</sup> )	2.5 – 16		2.5 – 16		
	(AWG)	14 - 6		14 – 6		
Tightening torque (N·m)		2.7		2.7		
Stripping length (mm)		10.2		10.2		
Color	Body	Gray		Gray		
	Cover	Dark gray		Dark gray		
<b>Dimensions (mm)</b>		<b>W / L / H</b>		<b>W / L / H</b>		
Width/Length/Height		46/96/50		46/96/50		
<b>Insulation material</b>						
Body		PA 6.6 / V-0		PA 6.6 / V-0		
Cover		PC		PC		



**TDB 2x8-80A**

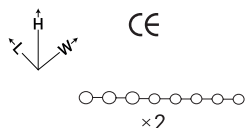

**TDB 2x18-80A**

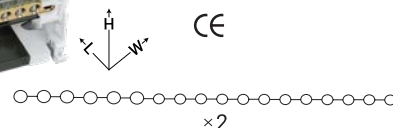

Technical data	TDB 2x8-80A		TDB 2x18-80A	
	Voltage(V)	Current(A)	Voltage(V)	Current(A)
IEC 60947-7-1	500	80	500	80
<b>IEC 60947-7-1 rated data</b>				
Impulse voltage (kV)	4		4	
Pollution degree/Voltage category/Material group	3 / III / I		3 / III / I	
I <sub>cw</sub> (kA)	4.5		4.5	
I <sub>pk</sub> (kA)	20		20	

Description	Type	Ordering No.	Qty.	Type	Ordering No.	Qty.
Terminal block, for mounting on TH 35-7.5, 15	TDB 2x8-80A	8037000210	1	TDB 2x18-80A	8037000211	1
<b>Connection data</b>						
<b>Input</b>		<b>Line</b>		<b>Line</b>		
Connection Points		3		6		
Diameter (mm)		5.5		5.5		
Connection capacity	Rigid (mm <sup>2</sup> )	2.5 – 16		2.5 – 16		
	Flexible (mm <sup>2</sup> )*	1.5 – 10		1.5 – 10		
	(AWG)	14 – 6		14 – 6		
Tightening torque (N·m)		2		2		
Stripping length (mm)		8 – 10		8 – 10		
<b>Output</b>		<b>Load</b>		<b>Load</b>		
Connection Points		5		12		
Diameter (mm)		4.5		4.5		
Connection capacity	Rigid (mm <sup>2</sup> )	1.5 – 10		1.5 – 10		
	Flexible (mm <sup>2</sup> )*	0.75 - 6		0.75 - 6		
	(AWG)	16 – 8		16 – 8		
Tightening torque (N·m)		1.2		1.2		
Stripping length (mm)		8 – 10		8 - 10		
Color	Body	Gray		Gray		
	Cover	Dark gray		Dark gray		
<b>Dimensions (mm)</b>		<b>W / L / H</b>		<b>W / L / H</b>		
Width/Length/Height		64/50/50		130/50/50		
<b>Insulation material</b>						
Body		PA 6.6 / V-0		PA 6.6 / V-0		
Cover		PC		PC		

\*Prepare this kind of cable with ferrule.



■ TDB 2x7-100A

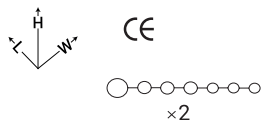

■ TDB 2x11-100A

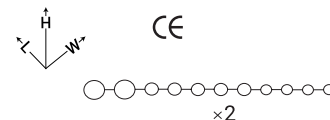

Technical data	TDB 2x7-100A		TDB 2x11-100A	
	Voltage(V)	Current(A)	Voltage(V)	Current(A)
IEC 60947-7-1	500	100	500	100
<b>IEC 60947-7-1 rated data</b>				
Impulse voltage (kV)	4		4	
Pollution degree/Voltage category/Material group	3 / III / I		3 / III / I	
I <sub>cw</sub> (kA)	4.5		4.5	
I <sub>pk</sub> (kA)	20		20	

Description	Type	Ordering No.	Qty.	Type	Ordering No.	Qty.
Terminal block, for mounting on TH 35-7.5, 15	TDB 2x7-100A	8037000220	1	TDB 2x11-100A	8037000221	1
<b>Connection data</b>						
<b>Input</b>		<b>Line</b>		<b>Line</b>		
Connection Points		1		2		
Diameter (mm)		8.5		8.5		
Connection capacity	Rigid (mm <sup>2</sup> )	10 – 25		10 – 25		
	Flexible (mm <sup>2</sup> )*	10 – 25		10 – 25		
	(AWG)	8 – 4		8 – 4		
Tightening torque (N·m)		2 – 3		2 – 3		
Stripping length (mm)		8 – 10		8 – 10		
<b>Output</b>		<b>Load 1</b>		<b>Load 1</b>		
Connection Points		3		4		
Diameter (mm)		4.5		4.5		
Connection capacity	Rigid (mm <sup>2</sup> )	1.5 – 4		1.5 – 4		
	Flexible (mm <sup>2</sup> )*	0.75 – 4		0.75 – 4		
	(AWG)	16 – 12		16 – 12		
Tightening torque (N·m)		1.2 – 1.5		1.2 – 1.5		
Stripping length (mm)		8 – 10		8 – 10		
<b>Output</b>		<b>Load 2</b>		<b>Load 2</b>		
Connection Points		3		5		
Diameter (mm)		5.5		5.5		
Connection capacity	Rigid (mm <sup>2</sup> )	2.5 – 6		2.5 – 6		
	Flexible (mm <sup>2</sup> )*	1.5 – 6		1.5 – 6		
	(AWG)	14 – 10		14 – 10		
Tightening torque (N·m)		2 – 3		2 – 3		
Stripping length (mm)		8 – 10		8 – 10		
Color	Body	Gray		Gray		
	Cover	Dark gray		Dark gray		
<b>Dimensions (mm)</b>		<b>W / L / H</b>		<b>W / L / H</b>		
Width/Length/Height		64/50/50		100/50/50		
<b>Insulation material</b>						
Body		PA 6.6 / V-0		PA 6.6 / V-0		
Cover		PC		PC		

\*Prepare this kind of cable with ferrule.



■ TDB 2x7-125A

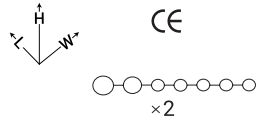

■ TDB 2x11-125A

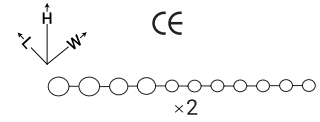

Technical data	TDB 2x7-125A		TDB 2x11-125A	
	Voltage(V)	Current(A)	Voltage(V)	Current(A)
IEC 60947-7-1	500	125	500	125
<b>IEC 60947-7-1 rated data</b>				
Impulse voltage (kV)	4		4	
Pollution degree/Voltage category/Material group	3 / III / I		3 / III / I	
I <sub>cw</sub> (kA)	4.5		4.5	
I <sub>pk</sub> (kA)	20		20	

Description	Type	Ordering No.	Qty.	Type	Ordering No.	Qty.
Terminal block, for mounting on TH 35-7.5, 15	TDB 2x7-125A	8037000230	1	TDB 2x11-125A	8037000231	1
<b>Connection data</b>						
<b>Input</b>		<b>Line</b>		<b>Line</b>		
Connection Points		1		2		
Diameter (mm)		8.5		8.5		
Connection capacity	Rigid (mm <sup>2</sup> )	10 – 35		10 – 35		
	Flexible (mm <sup>2</sup> )*	10 – 25		10 – 25		
	(AWG)	8 – 2		8 – 2		
Tightening torque (N·m)		2 – 3		2 – 3		
Stripping length (mm)		8 – 10		8 – 10		
<b>Output</b>		<b>Load 1</b>		<b>Load 1</b>		
Connection Points		1		2		
Diameter (mm)		7.5		7.5		
Connection capacity	Rigid (mm <sup>2</sup> )	10 – 25		2.5 – 6		
	Flexible (mm <sup>2</sup> )*	6 – 16		1.5 – 6		
	(AWG)	8 – 4		8 – 4		
Tightening torque (N·m)		2 – 3		2 – 3		
Stripping length (mm)		8 – 10		8 – 10		
<b>Output</b>		<b>Load 2</b>		<b>Load 2</b>		
Connection Points		5		7		
Diameter (mm)		5.3		5.3		
Connection capacity	Rigid (mm <sup>2</sup> )	2.5 – 6		2.5 – 6		
	Flexible (mm <sup>2</sup> )*	1.5 – 6		1.5 – 6		
	(AWG)	14 – 10		14 – 10		
Tightening torque (N·m)		2 – 3		2 – 3		
Stripping length (mm)		8 – 10		8 – 10		
Color	Body	Gray		Gray		
	Cover	Dark gray		Dark gray		
<b>Dimensions (mm)</b>		<b>W / L / H</b>		<b>W / L / H</b>		
Width/Length/Height		64/50/50		100/50/50		
<b>Insulation material</b>						
Body		PA 6.6 / V-0		PA 6.6 / V-0		
Cover		PC		PC		

\*Prepare this kind of cable with ferrule.



## TDB 2x15-125A



CE

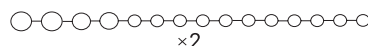

Technical data	TDB 2x15-125A	
	Voltage(V)	Current(A)
IEC 60947-7-1	500	125
<b>IEC 60947-7-1 rated data</b>		
Impulse voltage (kV)	4	
Pollution degree/Voltage category/Material group	3 / III / I	
I <sub>cw</sub> (kA)	4.5	
I <sub>pk</sub> (kA)	20	

Description	Type	Ordering No.	Qty.
Terminal block, for mounting on TH 35-7.5, 15	TDB 2x15-125A	8037000232	1
<b>Connection data</b>			
<b>Input</b>		<b>Line</b>	
Connection Points		2	
Diameter (mm)		8.5	
Connection capacity	Rigid (mm <sup>2</sup> )	10 – 35	
	Flexible (mm <sup>2</sup> )*	10 – 25	
	(AWG)	8 – 2	
Tightening torque (N·m)		2 – 3	
Stripping length (mm)		8 – 10	
<b>Output</b>		<b>Load 1</b>	
Connection Points		2	
Diameter (mm)		7.5	
Connection capacity	Rigid (mm <sup>2</sup> )	10 – 25	
	Flexible (mm <sup>2</sup> )*	6 – 16	
	(AWG)	8 – 6	
Tightening torque (N·m)		2 – 3	
Stripping length (mm)		8 – 10	
<b>Output</b>		<b>Load 2</b>	
Connection Points		11	
Diameter (mm)		5.3	
Connection capacity	Rigid (mm <sup>2</sup> )	2.5 – 6	
	Flexible (mm <sup>2</sup> )*	15 – 6	
	(AWG)	14 – 10	
Tightening torque (N·m)		2 – 3	
Stripping length (mm)		8 – 10	
Color	Body	Gray	
	Cover	Dark gray	
<b>Dimensions(mm)</b>		<b>W / L / H</b>	
Width/Length/Height		130/50/50	
<b>Insulation material</b>			
Body		PA 6.6 / V-0	
Cover		PC	

\*Prepare this kind of cable with ferrule.



**FDB 4x8-80A**



CE

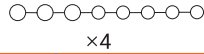

**FDB 4x18-80A**



CE

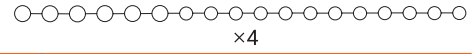

Technical data	FDB 4x8-80A		FDB 4x18-80A	
	Voltage(V)	Current(A)	Voltage(V)	Current(A)
IEC 60947-7-1	500	80	500	80
<b>IEC 60947-7-1 rated data</b>				
Impulse voltage (kV)	4		4	
Pollution degree/Voltage category/Material group	3 / III / I		3 / III / I	
I <sub>cw</sub> (kA)	4.5		4.5	
I <sub>pk</sub> (kA)	20		20	

Description	Type	Ordering No.	Qty.	Type	Ordering No.	Qty.
Terminal block, for mounting on TH 35-7.5, 15	FDB 4x8-80A	8037000310	1	FDB 4x18-80A	8037000312	1
<b>Connection data</b>						
<b>Input</b>		<b>Line</b>		<b>Line</b>		
Connection Points		3		6		
Diameter (mm)		5.5		5.5		
Connection capacity	Rigid (mm <sup>2</sup> )	2.5 – 16		2.5 – 16		
	Flexible (mm <sup>2</sup> )*	1.5 – 10		1.5 – 10		
	(AWG)	14 – 6		14 – 6		
Tightening torque (N·m)		2		2		
Stripping length (mm)		8 – 10		8 – 10		
<b>Output</b>		<b>Load</b>		<b>Load</b>		
Connection Points		5		12		
Diameter (mm)		4.5		4.5		
Connection capacity	Rigid (mm <sup>2</sup> )	1.5 – 10		1.5 – 10		
	Flexible (mm <sup>2</sup> )*	0.75 – 6		16 – 8		
	(AWG)	16 – 8		14 – 6		
Tightening torque (N·m)		1.2		1.2		
Stripping length (mm)		8 – 10		8 - 10		
Color	Body	Gray		Gray		
	Cover	Dark gray		Dark gray		
<b>Dimensions (mm)</b>		<b>W / L / H</b>		<b>W / L / H</b>		
Width/Length/Height		64/90/50		130/90/50		
<b>Insulation material</b>						
Body		PA 6.6 / V-0		PA 6.6 / V-0		
Cover		PC		PC		

\*Prepare this kind of cable with ferrule.



■ FDB 4x7-100A

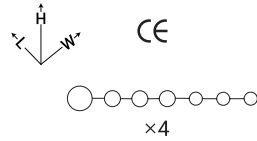

■ FDB 4x11-100A

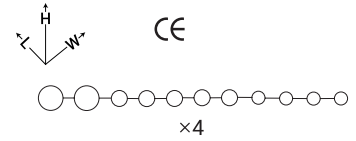

Technical data	FDB 4x7-100A		FDB 4x11-100A	
	Voltage(V)	Current(A)	Voltage(V)	Current(A)
IEC 60947-7-1	500	100	500	100
<b>IEC 60947-7-1 rated data</b>				
Impulse voltage (kV)	4		4	
Pollution degree/Voltage category/Material group	3 / III / I		3 / III / I	
I <sub>cw</sub> (kA)	4.5		4.5	
I <sub>pk</sub> (kA)	20		20	

Description	Type	Ordering No.	Qty.	Type	Ordering No.	Qty.
Terminal block, for mounting on TH 35-7.5, 15	TDB 4x7-100A	8037000320	1	TDB 4x11-100A	8037000321	1
<b>Connection data</b>						
<b>Input</b>		<b>Line</b>		<b>Line</b>		
Connection Points		1		2		
Diameter (mm)		8.5		8.5		
Connection capacity	Rigid (mm <sup>2</sup> )	10 – 25		10 – 25		
	Flexible (mm <sup>2</sup> )*	10 – 25		10 – 25		
	(AWG)	8 – 4		8 – 4		
Tightening torque (N·m)		2 – 3		2 – 3		
Stripping length (mm)		8 – 10		8 – 10		
<b>Output</b>		<b>Load 1</b>		<b>Load 1</b>		
Connection Points		3		4		
Diameter (mm)		4.5		4.5		
Connection capacity	Rigid (mm <sup>2</sup> )	1.5 – 4		1.5 – 4		
	Flexible (mm <sup>2</sup> )*	0.75 – 4		0.75 – 4		
	(AWG)	16 – 12		16 – 13		
Tightening torque (N·m)		1.2 – 1.5		1.2 – 1.5		
Stripping length (mm)		8 – 10		8 – 10		
<b>Output</b>		<b>Load 2</b>		<b>Load 2</b>		
Connection Points		3		5		
Diameter (mm)		5.5		5.5		
Connection capacity	Rigid (mm <sup>2</sup> )	2.5 – 6		2.5 – 6		
	Flexible (mm <sup>2</sup> )*	1.5 – 6		1.5 – 6		
	(AWG)	14 – 10		14 – 10		
Tightening torque (N·m)		2 – 3		2 – 3		
Stripping length (mm)		8 – 10		8 – 10		
Color	Body	Gray		Gray		
	Cover	Dark gray		Dark gray		
<b>Dimensions (mm)</b>		<b>W / L / H</b>		<b>W / L / H</b>		
Width/Length/Height		64/90/50		100/90/50		
<b>Insulation material</b>						
Body		PA 6.6 / V-0		PA 6.6 / V-0		
Cover		PC		PC		

\*Prepare this kind of cable with ferrule.



**FDB 4x7-125A**

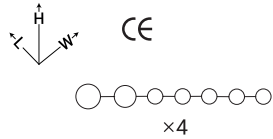

**FDB 4x11-125A**

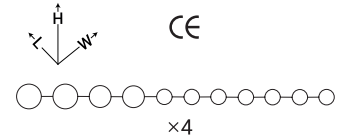

Technical data	FDB 4x7-125A		FDB 4x11-125A	
	Voltage(V)	Current(A)	Voltage(V)	Current(A)
IEC 60947-7-1	500	125	500	125
<b>IEC 60947-7-1 rated data</b>				
Impulse voltage (kV)	4		4	
Pollution degree/Voltage category/Material group	3 / III / I		3 / III / I	
I <sub>cw</sub> (kA)	4.5		4.5	
I <sub>pk</sub> (kA)	20		20	

Description	Type	Ordering No.	Qty.	Type	Ordering No.	Qty.
Terminal block, for mounting on TH 35-7.5, 15	FDB 4x7-125A	8037000330	1	FDB 4x11-125A	8037000331	1
<b>Connection data</b>						
<b>Input</b>		<b>Line</b>		<b>Line</b>		
Connection Points		1		2		
Diameter (mm)		8.5		8.5		
Connection capacity	Rigid (mm <sup>2</sup> )	10 – 35		10 – 35		
	Flexible (mm <sup>2</sup> )*	10 – 25		10 – 25		
	(AWG)	8 – 2		8 – 2		
Tightening torque (N·m)		2 – 3		2 – 3		
Stripping length (mm)		8 – 10		8 – 10		
<b>Output</b>		<b>Load 1</b>		<b>Load 1</b>		
Connection Points		1		2		
Diameter (mm)		7.5		7.5		
Connection capacity	Rigid (mm <sup>2</sup> )	10 – 25		10 – 25		
	Flexible (mm <sup>2</sup> )*	6 – 16		6 – 16		
	(AWG)	8 – 4		8 – 4		
Tightening torque (N·m)		2 – 3		2 – 3		
Stripping length (mm)		8 – 10		8 – 10		
<b>Output</b>		<b>Load 2</b>		<b>Load 2</b>		
Connection Points		5		7		
Diameter (mm)		5.3		5.3		
Connection capacity	Rigid (mm <sup>2</sup> )	2.5 – 6		2.5 – 6		
	Flexible (mm <sup>2</sup> )*	1.5 – 6		1.5 – 6		
	(AWG)	14 – 10		14 – 10		
Tightening torque (N·m)		2 – 3		2 – 3		
Stripping length (mm)		8 – 10		8 – 10		
Color	Body	Gray		Gray		
	Cover	Dark gray		Dark gray		
<b>Dimensions (mm)</b>		<b>W / L / H</b>		<b>W / L / H</b>		
Width/Length/Height		64/90/50		100/90/50		
<b>Insulation material</b>						
Body		PA 6.6 / V-0		PA 6.6 / V-0		
Cover		PC		PC		

\*Prepare this kind of cable with ferrule.



■ FDB 4x15-125A

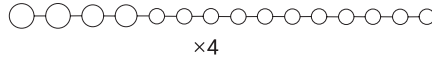
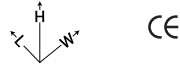

■ FDB 4x12-160A

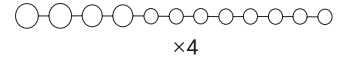
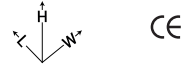

Technical data	FDB 4x15-125A			FDB 4x12-160A		
	Voltage(V)	Current(A)		Voltage(V)	Current(A)	
IEC 60947-7-1	500	125		690	160	
<b>IEC 60947-7-1 rated data</b>						
Impulse voltage (kV)	4			4		
Pollution degree/Voltage category/Material group	3 / III / I			3 / III / I		
I <sub>cw</sub> (kA)	4.5			8.2		
I <sub>pk</sub> (kA)	20			35		
<b>Description</b>	<b>Type</b>	<b>Ordering No.</b>	<b>Qty.</b>	<b>Type</b>	<b>Ordering No.</b>	<b>Qty.</b>
Terminal block, for mounting on TH 35-7.5, 15	FDB 4x15-125A	8037000332	1	FDB 4x12-160A	8037000350	1
<b>Connection data</b>						
<b>Input</b>		<b>Line</b>		<b>Line</b>		
Connection Points		2		1		
Diameter (mm)		8.5		12		
Connection capacity	Rigid (mm <sup>2</sup> )	10 - 35		10 - 50		
	Flexible (mm <sup>2</sup> )*	10 - 25		10 - 50		
	(AWG)	8 - 2		8 - 0		
Tightening torque (N·m)		2 - 3		8 - 10		
Stripping length (mm)		8 - 10		17 - 19		
<b>Output</b>		<b>Load 1</b>		<b>Load 1</b>		
Connection Points		2		3		
Diameter (mm)		7.5		8.5		
Connection capacity	Rigid (mm <sup>2</sup> )	10 - 25		10 - 35		
	Flexible (mm <sup>2</sup> )*	6 - 16		10 - 25		
	(AWG)	8 - 4		8 - 2		
Tightening torque (N·m)		2 - 3		2 - 3		
Stripping length (mm)		8 - 10		10 - 12		
<b>Output</b>		<b>Load 2</b>		<b>Load 2</b>		
Connection Points		11		7		
Diameter (mm)		5.3		7.2		
Connection capacity	Rigid (mm <sup>2</sup> )	2.5 - 6		2.5 - 16		
	Flexible (mm <sup>2</sup> )*	1.5 - 6		1.5 - 16		
	(AWG)	14 - 10		14 - 6		
Tightening torque (N·m)		2 - 3		2 - 3		
Stripping length (mm)		8 - 10		10 - 12		
<b>Output</b>				<b>Load 3</b>		
Connection Points				1		
Diameter (mm)				5.5		
Connection capacity	Rigid (mm <sup>2</sup> )			2.5 - 6		
	Flexible (mm <sup>2</sup> )*			1.5 - 6		
	(AWG)			14 - 10		
Tightening torque (N·m)				2 - 3		
Stripping length (mm)				10 - 12		
Color	Body	Gray		Gray		
	Cover	Dark gray		Dark gray		
<b>Dimensions (mm)</b>		<b>W / L / H</b>		<b>W / L / H</b>		
Width/Length/Height		130/90/50		175/90/50		
<b>Insulation material</b>						
Body		PA 6.6 / V-0		PA 6.6 / V-0		
Cover		PC		PC		

\*Prepare this kind of cable with ferrule.





**RAAD**  <sup>®</sup> Electrical Connection for  
Technological Components  
*Confidence in Connection*

# Certificates

- Achieving a uniform quality in mass production is impossible unless through establishment of quality management system. Having the certificate of quality management system in accordance with ISO 9001:2015 issued by authorized and well-known standard institutions, RAAD Manufacturing Company is seeking to assure its customers for the existence of such system.
- Furthermore, RAAD products' quality is proven by outstanding institutions, being well-known in electric field all around the world, offered various types of certificates, in accordance with 2006/95/EC LV Directive.
- Both, the certificates of products' quality and quality management system indicate reliable products, manufactured by the company. The development plan to gain other certificates on products' quality and quality management system is still alive and continuing.



## Material

RAAD products use parts and materials that conform to standards in the electrical industry and are subject to quality control system.

### Metals

All metal parts in RAAD products are electro-plated using the latest state-of-the-art engineering methods.

The surface protection conforms to technical standards. Steel parts at the beginning are zinc-plated and then a white chromate layer coats over the zinc, providing the best possible passivation.

Copper and brass parts are tin-plated and Nickel plated accordingly. Tin plating provides excellent protection against corrosion and has good electrical conduction.

### Steel

This is the most commonly used grade of spring steel strip in our push-in clamps. The tensile strength can reach up to 2200 MPa. The material offers the user a unique combination of tensile strength/spring properties in conjunction with excellent formability. These strips are processed into clamp parts even at comparatively high tensile strengths and are analytically compliant to the American material standard AISI 301 (US S30100). The temperature resistance depending on the type of load is up to 250 °C.

### Insulating Materials

RAAD terminal blocks use thermoplastics for insulating materials.

Thermoplastics are processed using economical and environmentally healthy injection molding processes, and have good recycling properties and can be reused. Polyamide is a thermoplastic, used in the insulation body of RAAD products. This modern semi-crystalline material has excellent electrical, mechanical, chemical, and other characteristics even at 100°C for continuous operating.

The short-time peak temperatures are permissible up to about 200°C and the melting point is around 260°C.

Polyamide absorbs moisture from its surroundings, on average 2.8 %. This makes the PA more flexible and resistant to breakage, even at -40°C. Today PA is approved to be used by the approval authorities such as CSA, NEMKO, KEMA, PTB, SEV, UL, VDE, etc.

Properties	Standard	Unit	PA
Max. application temperature (RTI)	IEC60216-1	°C,<5000h °C,<20.000h	125 100-130
Flammability class	UL94	-	V2
Comparative tracking index (CTI)	IEC60112	CTI CTIM	600 575(475)
Dielectric strength (1 mm thickness)	IEC60243-1	kV/mm	31
Surface resistivity	IEC60093	Ω	>10 <sup>15</sup>
Volume resistivity	IEC60093	Ω.cm	10 <sup>15</sup>
Tropical and termite resistance	-	-	good

## ■ EX Certificate

# Terminal blocks for Potentially Explosive Atmosphere and Hazardous Location (ATEX-Directive 2014/34/EU).

Now, RAAD Terminal Blocks can be used in potentially explosive environments.

To assure such capability, various tests, namely corrosion test, mechanical test and vibration test as well as ordinary tests are conducted on the terminal blocks.

All in all, IEC 60947-7-1, IEC 60947-7-2 and IEC 60947-7-3 standards pinpoint various mechanical, electrical and thermal requirements. Compliance with the mentioned standards is certified by an authorized certification body granting product certificates.

Further to these standards, requirements of EN 60079-0, EN 60079-7, EN50281-1-1 or IEC 61241-1 standards as well as ATEX-Directive 2014/34/EU are taken into consideration by an EU ATEX Notified Body to assure products' capability to be used in potentially explosive environments.

These terminal blocks were subjected to shock and vibration tests following the standards IEC/EN 60068-2-6 and IEC/EN 60068-2-27 respectively, carried out by TUV product service.

Consequently, the obtained certificates are " EC-TYPE Examination Certificate" on Products and "Production Quality Assurance Notification" on the quality management system, proving the fact that the products can be applied in potentially explosive environments.

In ATEX-Directive 2014/34/EU certificate, terminal block belongs to the components category, meaning that they must be applied in approved connection boxes for the type of protection "eb", increased safety, not need to be printed with CE.

## ■ EX Marking

### II2 G Ex eb IIC Gb

II2	Equipment group (II) and category (2)
G	Type of explosive atmosphere G-Gas vapor or mist
Ex	Explosion protection
eb	Increased safety
IIC	Electrical equipment group/a typical gas is hydrogen
Gb	Equipment protection level
FTZU 22 ATEX 0015U	Certification number
ATEX	Conformity with 2014/34/EU
U	Component
500V(Example)	Nominal voltage
4mm <sup>2</sup> (Example)	Nominal cross-section
32A	Nominal current

# Standards and Regulations

All RAAD Products are manufactured in accordance with the following latest edition of standards as minimum:

## IEC/EN 60947-7-1

Low-voltage switchgear and controlgear  
Part 7: Ancillary equipment  
Section 1: Terminal blocks for copper conductors

## IEC/EN 60947-7-2

Low-voltage switchgear and controlgear  
Part 7: Ancillary equipment  
Section 2: Protective conductor terminal blocks for copper conductors

## IEC/EN 60947-7-3

Low-voltage switchgear and controlgear  
Part 7: Ancillary equipment  
Section 3: Safety requirements for fuse terminal blocks

## IEC/EN 60947-1

Low-voltage switchgear and controlgear  
Part 1: General rules

## IEC/EN 60998-2-1

Connecting devices for low voltage circuits for household and similar purposes  
Part 2-1: Particular requirements for connecting devices as separate entities with screw-type clamping units

## IEC/EN 60998-1

Connecting devices for low voltage circuits for household and similar purposes  
Part 1: General requirements

## CSA CC 22.2 No.158

Terminal blocks

## IEC/EN 60695-11-5

Fire hazard testing  
Part 11-5: Test Flames-Needle-Flame test method

## IEC/EN 60068-2-6

Environmental testing  
Part 2-6: Tests: Vibration (sinusoidal)

## IEC/EN 60529

Classification of degrees of protection provided by enclosures (IP code)

## IEC/EN 60112

Methods for determining the comparative and the proof tracking indices of solid insulating materials under moist conditions

## IEC/EN 60243-1

Methods of test for electric strength of solid insulating materials  
Part 1: Tests at power frequencies

## IEC/EN 60093

Methods of testing of electrical insulating materials specific contact resistance and specific surface resistance of solid, electrically insulating materials

## IEC/EN 60664-1

Insulation coordination for equipment within low voltage systems  
Part 1: Principles, requirements and tests

## IEC/EN 60715

Dimensions of low-voltage switchgear and controlgear. Standardized mounting on rails for mechanical support of electrical devices in switchgear and controlgear installations

**IEC/EN 60079-0**

Electrical apparatus for explosive gas atmospheres

Part 0: General requirements

**UL 94**

Test for flammability of plastic materials for parts in devices and appliances

**EN 50085-2-3**

Cable trunking systems and cable ducting systems for electrical installations

part 2-3: particular requirements for slotted cable trunking systems intended for installations in cabinets.

**IEC 60884-1**

Plugs and socket-outlets for household and similar purposes

Part 1: General requirements

**IEC 61084-1**

Cable trunking and ducting systems for electrical installations

Part 1: General requirements

**IEC 60269-1**

Low-voltage fuses

Part 1: General requirement

**IEC/EN 60216-1**

Electrical insulating materials Properties of thermal endurance

Part 1: Ageing procedures and evaluation of test results

**IEC/EN 60695-2-10**

Fire hazard testing

Part 2-10: Glowing/hot-wire based test methods  
Glow-wire apparatus and common test procedure

**IEC/EN 60695-2-11**

Fire hazard testing

Part 2-11: Glowing/hot-wire based test methods  
Glow-wire flammability test method

**IEC/EN 60079-7**

Electrical apparatus for explosive gas atmospheres

Part 7: Increased safety 'e'

**UL 1059**

Standard for terminal blocks

**EN 50085-1**

Cable trunking systems and cable ducting systems for electrical installations

Part 1: General requirements

**IEC 60947-3**

Low-voltage switchgear and controlgear

Part 3: Switches, disconnectors, switch-disconnectors and fuse-combination units

**IEC 60947-5-1**

Low voltage switchgear and controlgear

part 5-1: Control circuit devices and switching elements-Electromechanical control circuit devices

**IEC 60947-2**

Low-voltage switchgear and control gear

Part 2: Circuit-breakers

**IEC 60898-1**

Electrical accessories-circuit-breakers for overcurrent protection for household and similar installations

Part 1: Circuit-breakers for a.c. operation

**IEC 61008-1**

Residual current operated circuit-breakers without integral overcurrent protection for household and similar uses (RCCBs)

Part 1: General rules

**IEC 61009-1**

Residual current operated circuit-breakers with integral overcurrent protection for household and similar uses (RCBOs)

Part 1: General rules

## Terminal block tests

IEC 60947-7-1 is the main standard which meets all types of RAAD terminal blocks. All RAAD products are designed, manufactured and tested in accordance with the standard, which along with 60947-7-1 determines the tests to be conducted on terminal blocks, each as a type test. Tests details are specified in the standards.

Below is an abstract of the foregoing tests.

### Attachment of the terminal block on its mounting rail

To assure the stability of the terminal block to its mounting rail, with standard shape and dimension values, a relevant test is conducted by inserting a 150 mm long steel pin with a diameter specified in table 3 of IEC 60947-7-1. It is connected to each clamping unit and a tightening torque must be applied, as given in table 4 of IEC 60947-1. Force must be applied to the pin with regular intensity and without tears; the corresponding value must be taken from table 3 of IEC 60947-7-1. The distance between the application point of the force and the centre of clamping unit must be equal to 100 mm. During the test, no terminal block must disengage from its mounting rail or suffer any damage.

IEC 60947-7-1 Attachment test parameters (Table3)			
Rated cross-section of terminal block		Force N	Diameter of pin mm
mm <sup>2</sup>	AWG/kcmil		
0.2	24		
0.34	22		
0.5	20		
0.75	18		
1.0	-	1	1.0
1.5	16		
2.5	14		
4	12		
6	10		
10	8	5	2.8
16	6		
25	4		
35	2	10	5.7
50	0		
70	00		
95	000		
-	0000		
120	250kcmil	15	12.8
150	300kcmil		
185	350kcmil		
240	500kcmil		
300	600kcmil	20	20.5

### Mechanical strength of terminals

To handle this test on screw-clamp terminal blocks, the rigid conductors must be used, which have the rated cross-section stated by the manufacture. The conductors must be connected and disconnected five times depending on the screw clamping, as determined in table 4 of IEC 60947-1. Where a screw is loosened, a new conductor must be applied. During the test, clamping units shall not work loose and there shall be no damage that will impair the further use of the screwed connections.

IEC 60947-1 Tightening torques for the verification of the mechanical strength of screw-type terminals (Table4)				
Metric standard values	Range of diameter	I	II	III
1.6	≥1.6	0.05	0.1	0.1
2.0	>1.6 up to and including 2.0	0.1	0.2	0.2
2.5	>2.0 up to and including 2.8	0.2	0.4	0.4
3.0	>2.8 up to and including 3.0	0.25	0.5	0.5
-	>3.0 up to and including 3.2	0.3	0.6	0.6
3.5	>3.2 up to and including 3.6	0.4	0.8	0.8
4.0	>3.6 up to and including 4.1	0.7	1.2	1.2
4.5	>4.1 up to and including 4.7	0.8	1.8	1.8
5	>4.7 up to and including 5.3	0.8	2.0	2.0
6	>5.3 up to and including 6.0	1.2	2.5	3.0
8	>6.0 up to and including 8.0	2.5	3.5	6.0
10	>8.0 up to and including 10.0	-	4.0	10.0
12	>10 up to and including 12	-	-	14.0
14	>12 up to and including 15	-	-	19.0
16	>15 up to and including 20	-	-	25.0
20	>20 up to and including 24	-	-	36.0
24	>24	-	-	50.0
Column I	Applies to screws without heads which, when tightened, do not protrude from the hole, and to other screws which cannot be tightened by means of a screwdriver with a blade wider than the root diameter of the screw.			
Column II	Applies to nuts and screws which are tightened by means of a screwdriver.			

### Damage and accidental loosening of conductors-flexion test

Specifically, this test is applied on terminal blocks suited for the connection of unprepared round copper conductors.

It is a must to test both rigid and flexible conductors with min. and max. cross-sections; optionally, connections of multiple conductors to a single clamping unit. A particular test apparatus is considered to aid the test performance. During the test, neither must the conductor slip out of the clamping unit, nor does breakage occur near the clamping unit. Soon after the flexion test, a pull-out test must occur without restoring the initial tightening torque.

## Pull-out test

After the flexion test was conducted, a pull-out is carried-out by force, the value of which is presented in table 5 of IEC 60947-1 to the conductor attached to the clamping unit; this force must be applied regularly and without tears, for 1 minute; for screw-clamp terminal blocks, the tightening screws must not be newly tightened. During the test, neither must the conductor slip out of the clamping unit, nor does breakage occur near the clamping unit.

IEC 60947-1 Test values for flexion and pull-out tests for round copper conductors (Table5)					
Conductor cross-section		Diameter of bushing hole <sup>a,b</sup>	Height $H^a$	Mass	Pulling force
mm <sup>2</sup>	AWG/kcmil	mm	mm	kg	n
0.2	24	6.5	260	0.2	10
0.34	22	6.5	260	0.2	15
0.5	20	6.5	260	0.3	20
0.75	18	6.5	260	0.4	30
1.0	-	6.5	260	0.4	35
1.5	16	6.5	260	0.4	40
2.5	14	9.5	280	0.7	50
4.0	12	9.5	280	0.9	60
6.0	10	9.5	280	1.4	80
10	8	9.5	280	2.0	90
16	6	13.0	300	2.9	100
25	4	13.0	300	4.5	135
-	3	14.5	320	5.9	156
35	2	14.5	320	6.8	190
-	1	15.9	343	8.6	236
50	0	15.9	343	9.5	236
70	00	19.1	368	10.4	285
95	000	19.1	368	14	351
-	0000	19.1	368	14	427
120	250kcmil	22.2	406	14	427
150	300kcmil	22.2	406	15	427
185	350kcmil	25.4	432	16.8	503
-	400kcmil	25.4	432	16.8	503
240	500kcmil	28.6	464	20	578
300	600kcmil	28.6	464	22.7	578

a) Tolerances: for height  $H \pm 15$  mm, for diameter of the bushing hole  $\pm 2$  mm.

b) If the bushing hole diameter is not large enough to accommodate the conductor without binding, a bushing having the next larger hole size may be used.

## Rated cross-section

It is the value of max connectable conductor cross-section. The rated cross-section shall be selected from the standard cross-sections presented in table 1, IEC 60947-7-1. Where a ferrule is applied on a flexible conductor, then a terminal block of one step higher rated cross-section must be used, for example, a 2.5 mm<sup>2</sup> flexible conductor covered with the relating ferrule must be inserted to a one step higher cross-section, i.e. terminal block with rated cross-section 4 mm<sup>2</sup>.

IEC 60947-7-1 Standard cross-sections of round copper conductors and approximate relationship between mm <sup>2</sup> and AWG/kcmil sizes (Table1)		
Rated cross-section mm <sup>2</sup>	AWG/kcmil size	Equivalent metric area mm <sup>2</sup>
0.2	24	0.205
0.34	22	0.324
0.5	20	0.519
0.75	18	0.82
1	-	-
1.5	16	1.3
2.5	14	2.1
4	12	3.3
6	10	5.3
10	8	8.4
16	6	13.3
25	4	21.2
35	2	33.6
-	1	42.4
50	0	53.5
70	00	67.4
95	000	85.0
-	0000	107.2
120	250kcmil	127
150	300kcmil	152
185	350kcmil	177
-	400kcmil	203
240	500kcmil	253
300	600kcmil	304

## Rated connection capacity

It is the range of cross-sections and the number of connectable conductors based on which the terminal blocks are designed. The IEC 60947-7-1 determines the relation between the rated cross-section and rating connecting capacity of terminal blocks. Practically, terminal blocks up to 35 mm<sup>2</sup>, must be possible to connect a conductor of cross-section equal to the nominal cross-section and lower up to two cross-sections.

## Insulation coordination for equipment within low voltage systems

IEC 60664-1 deals with insulation coordination for equipment within low voltage systems. It specifies the requirements for clearances, creepage distances and solid insulation for equipment based upon the performance criteria. Terminal blocks standard, IEC 60947-7-1, has the rules for coordination of insulation in accordance with IEC 60664-1.

## Degree of pollution

Degrees of pollution in the micro-environment

- **Pollution degree 1**

No pollution or only dry, non-conductive pollution occurs. The pollution has no influence.

- **Pollution degree 2**

Only non-conductive pollution occurs except that occasionally a temporary conductivity caused by condensation is to be expected.

- **Pollution degree 3**

Conductive pollution occurs or dry non-conductive pollution occurs which becomes conductive due to condensation which is to be expected.

- **Pollution degree 4**

The pollution generates persistent conductivity caused by conductive dust, rain or snow.

## Overvoltage categories and clearances

- Equipment of overvoltage category I is equipment for connection to circuits in which measures are taken to limit transient overvoltages to an appropriately low level. Examples for such devices are protected electronic circuits.
- Equipment of overvoltage category II is energy-consuming equipment to be supplied from the fixed installation. Examples of such equipment are appliances, portable tools and other household and similar loads.
- Equipment of overvoltage category III is equipment in fixed installations and for cases where the reliability and the availability of the equipment are subject to special requirements. Examples of such equipment are switches in fixed installation and equipment for industrial use with permanent connection to the fixed installation.
- Equipment of overvoltage category IV is for use at the origin of the installation. Examples of such equipment are electricity meters and primary over-current protection equipment.

EN 60664-1 Rated impulse voltage for equipment energized directly from the low-voltage mains (Table1)						
Nominal voltage of the supply system based on IEC 60038 <sup>2)</sup> V		Voltage line to neutral derived from normal voltages a.c. or d.c. up to and including V	Rated impulse voltage <sup>1)</sup> V			
Three phase	Single phase		Over voltage category			
			I	II	III	IV
		50	230	500	800	1500
		100	500	800	1500	2500
	120-240	150	800	1500	2500	4000
230/400 277/480		300	1500	2500	4000	6000
400/690		600	2500	4000	6000	8000
1000		1000	4000	6000	8000	12000

1) Equipment with these rated impulse voltages can be used in installation in accordance with IEC60364-4-443.

2) The / mark indicates a four-wire three-phase distribution system. The lower value is the voltage line-to-neutral, while the higher value is the voltage line-to-line. Where only one value is indicated, it refers to three-wire, three-phase systems and specifies value line-to-line.

IEC 60947-1 Minimum clearance in air (Table13)								
Rated impulse withstand voltage Uimp kV	Minimum clearances mm							
	Case A Inhomogeneous field conditions (see 2.5.63)				Case B Homogeneous field ideal conditions (see 2.5.62)			
	Pollution degree				Pollution degree			
	1	2	3	4	1	2	3	4
0.33	0.01				0.01			
0.5	0.04	0.2			0.04	0.2		
0.8	0.1			1.6	0.1		0.8	1.6
1.5	0.5	0.5			0.3	0.3		
2.5	1.5	1.5	1.5		0.6	0.6		
4.0	3	3	3	3	1.2	1.2	1.2	
6.0	5.5	5.5	5.5	5.5	2	2	2	2
8.0	8	8	8	8	3	3	3	3
12	14	14	14	14	4.5	4.5	4.5	4.5

**NOTE:** The values of minimum clearance in air are based on 1,2/50 ms impulse voltage, for barometric pressure of 80 kPa, equivalent to normal atmospheric pressure at 2000 m above sea level.

## Material groups

According to the range of values of the comparative tracking index (CTI), material groups are classified as follows:

- Material Group I  $600 \leq CTI$
- Material Group II  $400 \leq CTI < 600$
- Material Group IIIa  $175 \leq CTI < 400$
- Material Group IIIb  $100 \leq CTI < 175$

The CTI values refer to values obtained in accordance with IEC 60112, method A, for the insulating material used.

## Creepage distances

The creepage distance is based on the rated voltage which is derived from the working voltage or nominal voltage of the supply system. The minimum creepage distances are allocated to the rated voltage according to the pollution degree and material group in table 15, IEC 60947-1.

In this catalog the products must be measured in compliance with IEC 60664-1 for overvoltage category III, pollution degree 3 and material group I, otherwise the product information would include additional details.

IEC 60947-1															
Minimum creepage distances (Table15)															
Rated insulation voltage of equipment or working voltage a.c. r.m.s or d.c. <sup>4)</sup> V	Creepage distances for equipment subject to long term stress mm														
	Pollution degree			Pollution degree				Pollution degree				Pollution degree			
	1 <sup>5)</sup>	2 <sup>5)</sup>	1	2		3		3		3		4			
	Material group			Material group				Material group				Material group			
	1)	2)	1)	I	II	IIIa	IIIb	I	II	IIIa	IIIb	I	II	IIIa	IIIb
10	0.025	0.04	0.08	0.4	0.4	0.4	0.4	1	1	1	1	1.6	1.6	1.6	
12.5	0.025	0.04	0.09	0.42	0.42	0.42	0.42	1.05	1.05	1.05	1.05	1.6	1.6	1.6	
16	0.025	0.04	0.1	0.45	0.45	0.45	0.45	1.1	1.1	1.1	1.1	1.6	1.6	1.6	
20	0.025	0.04	0.11	0.48	0.48	0.48	0.48	1.2	1.2	1.2	1.2	1.6	1.6	1.6	
25	0.025	0.04	0.125	0.5	0.5	0.5	0.5	1.25	1.25	1.25	1.25	1.7	1.7	1.7	
32	0.025	0.04	0.14	0.53	0.53	0.53	0.53	1.3	1.3	1.3	1.3	1.8	1.8	1.8	
40	0.025	0.04	0.16	0.56	0.8	1.1	1.1	1.4	1.6	1.8	1.8	1.9	2.4	3	
50	0.025	0.04	0.18	0.6	0.85	1.2	1.2	1.5	1.7	1.9	1.9	2	2.5	3.2	
63	0.04	0.063	0.2	0.63	0.9	1.25	1.25	1.6	1.8	2	2	2.1	2.6	3.4	
80	0.063	0.1	0.22	0.67	0.95	1.3	1.3	1.7	1.9	2.1	2.1	2.2	2.8	3.6	
100	0.1	0.16	0.25	0.71	1	1.4	1.4	1.8	2	2.2	2.2	2.4	3	3.8	
125	0.16	0.25	0.28	0.75	1.05	1.5	1.5	1.9	2.1	2.4	2.4	2.5	3.2	4	
160	0.25	0.4	0.32	0.8	1.1	1.6	1.6	2	2.2	2.5	2.5	3.2	4	5	
200	0.4	0.63	0.42	1	1.4	2	2	2.5	2.8	3.2	3.2	4	5	6.3	
250	0.56	1	0.56	1.25	1.8	2.5	2.5	3.2	3.6	4	4	5	6.3	8	
320	0.75	1.6	0.75	1.6	2.2	3.2	3.2	4	4.5	5	5	6.3	8	10	
400	1	2	1	2	2.8	4	4	5	5.6	6.3	6.3	8	10	12.5	
500	1.3	2.5	1.3	2.5	3.6	5	5	6.3	7.1	8	8	10	12.5	16	
630	1.8	3.2	1.8	3.2	4.5	6.3	6.3	8	9	10	10	12.5	16	20	
800	2.4	4	2.4	4	5.6	8	8	10	11	12.5	12.5	16	20	25	3)
1000	3.2	5	3.2	5	7.1	10	10	12.5	14	16	16	20	25	32	
1250			4.2	6.3	9	12.5	12.5	16	18	20	20	25	32	40	
1600			5.6	8	11	16	16	20	22	25	25	32	40	50	
2000			7.5	10	14	20	20	25	28	32	32	40	50	63	
2500			10	12.5	18	25	25	32	36	40	40	50	63	80	
3200			12.5	16	22	32	32	40	45	50	50	63	80	100	
4000			16	20	28	40	40	50	56	63	63	80	100	125	
5000			20	25	36	50	50	63	71	80	80	100	125	160	
6300			25	32	45	63	63	80	90	100	100	125	160	200	
8000			32	40	56	80	80	100	110	125	125	160	200	250	
10000			40	50	71	100	100	125	140	160	160	200	250	320	

1) Material groups I, II, IIIa, IIIb.

2) Material groups I, II, IIIa.

3) Values of creepage distances in this area have not been established. Material groups IIIb is in general not recommended for application in pollution degree 3 above 630 V and in pollution degree 4.

4) As an exception, for rated insulation voltages 127 V, 208 V, 415/440 V, 660/690 V and 830 V, creepage distances corresponding to the lower values 125 V, 200 V, 400 V, 630 V and 800 V respectively may be used.

5) The values given in these two columns apply to creepage distances of printing circuit materials.

6) The values of creepage distances stated for 250 V can be used for 230 V ( $\pm 10\%$ ) normal voltage.

**NOTE 1 :** It is appreciated that tracking or erosion will not occur on insulation subjected to working voltages of 32 V and below. However, the possibility of electrolytic corrosion has to be considered and for this reason minimum creepage distances have been specified.

**NOTE 2 :** Voltage values are selected in accordance with the R<sub>10</sub> series.

## Dielectric test

The test is conducted on 5 adjacent terminal blocks, mounted on a metallic mounting rail and connected with rated cross-section conductors.

Test voltage must have a sinusoidal waveform with a frequency between 45 and 62 Hz.

The values applied, for 5 seconds, are those specified in the table 12A, IEC 60947-1. Irrespective of glow discharges without drop of voltage, no disruptive discharges shall occur during the test.

IEC 60947-1 Dielectric test voltage corresponding to the rated insulation voltage (Table 12A)		
Rated insulation voltage $U_i$ V	AC test voltage (r.m.s.) V	DC test voltage <sup>2), 3)</sup> V
$U_i \leq 60$	1000	1415
$60 < U_i \leq 300$	1500	2120
$300 < U_i \leq 690$	1890	2670
$690 < U_i \leq 800$	2000	2830
$800 < U_i \leq 1000$	2200	3110
$1000 < U_i \leq 1500^{1)}$	-	3820

1) For d.c. only.

2) Test voltages based on 4.1.2.3.1, third paragraph of IEC 60664-1.

3) A direct current test voltage may be used only if an alternating test voltage cannot be applied. See also 3) b) ii) of 8.3.3.4.1.

## Short-time withstand current

The standard IEC 60947-7-1 obliges terminal blocks to withstand a current equal to 120A per each square mm of rated cross-section for 1 second.

## Voltage drop

Voltage drop at the terminal indicates an index of contact resistance against the follow of current. The voltage drop test is conducted before and after mechanical strength, short-time withstand current and temperature-rise tests. IEC 60947-7-1 states that the voltage drop, measured on a new terminal block, must be lower than 3.2 mV and after the tests lower than 150 % of the value measured before the tests.

## Temperature-rise test

The current in a terminal block causes overheating due to continuous operation. The overheating level shall not overcome a specified value, thus a temperature-rise test is applied to verify this performance requirement. The test is conducted by means of temperature-rise test on 5 neighboring terminal blocks connected at a test current as specified in table 4, IEC 60947-7-1. The temperature-rise of any part of the centrally located terminal block shall not exceed 45 K.

IEC 60947-7-1 Values of test current for temperature-rise test, ageing test and voltage drop test for metric wire sizes (Table 4)			
Rated cross-section mm <sup>2</sup>	Test current A	Rated cross-section mm <sup>2</sup>	Test current A
0.2	4	25	101
0.5	6	35	125
0.75	9	50	150
1	13.5	70	192
1.5	17.5	95	232
2.5	24	120	269
4	32	150	309
6	41	185	353
10	57	240	415
16	76	300	520

## Verification of thermal characteristics

The thermal characteristics are checked by the needle flame test.

The test is carried out according to IEC60695-11-5 successively in the area of one clamping unit of three terminal blocks.

The test flame is applied to the surface of test specimen and removing after the specified time.

With no any glowing of the test specimen or extinguishing the sample within 30s, the test is passed.

## Vibration and shock resistant

- **Shock Test**

The purpose of this test is to reveal mechanical weakness and/or degradation in specified performances or accumulated damage or degradation caused by shocks.

The following test is done in accordance with required by the specifications: shock test to BS EN 60068-2-27

Shock pulse: Half sine

Acceleration: 40g

Pulse duration: 6ms

Test directions: In all three major orthogonal axes

Number of shocks: 1000 in each axis

Total number: 3000

- **Vibration Test**

The purpose of this test is to determine the ability of components, equipments and other articles to withstand any mechanical weakness and/or degradation caused by vibration.

The following test is done in accordance with required by the specifications: swept sine vibration to BS EN 60068-2-6

Frequency range: 55 Hz to 2000 Hz

Test levels: 55 Hz to 58.1 Hz : 1.5mm displacement peak to peak

58.1 Hz to 2000 Hz: 100 m/s<sup>2</sup> (10g)

Vibration directions: In all three major orthogonal axes

Duration: 10 swept cycles in each axis

Sweep rate: 1 octave/minute

## ■ Wiring Duct Tests

The following tests as type tests should be carried out for testing of wiring ducts in accordance with the main standards EN 50085-1 and EN 50085-2-3:

### Check marking

Each system component shall be marked with:

The manufacturer's or responsible vendor's name or trade mark or identification mark,

A product identification mark, which may be, for example a catalog number, a symbol or the like.

### Cable support test

Each test is made on one sample of slotted trunking length having a length of about 250 mm.

The sample is securely fixed to a rigid support. Then the sample is subjected to an evenly distributed load of 0.8 g/mm<sup>2</sup> for metre length of the declared usable area for cables.

The load consists of copper cables, half load cables of 25 mm<sup>2</sup> nominal cross section and other half cables of 2.5 mm<sup>2</sup> nominal cross section. This load is preserved for 2 h in climatic chamber to 60 °C.

After about 2 h, with the load still applied, the distortion shall not exceed 10% of the height with a maximum of 10 mm.

The same result shall be obtained for the width.

### Impact test for storage and transport

The test is carried out on the samples of trunking lengths each about 250 mm long.

Before the test, the samples are aged at the temperature of 70 °C for 168 h continuously.

The test apparatus consists basically of a hammer which falls freely from rest, through a vertical height on to an intermediate part placed on the sample held in a horizontal plane.

The mass of the hammer is 0.5 kg and the fall height is 100 mm.

The samples are placed in a refrigerator at the temperature of -45° C for 2 h.

Within 10 s after the removal of the sample from the refrigerator the hammer is allowed to fall so that an impact is applied to the centre of the cover or the centre of the bottom of the base .

After the test, the samples shall show no signs of disintegration nor shall there be any cracks, that are likely to impair safety.

### Insulation resistance test

Before the test, the sample shall be placed in the humidity cabinet with a relative humidity between 91% and 95% at a temperature maintained between 25 °C and 30 °C. The samples are kept in the cabinet for 120 h.

Immediately after conditioning, two conductive foils used as electrodes are applied, one to the outer surface and one to the inner surface of the sample .

The insulation resistance is measured by applying a d.c. voltage of 500 V between the electrodes.

The measurement is made 60 s after the application of the voltage.

The insulation resistance shall not be less than 100 MΩ.

## Resistance to heat

Immediately after the insulation resistance test, a voltage of  $(2 U_n + 1000)$  V, where  $U_n$  is the rated voltage of substantially sine-wave form and having a nominal frequency of 50 Hz, is then applied between electrodes.

Initially not more than half the voltage is applied and then it is raised to the test voltage as rapidly as possible without transient over voltage.

The voltage is maintained for about 5 s.

No flashover or breakdown shall occur during the test.

## Resistance to heat

The part under the test shall be placed on a 3 mm thick steel plate in direct contact with it so as to be supported to withstand the test force .

When it is not possible to carry out the test on the sample, the test shall be carried out on a piece of the same material with at least 2 mm thick .

The surface of the part to be tested is placed in the horizontal position and a steel ball of 5 mm diameter is pressed against the surface with a force of 20 N .

The test is carried out in a heating cabinet at the temperature of 70 °C.

After 1 h, the ball is removed from the sample which is then cooled down within 10 s to approximately room temperature by immersion in cold water.

The diameter of the impression caused by the ball is measured and shall not exceed 2 mm.

## Resistance to flame propagation (needle flame test)

This test is carried out in according to standard EN 60695-11-5 at the following conditions.

The test is made on two sets of samples whose length is about 675 mm.

The sample is placed vertically with its lower extremity about 100 mm above the tissue covered pinewood board, in a rectangular metal enclosure with an open face.

It shall be securely fixed to a rigid support through the fixing holes, in the base of the trunking.

The burner (needle flame) is positioned on the sample in such a way that the axis forms an angle of about 45° with the horizontal one, and the flame is applied centrally to the boundary of an opening of the wall approximately 200 mm above the wrapping tissue covered pinewood board, the end of the burner tube being distanced 5 mm from the sample.

The test is repeated but with the burner applied to one extremity of the cover.

The sample is subjected to the exposure of the flame for 60 s each time.

The sample is regarded as having passed the test if:

- it does not ignite ; or if
- in the case of ignition, the flames or glowing of the sample extinguish within 30 s after removal of the test flame and there is no ignition of the wrapping tissue or scorching of the pinewood board.

## Fire hazard

Compliance is checked by glow wire test in accordance with the standards EN 50085-1 and EN 60695-2-11.

# Symbols

In circuit diagrams, the following symbols have been used as minimum:

Clamp		Break contact	
Test Socket connection		Switch disconnecter	
Resistor		Make contact	
Diode		Thermal effect	
Bipolar LED		manually operated switch	
Fuse		Electromagnetic effect	
Neon Lamp		Relay coil	
Ground		Actuator (operated by pushing)	
Moveable Link		Amplification	
Sliding Connection		Alternating current	
Bridge Comb / Bridge screwless		Current transformer	
Circuit breaker		Lowest operational ambient temperature	

The applicability of Test Sockets are shown in the schematic diagrams of only test/disconnect terminal blocks, for its usage on other terminal blocks, refer to related descriptions..



# Modular Terminal Blocks

## Universal Terminal Blocks

Type	Ordering No.	Qty (Box)	Qty (Carton)	Page	Type	Ordering No.	Qty (Box)	Qty (Carton)	Page
RT/SU2.5 Blue	6010402001	100	1000	20	RT/SU10 Yellow	6010405004	60	900	22
RT/SU2.5 Green	6010402002	100	1000	20	RT/SU10 Gray	6010405005	60	900	22
RT/SU2.5 White	6010402003	100	1000	20	RT/SU10 Red	6010405006	60	900	22
RT/SU2.5 Yellow	6010402004	100	1000	20	RT/SU10 Brown	6010405007	60	900	22
RT/SU2.5 Gray	6010402005	100	1000	20	RT/SU10 Light Cream	6010405008	60	900	22
RT/SU2.5 Red	6010402006	100	1000	20	RT/SU10 Black	6010405009	60	900	22
RT/SU2.5 Brown	6010402007	100	1000	20	RT/SU10 Orange	6010405010	60	900	22
RT/SU2.5 Light Cream	6010402008	100	1000	20	RT/SU16 Blue	6010406001	50	500	22
RT/SU2.5 Black	6010402009	100	1000	20	RT/SU16 Green	6010406002	50	500	22
RT/SU2.5 Orange	6010402010	100	1000	20	RT/SU16 White	6010406003	50	500	22
RT/SU2.5-H Blue	6010401001	100	1000	20	RT/SU16 Yellow	6010406004	50	500	22
RT/SU2.5-H Green	6010401002	100	1000	20	RT/SU16 Gray	6010406005	50	500	22
RT/SU2.5-H White	6010401003	100	1000	20	RT/SU16 Red	6010406006	50	500	22
RT/SU2.5-H Yellow	6010401004	100	1000	20	RT/SU16 Brown	6010406007	50	500	22
RT/SU2.5-H Gray	6010401005	100	1000	20	RT/SU16 Light Cream	6010406008	50	500	22
RT/SU2.5-H Red	6010401006	100	1000	20	RT/SU16 Black	6010406009	50	500	22
RT/SU2.5-H Brown	6010401007	100	1000	20	RT/SU16 Orange	6010406010	50	500	22
RT/SU2.5-H Light Cream	6010401008	100	1000	20	RT/SU25 Blue	6010407001	50	500	23
RT/SU2.5-H Black	6010401009	100	1000	20	RT/SU25 Green	6010407002	50	500	23
RT/SU2.5-H Orange	6010401010	100	1000	20	RT/SU25 White	6010407003	50	500	23
RT/SU4 Blue	6010403001	100	1000	21	RT/SU25 Yellow	6010407004	50	500	23
RT/SU4 Green	6010403002	100	1000	21	RT/SU25 Gray	6010407005	50	500	23
RT/SU4 White	6010403003	100	1000	21	RT/SU25 Red	6010407006	50	500	23
RT/SU4 Yellow	6010403004	100	1000	21	RT/SU25 Brown	6010407007	50	500	23
RT/SU4 Gray	6010403005	100	1000	21	RT/SU25 Light Cream	6010407008	50	500	23
RT/SU4 Red	6010403006	100	1000	21	RT/SU25 Black	6010407009	50	500	23
RT/SU4 Brown	6010403007	100	1000	21	RT/SU25 Orange	6010407010	50	500	23
RT/SU4 Light Cream	6010403008	100	1000	21	RT/SU35 Blue	6010408001	20	320	23
RT/SU4 Black	6010403009	100	1000	21	RT/SU35 Green	6010408002	20	320	23
RT/SU4 Orange	6010403010	100	1000	21	RT/SU35 White	6010408003	20	320	23
RT/SU6 Blue	6010404001	80	1200	21	RT/SU35 Yellow	6010408004	20	320	23
RT/SU6 Green	6010404002	80	1200	21	RT/SU35 Gray	6010408005	20	320	23
RT/SU6 White	6010404003	80	1200	21	RT/SU35 Red	6010408006	20	320	23
RT/SU6 Yellow	6010404004	80	1200	21	RT/SU35 Brown	6010408007	20	320	23
RT/SU6 Gray	6010404005	80	1200	21	RT/SU35 Light Cream	6010408008	20	320	23
RT/SU6 Red	6010404006	80	1200	21	RT/SU35 Black	6010408009	20	320	23
RT/SU6 Brown	6010404007	80	1200	21	RT/SU35 Orange	6010408010	20	320	23
RT/SU6 Light Cream	6010404008	80	1200	21	RT/SU50 Blue	6010409001	20	200	24
RT/SU6 Black	6010404009	80	1200	21	RT/SU50 Green	6010409002	20	200	24
RT/SU6 Orange	6010404010	80	1200	21	RT/SU50 White	6010409003	20	200	24
RT/SU10 Blue	6010405001	60	900	22	RT/SU50 Yellow	6010409004	20	200	24
RT/SU10 Green	6010405002	60	900	22	RT/SU50 Gray	6010409005	20	200	24
RT/SU10 White	6010405003	60	900	22	RT/SU50 Red	6010409006	20	200	24



Type	Ordering No.	Qty (Box)	Qty (Carton)	Page
RT/SU50 Brown	6010409007	20	200	24
RT/SU50 Light Cream	6010409008	20	200	24
RT/SU50 Black	6010409009	20	200	24
RT/SU50 Orange	6010409010	20	200	24
RT/SU70 Gray	6010410005	10	50	24
RT/SU70 Blue	6010410006	10	50	24
RT/SU70 Black	6010410009	10	50	24

Type	Ordering No.	Qty (Box)	Qty (Carton)	Page
RT/SU95 Blue	6010411001	5	50	25
RT/SU95 Gray	6010411005	5	50	25
RT/SU95 Black	6010411009	5	50	25
RT/SU150 Blue	6010412001	5	50	25
RT/SU150 Gray	6010412005	5	50	25
RT/SU150 Black	6010412009	5	50	25

### Protective Conductor Terminal Blocks

Page 27

Type	Ordering No.	Qty (Box)	Qty (Carton)	Page
RT/SU2.5-E	6010601001	50	500	26
RT/SU4-E	6010601002	50	500	26
RT/SU6-E	6010601003	25	500	27
RT/SU10-E	6010601004	25	500	27
RT/SU16-E	6010601005	20	340	28
RT/SU35-E	6010601006	20	200	28

Type	Ordering No.	Qty (Box)	Qty (Carton)	Page
RT/SU2.5-SO	6010602001	50	500	29
RT/SU4-SO	6010602002	50	500	29
RT/SU6-SO	6010602003	25	500	30
RT/SU10-SO	6010602004	20	400	30

### Multi Level Terminal Blocks

Page 35

Type	Ordering No.	Qty (Box)	Qty (Carton)	Page
RT/SU2.5/4-2L Blue	6010728001	50	600	37
RT/SU2.5/4-2L Gray	6010728005	50	600	37
RT/SU2.5/4-2L-SL Blue	6010728011	50	600	35
RT/SU2.5/4-2L-SL Gray	6010728015	50	600	35
RT/SU4-2L Blue	6010701001	50	800	38
RT/SU4-2L Green	6010701002	50	800	38
RT/SU4-2L Yellow	6010701004	50	800	38
RT/SU4-2L Gray	6010701005	50	800	38
RT/SU4-2L Red	6010701006	50	800	38
RT/SU4-2L Brown	6010701007	50	800	38
RT/SU4-2L Black	6010701009	50	800	38
RT/SU4-2L Orange	6010701010	50	800	38
RT/SU4-2L-D1 Green	6010702002	50	800	38
RT/SU4-2L-D1 Gray	6010702005	50	800	38
RT/SU4-2L-D2)	6010703005	50	800	38
RT/SU4-2L-D3)	6010704005	50	800	38
RT/SU4-2L-D4)	6010705005	50	800	38
RT/SU4-2L-D5 Green	6010706002	50	800	38
RT/SU4-2L-D5	6010706005	50	800	38
RT/SU4-2L-D6	6010707005	50	800	38
RT/SU4-2L-D7	6010708001	50	800	38
RT/SU4-2L-D8	6010709001	50	800	38
RT/SU4-2L-DR1	6010720005	50	800	38
RT/SU4-2L-DR2	6010721005	50	800	38

Type	Ordering No.	Qty (Box)	Qty (Carton)	Page
RT/SU4-2L-LD 24-48VAC/DC	6010722005	50	800	38
RT/SU4-2L-LD 110-220VAC/DC	6010722006	50	800	38
RT/SU4-2L-R2	6010724005	50	800	38
RT/SU4-2L-R2.2k	6010725005	50	800	38
RT/SU4-2L-R125	6010726005	50	800	38
RT/SU4-2L-L	6010727005	50	800	38
RT/SU2.5/4-2L-LD 24-48VAC/DC	6010730005	50	600	38
RT/SU2.5/4-2L-LD 110-220VAC/DC	6010730006	50	600	38
RT/SU2.5/4-2L-D4	6010734001	50	600	38
RT/SU4-3L	6010750005	25	500	36
RT/SU10-2L Gray	6010740005	25	250	37
RT/SU2.5-3LE5	6020206002	30	600	37

## Test Disconnect Terminal Blocks

Page 41

Type	Ordering No.	Qty (Box)	Qty (Carton)	Page	Type	Ordering No.	Qty (Box)	Qty (Carton)	Page
RT/ST6	6010301001	20	320	42	RT/ST6-CMP	6010306001	25	500	42
RT/ST6-L	6010302001	20	320	42	RSTN6-1	6010306002	25	500	42
RT/ST6-SHT	6010303001	25	500	41	RT/SP6	6010304001	25	500	42
RT/ST6-SHT-L	6010305001	25	500	41					

## Disconnect and Component Terminal Blocks

Page 47

Type	Ordering No.	Qty (Box)	Qty (Carton)	Page	Type	Ordering No.	Qty (Box)	Qty (Carton)	Page
RT/SK2.5	6010801001	50	900	46	RT/SK2.5-R-4.7k	6010801012	25	500	47
RT/SK2.5-TS	6010801006	25	500	46	RT/SK2.5-R-10k	6010801013	25	500	47
RT/SK2.5 Blue	6010801020	25	500	46	RT/SK2.5-R-2.2k-2w	6010801014	25	500	47
RT/SK2.5-D	6010801002	50	900	47	RT/SK2.5-R-5k-2w	6010801015	25	500	47
RT/SK2.5-R	6010801007	25	500	47	RT/SK2.5-R-5.6k-2w	6010801021	25	500	47
RT/SK2.5-R-1k-1w	6010801008	25	500	47	RT/SK2.5-D-1N4007-150v	6010801016	25	500	47
RT/SK2.5-R-2k	6010801009	25	500	47	RDT2.5-D-Cap	6020701001	50	-	47
RT/SK2.5-R-2.2k-1w	6010801010	25	500	47	RDT2.5-CRC 4.7K-2w	6020701002	50	-	47
RT/SK2.5-R-4.3k	6010801011	25	500	47	RDT2.5-CRC 2.2K-2w	6020701003	50	-	47

## Fuse Terminal Blocks

Page 51

Type	Ordering No.	Qty (Box)	Qty (Carton)	Page	Type	Ordering No.	Qty (Box)	Qty (Carton)	Page
RT/SF4 Gray	6010201001	25	500	52	RT/SK2.5-FLD Blue 110-220VAC/DC	6010801019	25	500	53
RT/SF4 Blue	6010201002	25	500	52	RT/SK2.5-F-Cap 24-48VAC/DC	6020702001	50	500	53
RT/SF4 Black	6010201003	25	500	52	RT/SK2.5-F-Cap 110-220VAC/DC	6020702002	50	500	53
RT/SF4-LD Gray 24-48VAC/DC	6010202001	25	500	52	RT/SK2.5-F-Cap	6020702003	50	500	53
RT/SF4-LD Gray 110-220VAC/DC	6010202002	25	500	52	RT/SF4-2L	6010204001	20	400	54
RT/SF4-LD Black 24-48VAC/DC	6010202003	25	500	52	RT/SF4-2L-LD 24-48VAC/DC	6010204002	20	400	54
RT/SF4-LD Black 110-220VAC/DC	6010202004	25	500	52	RT/SF4-2L-LD 110-220VAC/DC	6010204003	20	400	54
RT/SF4-LD Blue 24-48VAC/DC	6010202005	25	500	52					
RT/SF4-LD Blue 110-220VAC/DC	6010202006	25	500	52					
RT/SK2.5-F Gray	6010801003	25	500	53					
RT/SK2.5-F Blue	6010801017	25	500	53					
RT/SK2.5-FLD 24-48VAC/DC	6010801004	25	500	53					
RT/SK2.5-FLD 110-220VAC/DC	6010801005	25	500	53					
RT/SK2.5-FLD Blue 24-48VAC/DC	6010801018	25	500	53					

■ General Terminal Blocks

Type	Ordering No.	Qty (Box)	Qty (Carton)	Page	Type	Ordering No.	Qty (Box)	Qty (Carton)	Page
RT/SG2.5 Gray	6010421005	100	-	56	RT/SG6 Red	6010423006	65	-	57
RT/SG2.5 Blue	6010421001	100	-	56	RT/SG6 Brown	6010423007	65	-	57
RT/SG2.5 Green	6010421002	100	-	56	RT/SG6 Black	6010423009	65	-	57
RT/SG2.5 White	6010421003	100	-	56	RT/SG6 Orange	6010423010	65	-	57
RT/SG2.5 Yellow	6010421004	100	-	56	RT/SG10 Gray	6010424005	50	-	57
RT/SG2.5 Red	6010421006	100	-	56	RT/SG10 Blue	6010424001	50	-	57
RT/SG2.5 Brown	6010421007	100	-	56	RT/SG10 Green	6010424002	50	-	57
RT/SG2.5 Black	6010421009	100	-	56	RT/SG10 White	6010424003	50	-	57
RT/SG2.5 Orange	6010421010	100	-	56	RT/SG10 Yellow	6010424004	50	-	57
RT/SG4 Gray	6010422005	85	-	56	RT/SG10 Red	6010424006	50	-	57
RT/SG4 Blue	6010422001	85	-	56	RT/SG10 Brown	6010424007	50	-	57
RT/SG4 Green	6010422002	85	-	56	RT/SG10 Black	6010424009	50	-	57
RT/SG4 White	6010422003	85	-	56	RT/SG10 Orange	6010424010	50	-	57
RT/SG4 Yellow	6010422004	85	-	56	RT/SG2.5-2L	6010744005	30	-	58
RT/SG4 Red	6010422006	85	-	56	RT/SG4-2L	6020101001	20	-	58
RT/SG4 Brown	6010422007	85	-	56	RT/SG2.5-2LE	6010744015	30	-	59
RT/SG4 Black	6010422009	85	-	56	RT/SG4-2LE	6010603015	30	-	59
RT/SG4 Orange	6010422010	85	-	56	RT/SF4-2L	6010204001	20	-	59
RT/SG6 Gray	6010423005	65	-	57	RT/SF4-2L-LD 24,48VAC/DC	6010204002	20	-	59
RT/SG6 Blue	6010423001	65	-	57	RT/SF4-2L-LD 110,220VAC/DC	6010204002	20	-	59
RT/SG6 Green	6010423002	65	-	57					
RT/SG6 White	6010423003	65	-	57					
RT/SG6 Yellow	6010423004	65	-	57					

■ Protective General Terminal Blocks

Type	Ordering No.	Qty (Box)	Qty (Carton)	Page	Type	Ordering No.	Qty (Box)	Qty (Carton)	Page
RT/SG2.5-E	6010604001	70	-	62	RT/SG10-E	6010604004	35	-	63
RT/SG4-E	6010604002	60	-	62	RT/SG2.5-2L2E	6010744016	30	-	64
RT/SG6-E	6010604003	45	-	63	RT/SG4-2L2E	6011203003	30	-	64

## Push-In Connection Terminal Blocks

Page 67

Type	Ordering No.	Qty (Box)	Qty (Carton)	Page	Type	Ordering No.	Qty (Box)	Qty (Carton)	Page
RT/PG2.5 Blue	6011001001	100	1000	70	RT/PG6 Red	6011003006	50	500	71
RT/PG2.5 Green	6011001002	100	1000	70	RT/PG6 Brown	6011003007	50	500	71
RT/PG2.5 White	6011001003	100	1000	70	RT/PG6 Light Cream	6011003008	50	500	71
RT/PG2.5 Yellow	6011001004	100	1000	70	RT/PG6 Black	6011003009	50	500	71
RT/PG2.5 Gray	6011001005	100	1000	70	RT/PG6 Orange	6011003010	50	500	71
RT/PG2.5 Red	6011001006	100	1000	70	RT/PG10 Blue	6011004001	30	600	71
RT/PG2.5 Brown	6011001007	100	1000	70	RT/PG10 Green	6011004002	30	600	71
RT/PG2.5 Light Cream	6011001008	100	1000	70	RT/PG10 White	6011004003	30	600	71
RT/PG2.5 Black	6011001009	100	1000	70	RT/PG10 Yellow	6011004004	30	600	71
RT/PG2.5 Orange	6011001010	100	1000	70	RT/PG10 Gray	6011004005	30	600	71
RT/PG4 Blue	6011002001	100	800	70	RT/PG10 Red	6011004006	30	600	71
RT/PG4 Green	6011002002	100	800	70	RT/PG10 Brown	6011004007	30	600	71
RT/PG4 White	6011002003	100	800	70	RT/PG10 Light Cream	6011004008	30	600	71
RT/PG4 Yellow	6011002004	100	800	70	RT/PG10 Black	6011004009	30	600	71
RT/PG4 Gray	6011002005	100	800	70	RT/PG10 Orange	6011004010	30	600	71
RT/PG4 Red	6011002006	100	800	70	RT/PG16 Gray	6011007005	25	500	70
RT/PG4 Brown	6011002007	100	800	70	RT/PG16 Blue	6011007001	25	500	70
RT/PG4 Light Cream	6011002008	100	800	70	RT/PG16 Yellow	6011007004	25	500	70
RT/PG4 Black	6011002009	100	800	70	RT/PG16 Green	6011007002	25	500	70
RT/PG4 Orange	6011002010	100	800	70	RT/PG16 White	6011007003	25	500	70
RT/PG6 Blue	6011003001	50	500	71	RT/PG16 Red	6011007006	25	500	70
RT/PG6 Green	6011003002	50	500	71	RT/PG16 Brown	6011007007	25	500	70
RT/PG6 White	6011003003	50	500	71	RT/PG16 Black	6011007009	25	500	70
RT/PG6 Yellow	6011003004	50	500	71	RT/PG16 Orange	6011007010	25	500	70
RT/PG6 Gray	6011003005	50	500	71					

## Earth Push-In Protective Terminal Blocks

Page 75

Type	Ordering No.	Qty (Box)	Qty (Carton)	Page	Type	Ordering No.	Qty (Box)	Qty (Carton)	Page
RT/PG2.5-E	6011201001	50	500	74	RT/PG10-E	6011201004	20	400	75
RT/PG4-E	6011201002	50	500	74	RT/PG16-E	6011201005	25	500	76
RT/PG6-E	6011201003	25	500	75	RT/PG4-2L2E	6011201002	50	-	76

## Multi Level Push-In Terminal Blocks

Page 81

Type	Ordering No.	Qty (Box)	Qty (Carton)	Page	Type	Ordering No.	Qty (Box)	Qty (Carton)	Page
RT/PG2.5-2L	6011101001	50	500	80	RT/PG2.5-3LOE5	6011202001	30	600	81
RT/PG4-2L	6011102005	50	500	80	RT/PG2.5-3L Gray	6011103001	28	-	84
RT/PG4-2LE	6011203002	50	-	81	RT/PG2.5-3L Blue	6011103002	28	-	84

## Multi Conductor Push-In Terminal Blocks

Page 87

Type	Ordering No.	Qty (Box)	Qty (Carton)	Page
RT/PG2.5-1/2 Gray	6011005005	40	400	84
RT/PG2.5-1/2 Black	6011005009	40	400	84
RT/PG2.5-2/2	6011006001	40	400	84

## Disconnect Push-in Terminal Blocks

Page 87

Type	Ordering No.	Qty (Box)	Qty (Carton)	Page	Type	Ordering No.	Qty (Box)	Qty (Carton)	Page
RT/PK2.5 Gray	6011600003	30	-	92	RT/PK2.5-2/2 Gray	6011600001	70	-	93
RT/PK2.5 Blue	6011600004	30	-	92	RT/PK2.5-2/2 Blue	6011600006	70	-	93
RT/PK2.5-1/2 Gray	6011600002	30	-	92					
RT/PK2.5-1/2 Blue	6011600005	30	-	92					

## High Current Terminal Blocks

Page 95

Type	Ordering No.	Qty (Box)	Qty (Carton)	Page	Type	Ordering No.	Qty (Box)	Qty (Carton)	Page
RT/SH70 Gray	6010501002	5	25	96	RT/SH150 Gray	6010503002	5	25	97
RT/SH95 Gray	6010502002	5	25	96	RT/SH240 Gray	6010504002	4	20	97

## Transformer Terminal Blocks

Page 99

Type	Ordering No.	Qty (Box)	Qty (Carton)	Page
RT/TC4	6010499002	50	500	99

## Strip Terminal Block Series

Page 101

Type	Ordering No.	Qty (Box)	Qty (Carton)	Page	Type	Ordering No.	Qty (Box)	Qty (Carton)	Page
RT/SS2.5	6010103001	100	1000	102	RT/SS16-5	6010102004	32	320	103
RT/SS6	6010103002	60	600	102	RT/SS16-6	6010102005	30	300	103
RT/SS16-2	6010102001	96	960	103	RT/SS16-8	6010102006	24	240	103
RT/SS16-3	6010102002	32	512	103	RT/SS16-10	6010102007	16	160	103
RT/SS16-4	6010102003	48	480	103	RT/SS16-12	6010102008	8	128	103

## Splicing Terminal Blocks

Page 105

Type	Ordering No.	Qty (Box)	Qty (Carton)	Page	Type	Ordering No.	Qty (Box)	Qty (Carton)	Page
RT/LH4-2	6011301002	50	-	105	RT/LH4-5	6011301005	50	-	105
RT/LH4-3	6011301003	50	-	105					



## End Plates And Partitions

Page <110>

Type	Ordering No.	Qty (Box)	Qty (Carton)	Page	Type	Ordering No.	Qty (Box)	Qty (Carton)	Page
EP-RSTT6	6020201003	50	600	110	EP-RT/SG2.5-10 Gray	6020206003	50	-	110
EP-RSTP6	6020201004	50	900	110	EP-RT/SG2.5-10 Blue	6020206006	50	-	110
EP-RSTN6	6020201006	50	500	110	EP-RT/SG2.5-10E	6020206004	50	-	110
EP-RTP2.5 Blue	6020202001	100	2000	110	EP-RT/SG2.5-4 2L Gray	6020203006	20	-	110
EP-RTP2.5 Yellow	6020202004	100	2000	110	EP-RT/SG2.5-4 2L Blue	6020203021	20	-	110
EP-RTP2.5 Gray	6020202005	100	2000	110	EP-RT/SG2.5-4 2L2E	6020206005	20	400	110
EP-RTP2.5 Red	6020202006	100	2000	110	EP-RT/SF4-2L	6020207001	20	400	110
EP-RTP2.5H-10 Blue	6020202101	50	3000	110	P-RTP2.5 Blue	6020301001	50	2000	110
EP-RTP2.5H-10 Green	6020202102	50	3000	110	P-RTP2.5 Gray	6020301005	50	2000	110
EP-RTP2.5H-10 Yellow	6020202104	50	3000	110	P-RTP2.5H-10 Blue	6020301101	50	1500	110
EP-RTP2.5H-10 Gray	6020202105	50	3000	110	P-RTP2.5H-10 Gray	6020301105	50	1500	110
EP-RTP2.5H-10 Red	6020202106	50	3000	110	P-DRTP4	6020302001	20	300	110
EP-RTP2.5H-10 Brown	6020202107	50	3000	110	SP-2.5-10 Gray	6020304001	100	-	111
EP-RTP2.5H-10 Black	6020202109	50	3000	110	SP-D4	6020304004	100	-	111
EP-DRTP2.5-4 Gray	6020203001	20	500	110	GP Blue	6020305001	20	600	111
EP1-DRTP4	6020203002	20	500	110	GP Gray	6020305005	20	600	111
EP2-DRTP4	6020203003	20	400	110	CB/1	6020802001	20	960	111
EP3-DRTP4	6020203004	20	500	110					
EP-DRTP2.5-4 Blue	6020203005	20	500	110					
EP-RT/SU10-2L	6020203020	10	300	110					
EP-RETN2.5-10	6020206001	50	3000	110					

## End Brackets

Page 112

Type	Ordering No.	Qty (Box)	Qty (Carton)	Page	Type	Ordering No.	Qty (Box)	Qty (Carton)	Page
EB/1	6020101001	50	1000	112	EB/4 Black	6020101006	50	-	112
EB/2	6020101002	50	600	112	EB/4 Gray	6020101006	50	-	112
EB/3 Gray	6020101003	50	1000	112					
EB/3 Black	6020101005	50	1000	112					

## Test Sockets

Page 113

Type	Ordering No.	Qty (Box)	Qty (Carton)	Page	Type	Ordering No.	Qty (Box)	Qty (Carton)	Page
TS/RSTT6 Blue	6020401001	50	5000	113	TS3/2 6/4 (RSTN6)	6020401100	50	5000	113
TS/RSTT6 Yellow	6020401004	50	5000	113	TSS3/26/4	6020401101	50	5000	113
TS/RSTT6 Gray	6020401005	50	5000	113	TS3/6/2.3 2.5-4	6020402001	50	5000	113
TS/RSTT6 Red	6020401006	50	5000	113	TS3/8/4	6020402002	50	5000	113
TS/RSTT6 Black	6020401009	50	5000	113	TS3.5/8/4 16	6020402003	50	5000	113

## Moveable Links

Page 113

Type	Ordering No.	Qty (Box)	Qty (Carton)	Page	Type	Ordering No.	Qty (Box)	Qty (Carton)	Page
ML2N (RSTT6&RST6)	6020602001	50	2400	113	L2 (RSTN6)	6020501001	50	2400	113
ML3N (RSTT6&RST6)	6020602002	50	-	113	L3 (RSTN6)	6020501002	50	2400	113
ML4N (RSTT6&RST6)	6020602003	50	500	113	L4 (RSTN6)	6020501003	50	500	113

## Jumpers

Page 114

Type	Ordering No.	Qty (Box)	Qty (Carton)	Page	Type	Ordering No.	Qty (Box)	Qty (Carton)	Page
CC2-2.5 RTP2.5	6020502001	50	2000	114	CC3-150 (RTP150)	6020502512	50	2000	114
CC3-2.5 RTP2.5	6020502002	50	2000	114	CC2-D4	6020503001	50	2000	114
CC10-2.5 RTP2.5	6020502009	10	500	114	CC3-D4	6020503002	50	500	114
CC2-4 (RTP4)	6020502101	50	2000	114	CC10-D4	6020503009	10	500	114
CC3-4 (RTP4)	6020502102	50	2000	114	BC 2-2.5	6020504001	50	2000	115
CC4-4 (RTP4)	6020502103	50	2000	114	BC 3-2.5	6020504002	50	2000	115
CC10-4 (RTP4)	6020502109	10	500	114	BC 10-2.5	6020504009	10	500	115
CC2-6 (RTP6)	6020502201	50	2000	114	BC 2-4	6020504101	50	2000	115
CC3-6 (RTP6)	6020502202	50	2000	114	BC 3-4	6020504102	50	2000	115
CC10-6 (RTP6)	6020502209	10	500	114	BC 10-4	6020504109	10	500	115
CC2-10 (RTP10)	6020502301	50	2000	114	BC 2-D4	6020504201	50	2000	115
CC3-10 (RTP10)	6020502302	50	2000	114	BC 3-D4	6020504202	50	2000	115
CC10-10 (RTP10)	6020502309	10	300	114	BS 2-2.5	6020505001	100	4800	115
CC2-16 (RTP16)	6020502401	20	800	114	BS 3-2.5	6020505002	100	4800	115
CC3-16 (RTP16)	6020502402	20	800	114	BS 10-2.5	6020505009	10	500	115
CC10-16 (RTP16)	6020502409	10	250	114	BS 2-4	6020505101	100	-	115
CC2-25 (RTP25)	6020502411	20	800	114	BS 3-4	6020505102	100	4800	115
CC3-25 (RTP25)	6020502412	20	800	114	BS 10-4	6020505109	10	500	115
CC10-25 (RTP25)	6020502419	10	250	114	BS 2-6	6020505201	50	2400	115
CC2-35 (RTP35)	6020502431	20	800	114	JEB2-6	6020506001	50	2000	115
CC3-35 (RTP35)	6020502432	20	800	114	JEB3-6	6020506002	50	2000	115
CC10-35 (RTP35)	6020502439	10	250	114	JEB10-6	6020506009	10	500	115
CC2-50 (RTP50)	6020502451	10	240	114					
CC3-50 (RTP50)	6020502452	10	480	114					
CC2-70 (RTP70)	6020502471	10	-	114					
CC3-70 (RTP70)	6020502472	10	240	114					
CC2-95 (RTP95)	6020502491	10	240	114					
CC3-95 (RTP95)	6020502492	10	480	114					
CC2-150 (RTP150)	6020502511	10	100	114					

# Din Rail Socket Outlet

## Din Rail Socket Outlet

Page 117

Type	Ordering No.	Qty (Box)	Qty (Carton)	Page	Type	Ordering No.	Qty (Box)	Qty (Carton)	Page
DSO Gray	6080101001	5	50	118	DSO LD Gray	6080201001	5	50	118
DSO Green	6080101002	5	50	118	DSO LD Green	6080201002	5	50	118
DSO Black	6080101009	5	50	118					

# Switch Disconnectors

## Switch Disconnectors

Page 121

Type	Ordering No.	Qty (Box)	Qty (Carton)	Page	Type	Ordering No.	Qty (Box)	Qty (Carton)	Page
RB/I-1P16A		12	120	122	RFH 10	6050101001	12	120	124
RB/I-1P20A		12	120	122	RFH 102	6050101002	6	60	124
RB/I-1P25A	6125001125	12	120	122	RFH 103	6050101003	4	40	124
RB/I-1P32A	6125001132	12	120	122	RFH 104	6050101004	3	30	124
RB/I-1P40A	6125001140	12	120	122	RFH 10 N	6050102001	6	60	124
RB/I-1P63A	6125001163	12	120	122	RFH 103 N	6050102003	3	30	124
RB/I-3P16A		4	40	122	RFH 10 LD	6050201001	12	120	124
RB/I-3P20A		4	40	122	RFH 102 LD	6050201002	6	60	124
RB/I-3P25A	6125003125	4	40	122	RFH 103 LD	6050201003	4	40	124
RB/I-3P32A	6125003132	4	40	122	RFH 104 LD	6050201004	3	30	124
RB/I-3P40A	6125003140	4	40	122	RFH 10 N LD	6050202001	6	60	124
RB/I-3P63A	6125003163	4	40	122	RFH 103 N LD	6050202003	3	30	124

# Circuit Protection

Type	Ordering No.	Qty (Box)	Qty (Carton)	Page	Type	Ordering No.	Qty (Box)	Qty (Carton)	Page
RB/M-1P B1A-6kA	6120114101	12	120	130	RB/M-2P B20A-10kA	6120125120	6	60	130
RB/M-1P B2A-6kA	6120114102	12	120	130	RB/M-2P B25A-10kA	6120125125	6	60	130
RB/M-1P B4A-6kA	6120114104	12	120	130	RB/M-2P B32A-10kA	6120125132	6	60	130
RB/M-1P B6A-6kA	6120114106	12	120	130	RB/M-2P B40A-10kA	6120125140	6	60	130
RB/M-1P B10A-6kA	6120114110	12	120	130	RB/M-2P B50A-10kA	6120125150	6	60	130
RB/M-1P B16A-6kA	6120114116	12	120	130	RB/M-2P B63A-10kA	6120125163	6	60	130
RB/M-1P B20A-6kA	6120114120	12	120	130	RB/M-3P B1A-6kA	6120134101	4	40	130
RB/M-1P B25A-6kA	6120114125	12	120	130	RB/M-3P B2A-6kA	6120134102	4	40	130
RB/M-1P B32A-6kA	6120114132	12	120	130	RB/M-3P B4A-6kA	6120134104	4	40	130
RB/M-1P B40A-6kA	6120114140	12	120	130	RB/M-3P B6A-6kA	6120134106	4	40	130
RB/M-1P B50A-6kA	6120114150	12	120	130	RB/M-3P B10A-6kA	6120134110	4	40	130
RB/M-1P B63A-6kA	6120114163	12	120	130	RB/M-3P B16A-6kA	6120134116	4	40	130
RB/M-1P B1A-10kA	6120115101	12	120	130	RB/M-3P B20A-6kA	6120134120	4	40	130
RB/M-1P B2A-10kA	6120115102	12	120	130	RB/M-3P B25A-6kA	6120134125	4	40	130
RB/M-1P B4A-10kA	6120115104	12	120	130	RB/M-3P B32A-6kA	6120134132	4	40	130
RB/M-1P B6A-10kA	6120115106	12	120	130	RB/M-3P B40A-6kA	6120134140	4	40	130
RB/M-1P B10A-10kA	6120115110	12	120	130	RB/M-3P B50A-6kA	6120134150	4	40	130
RB/M-1P B16A-10kA	6120115116	12	120	130	RB/M-3P B63A-6kA	6120134163	4	40	130
RB/M-1P B20A-10kA	6120115120	12	120	130	RB/M-3P B1A-10kA	6120135101	4	40	130
RB/M-1P B25A-10kA	6120115125	12	120	130	RB/M-3P B2A-10kA	6120135102	4	40	130
RB/M-1P B32A-10kA	6120115132	12	120	130	RB/M-3P B4A-10kA	6120135104	4	40	130
RB/M-1P B40A-10kA	6120115140	12	120	130	RB/M-3P B6A-10kA	6120135106	4	40	130
RB/M-1P B50A-10kA	6120115150	12	120	130	RB/M-3P B10A-10kA	6120135110	4	40	130
RB/M-1P B63A-10kA	6120115163	12	120	130	RB/M-3P B16A-10kA	6120135116	4	40	130
RB/M-2P B1A-6kA	6120124101	6	60	130	RB/M-3P B20A-10kA	6120135120	4	40	130
RB/M-2P B2A-6kA	6120124102	6	60	130	RB/M-3P B25A-10kA	6120135125	4	40	130
RB/M-2P B4A-6kA	6120124104	6	60	130	RB/M-3P B32A-10kA	6120135132	4	40	130
RB/M-2P B6A-6kA	6120124106	6	60	130	RB/M-3P B40A-10kA	6120135140	4	40	130
RB/M-2P B10A-6kA	6120124110	6	60	130	RB/M-3P B50A-10kA	6120135150	4	40	130
RB/M-2P B16A-6kA	6120124116	6	60	130	RB/M-3P B63A-10kA	6120135163	4	40	130
RB/M-2P B20A-6kA	6120124120	6	60	130	RB/M-4P B1A-6kA	6120144101	3	30	130
RB/M-2P B25A-6kA	6120124125	6	60	130	RB/M-4P B2A-6kA	6120144102	3	30	130
RB/M-2P B32A-6kA	6120124132	6	60	130	RB/M-4P B4A-6kA	6120144104	3	30	130
RB/M-2P B40A-6kA	6120124140	6	60	130	RB/M-4P B6A-6kA	6120144106	3	30	130
RB/M-2P B50A-6kA	6120124150	6	60	130	RB/M-4P B10A-6kA	6120144110	3	30	130
RB/M-2P B63A-6kA	6120124163	6	60	130	RB/M-4P B16A-6kA	6120144116	3	30	130
RB/M-2P B1A-10kA	6120125101	6	60	130	RB/M-4P B20A-6kA	6120144120	3	30	130
RB/M-2P B2A-10kA	6120125102	6	60	130	RB/M-4P B25A-6kA	6120144125	3	30	130
RB/M-2P B4A-10kA	6120125104	6	60	130	RB/M-4P B32A-6kA	6120144132	3	30	130
RB/M-2P B6A-10kA	6120125106	6	60	130	RB/M-4P B40A-6kA	6120144140	3	30	130
RB/M-2P B10A-10kA	6120125110	6	60	130	RB/M-4P B50A-6kA	6120144150	3	30	130
RB/M-2P B16A-10kA	6120125116	6	60	130					



Type	Ordering No.	Qty (Box)	Qty (Carton)	Page
RB/M-4P B63A-6kA	6120144163	3	30	130
RB/M-4P B1A-10kA	6120145101	3	30	130
RB/M-4P B2A-10kA	6120145102	3	30	130
RB/M-4P B4A-10kA	6120145104	3	30	130
RB/M-4P B6A-10kA	6120145106	3	30	130
RB/M-4P B10A-10kA	6120145110	3	30	130
RB/M-4P B16A-10kA	6120145116	3	30	130
RB/M-4P B20A-10kA	6120145120	3	30	130
RB/M-4P B25A-10kA	6120145125	3	30	130
RB/M-4P B32A-10kA	6120145132	3	30	130
RB/M-4P B40A-10kA	6120145140	3	30	130
RB/M-4P B50A-10kA	6120145150	3	30	130
RB/M-4P B63A-10kA	6120145163	3	30	130
RB/M-1P C1A-6kA	6120314101	12	120	130
RB/M-1P C2A-6kA	6120314102	12	120	130
RB/M-1P C4A-6kA	6120314104	12	120	130
RB/M-1P C6A-6kA	6120314106	12	120	130
RB/M-1P C10A-6kA	6120314110	12	120	130
RB/M-1P C16A-6kA	6120314116	12	120	130
RB/M-1P C20A-6kA	6120314120	12	120	130
RB/M-1P C25A-6kA	6120314125	12	120	130
RB/M-1P C32A-6kA	6120314132	12	120	130
RB/M-1P C40A-6kA	6120314140	12	120	130
RB/M-1P C50A-6kA	6120314150	12	120	130
RB/M-1P C63A-6kA	6120314163	12	120	130
RB/M-1P C1A-10kA	6120315101	12	120	130
RB/M-1P C2A-10kA	6120315102	12	120	130
RB/M-1P C4A-10kA	6120315104	12	120	130
RB/M-1P C6A-10kA	6120315106	12	120	130
RB/M-1P C10A-10kA	6120315110	12	120	130
RB/M-1P C16A-10kA	6120315116	12	120	130
RB/M-1P C20A-10kA	6120315120	12	120	130
RB/M-1P C25A-10kA	6120315125	12	120	130
RB/M-1P C32A-10kA	6120315132	12	120	130
RB/M-1P C40A-10kA	6120315140	12	120	130
RB/M-1P C50A-10kA	6120315150	12	120	130
RB/M-1P C63A-10kA	6120315163	12	120	130
RB/M-2P C1A-6kA	6120324101	6	60	130
RB/M-2P C2A-6kA	6120324102	6	60	130
RB/M-2P C4A-6kA	6120324104	6	60	130
RB/M-2P C6A-6kA	6120324106	6	60	130
RB/M-2P C10A-6kA	6120324110	6	60	130
RB/M-2P C16A-6kA	6120324116	6	60	130
RB/M-2P C20A-6kA	6120324120	6	60	130
RB/M-2P C25A-6kA	6120324125	6	60	130
RB/M-2P C32A-6kA	6120324132	6	60	130
RB/M-2P C40A-6kA	6120324140	6	60	130

Type	Ordering No.	Qty (Box)	Qty (Carton)	Page
RB/M-2P C50A-6kA	6120324150	6	60	130
RB/M-2P C63A-6kA	6120324163	6	60	130
RB/M-2P C1A-10kA	6120325101	6	60	130
RB/M-2P C2A-10kA	6120325102	6	60	130
RB/M-2P C4A-10kA	6120325104	6	60	130
RB/M-2P C6A-10kA	6120325106	6	60	130
RB/M-2P C10A-10kA	6120325110	6	60	130
RB/M-2P C16A-10kA	6120325116	6	60	130
RB/M-2P C20A-10kA	6120325120	6	60	130
RB/M-2P C25A-10kA	6120325125	6	60	130
RB/M-2P C32A-10kA	6120325132	6	60	130
RB/M-2P C40A-10kA	6120325140	6	60	130
RB/M-2P C50A-10kA	6120325150	6	60	130
RB/M-2P C63A-10kA	6120325163	6	60	130
RB/M-3P C1A-6kA	6120334101	4	40	130
RB/M-3P C2A-6kA	6120334102	4	40	130
RB/M-3P C4A-6kA	6120334104	4	40	130
RB/M-3P C6A-6kA	6120334106	4	40	130
RB/M-3P C10A-6kA	6120334110	4	40	130
RB/M-3P C16A-6kA	6120334116	4	40	130
RB/M-3P C20A-6kA	6120334120	4	40	130
RB/M-3P C25A-6kA	6120334125	4	40	130
RB/M-3P C32A-6kA	6120334132	4	40	130
RB/M-3P C40A-6kA	6120334140	4	40	130
RB/M-3P C50A-6kA	6120334150	4	40	130
RB/M-3P C63A-6kA	6120334163	4	40	130
RB/M-3P C1A-10kA	6120335101	4	40	130
RB/M-3P C2A-10kA	6120335102	4	40	130
RB/M-3P C4A-10kA	6120335104	4	40	130
RB/M-3P C6A-10kA	6120335106	4	40	130
RB/M-3P C10A-10kA	6120335110	4	40	130
RB/M-3P C16A-10kA	6120335116	4	40	130
RB/M-3P C20A-10kA	6120335120	4	40	130
RB/M-3P C25A-10kA	6120335125	4	40	130
RB/M-3P C32A-10kA	6120335132	4	40	130
RB/M-3P C40A-10kA	6120335140	4	40	130
RB/M-3P C50A-10kA	6120335150	4	40	130
RB/M-3P C63A-10kA	6120335163	4	40	130
RB/M-4P C1A-6kA	6120344101	3	30	130
RB/M-4P C2A-6kA	6120344102	3	30	130
RB/M-4P C4A-6kA	6120344104	3	30	130
RB/M-4P C6A-6kA	6120344106	3	30	130
RB/M-4P C10A-6kA	6120344110	3	30	130
RB/M-4P C16A-6kA	6120344116	3	30	130
RB/M-4P C20A-6kA	6120344120	3	30	130
RB/M-4P C25A-6kA	6120344125	3	30	130
RB/M-4P C32A-6kA	6120344132	3	30	130
RB/M-4P C40A-6kA	6120344140	3	30	130



Type	Ordering No.	Qty (Box)	Qty (Carton)	Page
RB/M-4P C50A-6kA	6120344150	3	30	130
RB/M-4P C63A-6kA	6120344163	3	30	130
RB/M-4P C1A-10kA	6120345101	3	30	130
RB/M-4P C2A-10kA	6120345102	3	30	130
RB/M-4P C4A-10kA	6120345104	3	30	130
RB/M-4P C6A-10kA	6120345106	3	30	130
RB/M-4P C10A-10kA	6120345110	3	30	130
RB/M-4P C16A-10kA	6120345116	3	30	130
RB/M-4P C20A-10kA	6120345120	3	30	130
RB/M-4P C25A-10kA	6120345125	3	30	130
RB/M-4P C32A-10kA	6120345132	3	30	130
RB/M-4P C40A-10kA	6120345140	3	30	130
RB/M-4P C50A-10kA	6120345150	3	30	130
RB/M-4P C63A-10kA	6120345163	3	30	130
RB/MN-1P+N B2A-6KA	6120714102	6	60	130
RB/MN-1P+N B4A-6KA	6120714104	6	60	130
RB/MN-1P+N B6A-6KA	6120714106	6	60	130
RB/MN-1P+N B10A-6KA	6120714110	6	60	130
RB/MN-1P+N B16A-6KA	6120714116	6	60	130
RB/MN-1P+N B20A-6KA	6120714120	6	60	130
RB/MN-1P+N B25A-6KA	6120714125	6	60	130
RB/MN-1P+N B32A-6KA	6120714132	6	60	130
RB/MN-1P+N B40A-6KA	6120714140	6	60	130
RB/MN-1P+N B50A-6KA	6120714150	6	60	130
RB/MN-1P+N B63A-6KA	6120714163	6	60	130
RB/MN-1P+N B2A-10KA	6120715102	6	60	130
RB/MN-1P+N B4A-10KA	6120715104	6	60	130
RB/MN-1P+N B6A-10KA	6120715106	6	60	130
RB/MN-1P+N B10A-10KA	6120715110	6	60	130
RB/MN-1P+N B16A-10KA	6120715116	6	60	130
RB/MN-1P+N B20A-10KA	6120715120	6	60	130
RB/MN-1P+N B25A-10KA	6120715125	6	60	130
RB/MN-1P+N B32A-10KA	6120715132	6	60	130
RB/MN-1P+N B40A-10KA	6120715140	6	60	130
RB/MN-1P+N B50A-10KA	6120715150	6	60	130
RB/MN-1P+N B63A-10KA	6120715163	6	60	130
RB/MN-3P+N B2A-6KA	6120734102	3	30	130
RB/MN-3P+N B4A-6KA	6120734104	3	30	130
RB/MN-3P+N B6A-6KA	6120734106	3	30	130
RB/MN-3P+N B10A-6KA	6120734110	3	30	130
RB/MN-3P+N B16A-6KA	6120734116	3	30	130
RB/MN-3P+N B20A-6KA	6120734120	3	30	130
RB/MN-3P+N B25A-6KA	6120734125	3	30	130
RB/MN-3P+N B32A-6KA	6120734132	3	30	130
RB/MN-3P+N B40A-6KA	6120734140	3	30	130
RB/MN-3P+N B50A-6KA	6120734150	3	30	130
RB/MN-3P+N B63A-6KA	6120734163	3	30	130
RB/MN-3P+N B2A-10KA	6120735102	3	30	130

Type	Ordering No.	Qty (Box)	Qty (Carton)	Page
RB/MN-3P+N B4A-10KA	6120735104	3	30	130
RB/MN-3P+N B6A-10KA	6120735106	3	30	130
RB/MN-3P+N B10A-10KA	6120735110	3	30	130
RB/MN-3P+N B16A-10KA	6120735116	3	30	130
RB/MN-3P+N B20A-10KA	6120735120	3	30	130
RB/MN-3P+N B25A-10KA	6120735125	3	30	130
RB/MN-3P+N B32A-10KA	6120735132	3	30	130
RB/MN-3P+N B40A-10KA	6120735140	3	30	130
RB/MN-3P+N B50A-10KA	6120735150	3	30	130
RB/MN-3P+N B63A-10KA	6120735163	3	30	130
RB/MN-1P+N C2A-6KA	6120814102	6	60	130
RB/MN-1P+N C4A-6KA	6120814104	6	60	130
RB/MN-1P+N C6A-6KA	6120814106	6	60	130
RB/MN-1P+N C10A-6KA	6120814110	6	60	130
RB/MN-1P+N C16A-6KA	6120814116	6	60	130
RB/MN-1P+N C20A-6KA	6120814120	6	60	130
RB/MN-1P+N C25A-6KA	6120814125	6	60	130
RB/MN-1P+N C32A-6KA	6120814132	6	60	130
RB/MN-1P+N C40A-6KA	6120814140	6	60	130
RB/MN-1P+N C50A-6KA	6120814150	6	60	130
RB/MN-1P+N C63A-6KA	6120814163	6	60	130
RB/MN-1P+N C2A-10KA	6120815102	6	60	130
RB/MN-1P+N C4A-10KA	6120815104	6	60	130
RB/MN-1P+N C6A-10KA	6120815106	6	60	130
RB/MN-1P+N C10A-10KA	6120815110	6	60	130
RB/MN-1P+N C16A-10KA	6120815116	6	60	130
RB/MN-1P+N C20A-10KA	6120815120	6	60	130
RB/MN-1P+N C25A-10KA	6120815125	6	60	130
RB/MN-1P+N C32A-10KA	6120815132	6	60	130
RB/MN-1P+N C40A-10KA	6120815140	6	60	130
RB/MN-1P+N C50A-10KA	6120815150	6	60	130
RB/MN-1P+N C63A-10KA	6120815163	6	60	130
RB/MN-3P+N C2A-6KA	6120834102	3	30	130
RB/MN-3P+N C4A-6KA	6120834104	3	30	130
RB/MN-3P+N C6A-6KA	6120834106	3	30	130
RB/MN-3P+N C10A-6KA	6120834110	3	30	130
RB/MN-3P+N C16A-6KA	6120834116	3	30	130
RB/MN-3P+N C20A-6KA	6120834120	3	30	130
RB/MN-3P+N C25A-6KA	6120834125	3	30	130
RB/MN-3P+N C32A-6KA	6120834132	3	30	130
RB/MN-3P+N C40A-6KA	6120834140	3	30	130
RB/MN-3P+N C50A-6KA	6120834150	3	30	130
RB/MN-3P+N C63A-6KA	6120834163	3	30	130
RB/MN-3P+N C2A-10KA	6120835102	3	30	130
RB/MN-3P+N C4A-10KA	6120835104	3	30	130
RB/MN-3P+N C6A-10KA	6120835106	3	30	130
RB/MN-3P+N C10A-10KA	6120835110	3	30	130
RB/MN-3P+N C16A-10KA	6120835116	3	30	130

Type	Ordering No.	Qty (Box)	Qty (Carton)	Page
RB/MN-3P+N C20A-10KA	6120835120	3	30	121
RB/MN-3P+N C25A-10KA	6120835125	3	30	121
RB/MN-3P+N C32A-10KA	6120835132	3	30	121
RB/MN-3P+N C40A-10KA	6120835140	3	30	121
RB/MN-3P+N C50A-10KA	6120835150	3	30	121
RB/MN-3P+N C63A-10KA	6120835163	3	30	121

Type	Ordering No.	Qty (Box)	Qty (Carton)	Page
RB/M-CB	6124001101	12	96	135
RB/M-FB	6124101101	12	96	135
RB/MD-1P B2A-10KA	6120215102	12	120	133
RB/MD-1P B4A-10KA	6120215104	12	120	133
RB/MD-1P B6A-10KA	6120215106	12	120	133
RB/MD-1P B10A-10KA	6120215110	12	120	133
RB/MD-1P B16A-10KA	6120215116	12	120	133
RB/MD-1P B20A-10KA	6120215120	12	120	133
RB/MD-1P B25A-10KA	6120215125	12	120	133
RB/MD-1P B32A-10KA	6120215132	12	120	133
RB/MD-1P B40A-10KA	6120215140	12	120	133
RB/MD-1P B50A-10KA	6120215150	12	120	133
RB/MD-1P B63A-10KA	6120215163	12	120	133
RB/MD-1P C2A-10KA	6120415102	12	120	133
RB/MD-1P C4A-10KA	6120415104	12	120	133
RB/MD-1P C6A-10KA	6120415106	12	120	133
RB/MD-1P C10A-10KA	6120415110	12	120	133
RB/MD-1P C16A-10KA	6120415116	12	120	133
RB/MD-1P C20A-10KA	6120415120	12	120	133
RB/MD-1P C25A-10KA	6120415125	12	120	133
RB/MD-1P C32A-10KA	6120415132	12	120	133
RB/MD-1P C40A-10KA	6120415140	12	120	133
RB/MD-1P C50A-10KA	6120415150	12	120	133
RB/MD-1P C63A-10KA	6120415163	12	120	133
RB/MD-2P B2A-10KA	6120225102	6	60	133
RB/MD-2P B4A-10KA	6120225104	6	60	133
RB/MD-2P B6A-10KA	6120225106	6	60	133
RB/MD-2P B10A-10KA	6120225110	6	60	133
RB/MD-2P B16A-10KA	6120225116	6	60	133
RB/MD-2P B20A-10KA	6120225120	6	60	133
RB/MD-2P B25A-10KA	6120225125	6	60	133
RB/MD-2P B32A-10KA	6120225132	6	60	133
RB/MD-2P B40A-10KA	6120225140	6	60	133
RB/MD-2P B50A-10KA	6120225150	6	60	133
RB/MD-2P B63A-10KA	6120225163	6	60	133
RB/MD-2P C2A-10KA	6120425102	6	60	133
RB/MD-2P C4A-10KA	6120425104	6	60	133
RB/MD-2P C6A-10KA	6120425106	6	60	133
RB/MD-2P C10A-10KA	6120425110	6	60	133

Type	Ordering No.	Qty (Box)	Qty (Carton)	Page
RB/MD-2P C16A-10KA	6120425116	6	60	133
RB/MD-2P C20A-10KA	6120425120	6	60	133
RB/MD-2P C25A-10KA	6120425125	6	60	133
RB/MD-2P C32A-10KA	6120425132	6	60	133
RB/MD-2P C40A-10KA	6120425140	6	60	133
RB/MD-2P C50A-10KA	6120425150	6	60	133
RB/MD-2P C63A-10KA	6120425163	6	60	133

Type	Ordering No.	Qty (Box)	Qty (Carton)	Page
RB/RC-2P 6A 30mA	6123003106	1	48	137
RB/RC-2P 10A 30mA	6123003110	1	48	137
RB/RC-2P 16A 30mA	6123003116	1	48	137
RB/RC-2P 25A 30mA	6123003125	1	48	137
RB/RC-2P 32A 30mA	6123003132	1	48	137
RB/RC-2P 40A 30mA	6123003140	1	48	137
RB/RC-2P 50A 30mA	6123003150	1	48	137
RB/RC-2P 63A 30mA	6123003163	1	48	137
RB/RC-4P 6A 30mA	6123004106	1	24	137
RB/RC-4P 10A 30mA	6123004110	1	24	137
RB/RC-4P 16A 30mA	6123004116	1	24	137
RB/RC-4P 25A 30mA	6123004125	1	24	137
RB/RC-4P 32A 30mA	6123004132	1	24	137
RB/RC-4P 40A 30mA	6123004140	1	24	137
RB/RC-4P 50A 30mA	6123004150	1	24	137
RB/RC-4P 63A 30mA	6123004163	1	24	137
RB/RC-2P 25A 300mA	6123007125	1	48	137
RB/RC-2P 32A 300mA	6123007132	1	48	137

Type	Ordering No.	Qty (Box)	Qty (Carton)	Page
RB/RC-2P 40A 300mA	6123007140	1	48	137
RB/RC-2P 63A 300mA	6123007163	1	48	137
RB/RC-4P 25A 300mA	6123008125	1	24	137
RB/RC-4P 32A 300mA	6123008132	1	24	137
RB/RC-4P 40A 300mA	6123008140	1	24	137
RB/RC-4P 63A 300mA	6123008163	1	24	137

Type	Ordering No.	Qty (Box)	Qty (Carton)	Page
RB/RO-2PC6-6KA-30mA	6123103106	1	48	138
RB/RO-2PC10-6KA-30mA	6123103110	1	48	138
RB/RO-2PC16-6KA-30mA	6123103116	1	48	138
RB/RO-2PC20-6KA-30mA	6123103120	1	48	138
RB/RO-2PC25-6KA-30mA	6123103125	1	48	138
RB/RO-2PC32-6KA-30mA	6123103132	1	48	138
RB/RO-2PC40-6KA-30mA	6123103140	1	48	138
RB/RO-2PC50-6KA-30mA	6123103150	1	48	138
RB/RO-2PC63-6KA-30mA	6123103163	1	48	138

# Mounting Rails and Accessories

## Mounting Rails and Support

Page 141

Type	Ordering No.	Qty (Box)	Qty (Carton)	Page	Type	Ordering No.	Qty (Box)	Qty (Carton)	Page
TH35-7.5/S (2 m)	6090101002	20	40	142	TH35-15/HG (1 m)	6090102007	20	20	143
TH35-15/S (2 m)	6090102002	10	20	142	TH35-15/HG(2 m)	6090102008	10	20	143
TH35-7.5/S (1 m)	6090101003	20	20	142	ARS/M6	6090202001	10	100	144
TH35-15/S (1 m)	6090102003	10	10	142	EC-TH35-7.5	6090203001	100	-	144
TH35-7.5/HG (1 m)	6090101007	20	20	143	EC-TH35-15	6090203002	100	-	144
TH35-7.5/HG(2 m)	6090101008	10	20	143					

# Wiring Duct Systems

## Wiring Duct Systems

Page 147

Type	Ordering No.	Qty (Box)	Qty (Carton)	Page	Type	Ordering No.	Qty (Box)	Qty (Carton)	Page
RWD 25*40 Gray	6110105008	30	60	148	RWD 80*80 Gray	6110116016	8	16	148
RWD 25*60 Gray	6110105012	20	40	148	RWD 80*100 Gray	6110116020	4	8	148
RWD 25*80 Gray	6110105016	10	20	148	RWD 100*60 Gray	6110120012	6	12	148
RWD 40*40 Gray	6110108008	20	40	148	RWD 100*80 Gray	6110120016	4	8	148
RWD 40*60 Gray	6110108012	18	36	148	RWD 100*100 Gray	6110120020	4	8	148
RWD 40*80 Gray	6110108016	14	28	148	RWD 25 Gray Cover	6115050005	20	40	148
RWD 60*40 Gray	6110112008	16	32	148	RWD 40 Gray Cover	6115050008	20	40	148
RWD 60*60 Gray	6110112012	12	24	148	RWD 60 Gray Cover	6115050012	20	40	148
RWD 60*80 Gray	6110112016	8	16	148	RWD 80 Gray Cover	6115050016	10	20	148
RWD 80*60 Gray	6110116012	10	20	148	RWD 100 Gray Cover	6115050020	10	20	148
					RWD 25*40Blue	6110105108	30	60	148
Type	Ordering No.	Qty (Box)	Qty (Carton)	Page	Type	Ordering No.	Qty (Box)	Qty (Carton)	Page
RWD 25*60 Blue	6110105112	20	40	148	HWD 20*12	6110204003	63	126	153
RWD 25*80 Blue	6110105116	10	20	148	HWD 20*20	6110204004	42	84	153
RWD 40*40 Blue	6110108208	20	40	148	HWD 25*20	6110205004	36	72	153
RWD 40*60 Blue	6110108212	18	36	148	HWD 30*30	6110206006	40	80	153
RWD 40*80 Blue	6110108216	14	28	148	HWD 40*40	6110208008	20	40	153
RWD 60*40 Blue	6110112108	16	32	148	HWD 60*40	6110212008	16	32	153
RWD 60*60 Blue	6110112112	12	24	148	HWD 60*60	6110212012	12	24	153
RWD 60*80 Blue	6110112116	8	16	148	HWD 100*60	6110220020	6	12	153
RWD 80*60 Blue	6110116112	10	20	148	HWDS 20*12	6110204001	63	126	154
RWD 80*80 Blue	6110116116	8	16	148	HWDS 20*20	6110204002	42	84	154
RWD 80*100 Blue	6110116120	4	8	148	HWDS 25*20	6110205001	36	72	154
RWD 100*60 Blue	6110120112	6	12	148	HWDS 30*30	6110206001	40	80	154
RWD 100*80 Blue	6110120116	4	8	148					
RWD 100*100 Blue	6110120120	4	8	148	Type	Ordering No.	Qty (Box)	Qty (Carton)	Page
RWD 25 Blue Cover	6115050105	20	40	148	50 OWD	6110310010	30	60	155
RWD 40 Blue Cover	6115050108	20	40	148	70 OWD	6110310014	14	28	155
RWD 60 Blue Cover	6115050112	20	40	148	90 OWD	6110310018	8	16	155
RWD 80 Blue Cover	6115050116	10	20	148					
RWD 100 Blue Cover	6115050120	10	20	148					

# Nylon Cable Ties

## Nylon Cable Ties

Page 159

Type	Ordering No.	Qty (Box)	Qty (Carton)	Page	Type	Ordering No.	Qty (Box)	Qty (Carton)	Page
RC-100/2.5	6100100010	100	15000	159	RC-250/3.6	6100200025	100	5000	159
RC-150/2.5	6100100015	100	10000	159	RC-300/3.6	6100200030	100	5000	159
RC-200/2.5	6100100020	100	7000	159	RC-400/4.8	6100300040	100	2500	159
RC-200/3.6	6100200020	100	6000	159					

# Control Switches

## Control Switches

Page 161

Type	Ordering No.	Qty (Box)	Qty (Carton)	Page	Type	Ordering No.	Qty (Box)	Qty (Carton)	Page
FBC	6070301001	15	180	163	FBC-O Green	6070302101	15	180	164
FBO Black	6070302006	15	180	163	FBC-O White	6070302102	15	180	164
FBO Blue	6070302004	15	180	163	FBC-O Yellow	6070302105	15	180	164
FBO Green	6070302001	15	180	163	FBL-C 110	6070301004	15	180	165
FBO White	6070302009	15	180	163	FBL-C 220	6070301003	15	180	165
FBO Yellow	6070302005	15	180	163	FBL-C 24	6070301006	15	180	165
FBC-C	6070301101	15	180	164	FBL-C 48	6070301005	15	180	165
FBC-O Black	6070302106	15	180	164	FBL-O Blue110	6070302021	15	180	165
FBC-O Blue	6070302104	15	180	164	FBL-O Blue220	6070302020	15	180	165
Type	Ordering No.	Qty (Box)	Qty (Carton)	Page	Type	Ordering No.	Qty (Box)	Qty (Carton)	Page
FBL-O Blue24	6070302023	15	180	165	FBCL-O Blue110	6070302121	15	180	166
FBL-O Blue48	6070302022	15	180	165	FBCL-O Blue220	6070302120	15	180	166
FBL-O Green 110	6070302003	15	180	165	FBCL-O Blue24	6070302123	15	180	166
FBL-O Green 220	6070302002	15	180	165	FBCL-O Blue48	6070302122	15	180	166
FBL-O Green 24	6070302008	15	180	165	FBCL-O Green 110	6070302109	15	180	166
FBL-O Green 48	6070302007	15	180	165	FBCL-O Green 220	6070302108	15	180	166
FBL-O White 24	6070302019	15	180	165	FBCL-O Green 48	6070302110	15	180	166
FBL-O White 48	6070302018	15	180	165	FBCL-O White 24	6070302115	15	180	166
FBL-O White110	6070302017	15	180	165	FBCL-O White 48	6070302114	15	180	166
FBL-O White220	6070302016	15	180	165	FBCL-O White110	6070302113	15	180	166
FBL-O Yellow110	6070302025	15	180	165	FBCL-O White220	6070302112	15	180	166
FBL-O Yellow220	6070302024	15	180	165	FBCL-O yellow110	6070302125	15	180	166
FBL-O Yellow24	6070302027	15	180	165	FBCL-O yellow220	6070302124	15	180	166
FBL-O Yellow48	6070302026	15	180	165	FBCL-O yellow24	6070302127	15	180	166
FBCC-L 110	6070301104	15	180	166	FBCL-O yellow48	6070302126	15	180	166
FBCL-C 220	6070301103	15	180	166					
FBCL-C 24	6070301106	15	180	166					
FBCL-C 48	6070301105	15	180	166					

Type	Ordering No.	Qty (Box)	Qty (Carton)	Page
DPB	6070303001	10	120	167
DPB-C	6070303101	10	120	167
DPBL Red220	6070303003	10	120	168
DPBL110	6070303007	10	120	168
DPBL220	6070303002	10	120	168
DPBL24	6070303009	10	120	168
DPBL48	6070303008	10	120	168
DPBCL 220	6070303102	10	120	168
DPBCL Red220	6070303103	10	120	168

Type	Ordering No.	Qty (Box)	Qty (Carton)	Page
ESTR	6070301002	10	120	169

Type	Ordering No.	Qty (Box)	Qty (Carton)	Page
SEI2	6070303010	12	120	170
SEIC2	6070303110	12	120	171
SEI3	6070303011	12	120	170
SEIC3	6070303111	12	120	171
SEI2-L Green 24	6070303030	12	120	172
SEI2-L Green220	6070303012	12	120	172
SEI2-L Red 24	6070303031	12	120	172
SEI2-L Red220	6070303013	12	120	172
SEI2-L Yellow220	6070303016	12	120	172
SEI2C-L Green220	6070303112	12	120	172
SEI2C-L Red220	6070303113	12	120	172
SEI2C-L Yellow 220	6070303117	12	120	172
SEI3-L Green 24	6070303034	12	120	172
SEI3-L Green220	6070303014	12	120	172
SEI3-L Red 24	6070303035	12	120	172
SEI3-L Red220	6070303015	12	120	172
SEI3-L Yellow220	6070303017	12	120	172
SEI3C-L Green220	6070303114	12	120	173
SEI3C-L Red220	6070303115	12	120	173
SEI3C-L Yellow 220	6070303116	12	120	173

Type	Ordering No.	Qty (Box)	Qty (Carton)	Page
SESC2	6070303020	12	120	175
SESC3	6070303021	12	120	175
SESC3	6070303120	12	120	175
SESC3	6070303121	12	120	175
SES2-L Green 24	6070303028	12	120	176
SES2-L Green220	6070303022	12	120	176
SES2-L Red 24	6070303029	12	120	176
SES2-L Red220	6070303023	12	120	176
SES2-L Yellow220	6070303026	12	120	176
SES2C-L Yellow 220	6070303127	12	120	176
SES3-L Green 24	6070303032	12	120	176

Type	Ordering No.	Qty (Box)	Qty (Carton)	Page
SES3-L Red220	6070303025	12	120	176
SES3-L Yellow220	6070303027	12	120	176
SES3C-L Green220	6070303124	12	120	177
SES3C-L Red220	6070303125	12	120	177
SES3C-L Green220	6070303122	12	120	177
SES3C-L Red220	6070303123	12	120	177
SES3C-L Yellow 220	6070303126	12	120	177

Type	Ordering No.	Qty (Box)	Qty (Carton)	Page
C-FB	6070306008	50	-	178
C-DPB	6070306009	50	-	178
G-ESTR	6070306007	5	-	178

Type	Ordering No.	Qty (Box)	Qty (Carton)	Page
NC Contact	6070402001	50	1500	179
NO Contact	6070401001	50	1500	179

Type	Ordering No.	Qty (Box)	Qty (Carton)	Page
RSC Contact 220v	6070403001	50	1200	179

# Panel Signal Light

## Panel Signal Light

Type	Ordering No.	Qty (Box)	Qty (Carton)	Page
IN 22 Blue 220	6070102401	25	250	179
IN 22 Green 220	6070102402	25	250	179
IN 22 White 220	6070102403	25	250	179
IN 22 Yellow 220	6070102404	25	250	179
IN 22 Red 220	6070102405	25	250	179
IN 22 Blue 220-DC	6070102421	25	250	179
IN 22 Green 220-DC	6070102422	25	250	179

Type	Ordering No.	Qty (Box)	Qty (Carton)	Page
IN 22 White 220-DC	6070102423	25	250	179
IN 22 Yellow 220-DC	6070102424	25	250	179
IN 22 Red 220-DC	6070102425	25	250	179
IN 22 Blue 110	6070103001	25	250	179
IN 22 Green 110	6070103002	25	250	179
IN 22 White 110	6070103003	25	250	179
IN 22 Yellow 110	6070103004	25	250	179

Type	Ordering No.	Qty (Box)	Qty (Carton)	Page
IN 22 Red 110	6070103005	25	250	179
IN 22 Blue 24	6070105001	25	250	179
IN 22 Green 24	6070105002	25	250	179
IN 22 White 24	6070105003	25	250	179
IN 22 Yellow 24	6070105004	25	250	179
IN 22 Red 24	6070105005	25	250	179

Type	Ordering No.	Qty (Box)	Qty (Carton)	Page
RSL 22 Blue 24	6070110001	25	250	179
RSL 22 Green 24	6070110002	25	250	179
RSL 22 White 24	6070110003	25	250	179
RSL 22 Yellow 24	6070110004	25	250	179
RSL 22 Red 24	6070110005	25	250	179
RSL 22 Blue 48	6070120001	25	250	179
RSL 22 Green 48	6070120002	25	250	179
RSL 22 White 48	6070120003	25	250	179
RSL 22 Yellow 48	6070120004	25	250	179
RSL 22 Red 48	6070120005	25	250	179
RSL 22 Blue 110	6070130001	25	250	179
RSL 22 Green 110	6070130002	25	250	179
RSL 22 White 110	6070130003	25	250	179
RSL 22 Yellow 110	6070130004	25	250	179
RSL 22 Red 110	6070130005	25	250	179
RSL 22 Blue 220	6070140001	25	250	179
RSL 22 Green 220	6070140002	25	250	179
RSL 22 White 220	6070140003	25	250	179
RSL 22 Yellow 220	6070140004	25	250	179
RSL 22 Red 220	6070140005	25	250	179

Type	Ordering No.	Qty (Box)	Qty (Carton)	Page
RCI 22 Yellow 24	6070150001	25	250	183
RCI 22 Green 24	6070150002	25	250	183
RCI 22 Blue 24	6070150003	25	250	183
RCI 22 White 24	6070150004	25	250	183
RCI 22 Red 24	6070150005	25	250	183
RCI Blue 48	6070160001	25	250	183
RCI Yellow 48	6070160002	25	250	183
RCI Green 48	6070160003	25	250	183
RCI White 48	6070160004	25	250	183
RCI Red 48	6070160005	25	250	183
RCI Blue 110	6070170001	25	250	183
RCI Yellow 110	6070170002	25	250	183
RCI Green 110	6070170003	25	250	183
RCI White 110	6070170004	25	250	183
RCI Red 110	6070170005	25	250	183
RCI 22 Blue 220-DC	6070180006	25	250	183
RCI 22 Yellow 220-DC	6070180007	25	250	183
RCI 22 Green 220-DC	6070180008	25	250	183
RCI 22 White 220-DC	6070180009	25	250	183

Type	Ordering No.	Qty (Box)	Qty (Carton)	Page
RCI 22 Red 220-DC	6070180010	25	250	183
RCI 22 Blue 220-AC	6070180001	25	250	183
RCI 22 Yellow 220-AC	6070180002	25	250	183
RCI 22 Green 220-AC	6070180003	25	250	183
RCI 22 White 220-AC	6070180004	25	250	183
RCI 22 Red 220-AC	6070180005	25	250	183

Type	Ordering No.	Qty (Box)	Qty (Carton)	Page
BA9S-G 110VAC/DC	6070201003	25	250	184
BA9S-G 220VAC/DC	6070201004	25	250	184
BA9S-R 110VAC/DC	6070202003	25	250	184
BA9S-R 220VAC/DC	6070202004	25	250	184
BA9S-W 24VAC/DC	6070203001	25	250	184
BA9S-W 48VAC/DC	6070203002	25	250	184
BA9S-W 220VAC/DC	6070203004	25	250	184
BA9S/M-W 24VAC/DC	6070204001	25	250	184
BA9S/M-W 48VAC/DC	6070204002	25	250	184
BA9S/M-W 110VAC/DC	6070204003	25	250	184
BA9S/M-W 220VAC/DC	6070204004	25	250	184
BA9S/M-G 24VAC/DC	6070205001	25	250	184
BA9S/M-G 48VAC/DC	6070205002	25	250	184
BA9S/M-G 110VAC/DC	6070205003	25	250	184
BA9S/M-G 220VAC/DC	6070205004	25	250	184
BA9S/M-R 24VAC/DC	6070206001	25	250	184
BA9S/M-R 48VAC/DC	6070206002	25	250	184
BA9S/M-R 110VAC/DC	6070206003	25	250	184
BA9S/M-R 220VAC/DC	6070206004	25	250	184

# Crimping Terminal

## ■ Ferrule

Page 187

Type	Ordering No.	Qty (Box)	Qty (Carton)	Page	Type	Ordering No.	Qty (Box)	Qty (Carton)	Page
ES 0,50/10 E	8017435220	100	-	188	IES 10,0/12 E Brown	8017435075	100	-	189
ES 0,75/10 E	8017435230	100	-	188	IES 16,0/12 E Beige	8017435085	100	-	189
ES 1,0/10 E	8017435240	100	-	188	IES 25,0/16 E Black	8017435095	100	-	189
ES 1,5/10 E	8017435250	100	-	188	IES 35,0/16 E Red	8017435105	100	-	189
ES 1,5/8 E	8017435258	100	-	188	IES 50,0/20 E Blue	8017435115	100	-	189
ES 2,5/12 E	8017435260	100	-	188	IES 2x0,50/8 E White	8017435405	100	-	190
ES 2,5/8 E	8017435268	100	-	188	IES 2x0,75/8 E Blue	8017435415	100	-	190
ES 4,0/12 E	8017435270	100	-	188	IES 2x1,0/8 E Red	8017435425	100	-	190
ES 6,0/12 E	8017435280	100	-	188	IES 2x1,5/8 E Black	8017435435	100	-	190
ES 10,0/15 E	8017435290	100	-	188	IES 2x2,5/10 E Gray	8017435445	100	-	190
ES 16,0/15 E	8017435300	100	-	188	IES 2x4,0/12 E Orange	8017435455	100	-	190
ES 25,0/16 E	8017435310	100	-	188	IES 2x6,0/14 E Green	8017435465	100	-	190
ES 35,0/16 E	8017435320	100	-	188	IES 2x10,0/14 E Brown	8017435475	100	-	190
ES 50,0/20 E	8017435330	100	-	188	IES 2x16,0/14 E Beige	8017435485	100	-	190
IES 0,50/8 E White	8017435005	100	-	189					
IES 0,75/8 E Blue	8017435015	100	-	189					
IES 1,0/8 E Red	8017435025	100	-	189					
IES 1,5/8 E Black	8017435035	100	-	189					
IES 2,5/8 E Gray	8017435045	100	-	189					
IES 4,0/9 E Orange	8017435155	100	-	189					
IES 6,0/12 E Green	8017435065	100	-	189					

## ■ Connector

Page 177

Type	Ordering No.	Qty (Box)	Qty (Carton)	Page	Type	Ordering No.	Qty (Box)	Qty (Carton)	Page
BMT 1040 E	8018436700	100	-	191	FFT 2488 E	8018436120	100	-	194
BMT 2050 E	8018436710	100	-	191	FFT 2638 E	8018436130	100	-	194
BMT 5050 E	8018436720	100	-	191	FFT 5638 E	8018436140	100	-	194
BFT 1040 E	8018436600	100	-	192	IFFT 1288 E	8018436300	100	-	195
BFT 2050 E	8018436610	100	-	192	IFFT 1488 E	8018436310	100	-	195
BFT 5050 E	8018436620	100	-	192	IFFT 1638 E	8018436320	100	-	195
FMT 1638 E	8018436170	100	-	193	IFFT 2288 E	8018436325	100	-	195
FMT 2488 E	8018436180	100	-	193	IFFT 2488 E	8018436330	100	-	195
FMT 2638 E	8018436190	100	-	193	IFFT 2638 E	8018436340	100	-	195
FFT 1638 E	8018436110	100	-	194	IFFT 5638 E	8018436350	100	-	195

**Lug**

Type	Ordering No.	Qty (Box)	Qty (Carton)	Page	Type	Ordering No.	Qty (Box)	Qty (Carton)	Page
IBT 251 E	8018436500	100	-	196	IFT 401 E	8018435720	100	-	198
IBT 252 E	8018436510	100	-	196	IFT 501 E	8018435730	100	-	198
IBT 256 E	8018436520	100	-	196	IFT 601 E	8018435740	100	-	198
IRT 301 E	8018435500	100	-	197	IFT 352 E	8018435750	100	-	198
IRT 351 E	8018435510	100	-	197	IFT 402 E	8018435760	100	-	198
IRT 401 E	8018435520	100	-	197	IFT 502 E	8018435770	100	-	198
IRT 501 E	8018435530	100	-	197	IFT 602 E	8018435780	100	-	198
IRT 601 E	8018435540	100	-	197	IFT 406 E	8018435790	100	-	198
IRT 801 E	8018435550	100	-	197	IFT 506 E	8018435800	100	-	198
IRT 302 E	8018435560	100	-	197	IFT 606 E	8018435810	100	-	198
IRT 402 E	8018435570	100	-	197	IFT 806 E	8018435820	100	-	198
IRT 502 E	8018435580	100	-	197					
IRT 602 E	8018435590	100	-	197					
IRT 802 E	8018435600	100	-	197					
IRT 1002 E	8018435610	100	-	197					
IRT 406 E	8018435620	100	-	197					
IRT 506 E	8018435630	100	-	197					
IRT 606 E	8018435640	100	-	197					
IRT 806 E	8018435650	100	-	197					
IRT 1006 E	8018435660	100	-	197					
IRT 1206 E	8018435670	100	-	197					
IRT 510 E	8018435680	100	-	197					
IRT 610 E	8018435690	100	-	197					
IFT 301 E	8018435700	100	-	198					

**Kit**

Type	Ordering No.	Qty (Box)	Qty (Carton)	Page	Type	Ordering No.	Qty (Box)	Qty (Carton)	Page
Circular Assortment 1	8017455480	-	-	199	Rectangular Assortment 1	8018536721	-	-	200
Circular Assortment 2	8017455481	-	-	199	Rectangular Assortment 2	8018536722	-	-	200
Circular Assortment 3	8017455482	-	-	199					

# Marking Solution

**Marking Solution**

Type	Ordering No.	Qty (Box)	Qty (Carton)	Page	Type	Ordering No.	Qty (Box)	Qty (Carton)	Page
CM 1	8021334009	100	-	204	TYPET 17x50	8022130310	50	-	204
CM 2	8021334019	100	-	204	TYPET 17x30	8022130300	100	-	204
TBET 40x30	8022130330	60	-	204	ASE60	8022130350	1	-	205
TBET 50x30	8022130340	60	-	204	TBSL 22x20	8020384009	1	-	205
TYPET 17x75	8022130320	25	-	204					

# Relay Modules

## Relay Modules

Page 193

Type	Ordering No.	Qty (Box)	Qty (Carton)	Page	Type	Ordering No.	Qty (Box)	Qty (Carton)	Page
TRB LT-2C-10A-12 V DC	8036322000	20	-	210	TRB LT-4C-5A-115 V AC	8036324560	20	-	212
TRB LT-2C-10A-24 V DC	8036322010	20	-	210	TRB LT-4C-5A-230 V AC	8036324570	20	-	212
TRB LT-2C-10A-48 V DC	8036322020	20	-	210	TS-V TRB 2C	8036024000	10	-	215
TRB LT-2C-10A-110 V DC	8036322030	20	-	210	TS-V TRB 4C	8036024002	10	-	215
TRB LT-2C-10A-220 V DC	8036322032	20	-	210	CP-TRB	8036330001	10	-	202
TRB LT-2C-10A-24 V AC	8036322040	20	-	210	RCM (110-230 VAC)	8036330042	10	-	216
TRB LT-2C-10A-48 V AC	8036322050	20	-	210	DM (6-230 VDC)	8036330011	10	-	216
TRB LT-2C-10A-115 V AC	8036322060	20	-	210	PINT-R1 24 V	8131241525	20	-	219
TRB LT-2C-10A-230 V AC	8036322070	20	-	210	PINT-R1 60 V	8131241527	20	-	219
TRB LT-4C-5A-12 V DC	8036324500	20	-	212	PINT-1C 24 V DC-6A	8031241500	20	-	221
TRB LT-4C-5A-24 V DC	8036324510	20	-	212	PINT-1C 220-240 V DC-6A	8031241513	20	-	221
TRB LT-4C-5A-48 V DC	8036324520	20	-	212	PINT Adapter	8031241533	1	-	222
TRB LT-4C-5A-110 V DC	8036324530	20	-	212	JP-PINT-20-Blue	8036331000	5	-	223
TRB LT-4C-5A-220 V DC	8036324532	20	-	212	JP-PINT-20-Black	8036331001	5	-	223
TRB LT-4C-5A-24 V AC	8036324540	20	-	212	JP-PINT-20-Red	8036331002	5	-	223
TRB LT-4C-5A-48 V AC	8036324550	20	-	212					

# Distribution Terminal Blocks

## Distribution Terminal Blocks

Page 225

Type	Ordering No.	Qty (Box)	Qty (Carton)	Page	Type	Ordering No.	Qty (Box)	Qty (Carton)	Page
SDB 80A	8037000100	1	120	226	TDB 2x7-125A	8037000230	1	138	231
SDB 125A	8037000110	1	120	226	TDB 2x11-125A	8037000231	1	84	231
SDB 160A	8037000120	1	120	227	TDB 2x15-125A	8037000232	1	72	232
SDB 250A	8037000130	1	60	227	FDB 4x8-80A	8037000310	1	74	233
SDB 400A	8037000140	1	60	228	FDB 4x18-80A	8037000312	1	40	233
SDB 500A	8037000150	1	60	228	FDB 4x7-100A	8037000320	1	74	234
TDB 2x8-80A	8037000210	1	138	229	FDB 4x11-100A	8037000321	1	50	234
TDB 2x18-80A	8037000211	1	72	229	FDB 4x7-125A	8037000330	1	74	235
TDB 2x7-100A	8037000220	1	138	230	FDB 4x11-125A	8037000331	1	50	235
TDB 2x11-100A	8037000221	1	84	230	FDB 4x15-125A	8037000332	1	40	236